

**DISCLAIMER:**

This is a preliminary business case, used to inform decision-making by the Murray-Darling Basin Ministerial Council and Basin Officials' Committee on sustainable diversion limit adjustment mechanism projects.

The document represents the *Business case for Improved flow management works at the Murrumbidgee Rivers – Yanco Creek offtake* at August 2015.

The NSW Department of Industry is currently developing project summary documents that will summarise project details, and will be progressively published on the [Department of Industry website](#).

Detailed costings and personal information has been redacted from the original business case to protect privacy and future tenders that will be undertaken to deliver these projects.



Department of  
Primary Industries  
Water

SDL ADJUSTMENT BUSINESS CASE

## Improved flow management works at the Murrumbidgee Rivers – Yanco Creek offtake



## Version Control

Version	Prepared	Date
1.	[REDACTED]	29.06.2015
2.	[REDACTED]	30.06.2015
3.	[REDACTED]	02.08.2015
4.	[REDACTED]	10.08.2015

### WaterNSW primary contact details

[REDACTED]  
[REDACTED]  
[REDACTED]

Cover Image: Yanco regulator on the Murrumbidgee River

## Executive Summary

### Introduction

The 'Improved flow management works at the Murrumbidgee Rivers – Yanco Creek offtake' Project (the Project) will achieve SDL Adjustment through improved delivery of environmental flows to the Mid Murrumbidgee wetlands. Complementary works will also improve fish passage for large bodied fish along the Murrumbidgee River and regulate flows to the Yanco Creek to deliver improved flow regimes.

### Contribution to SDL adjustments

Yanco offtake was constructed to develop and expand agricultural production in the Yanco system. The offtake joins Yanco Creek to the Murrumbidgee River and provides flow to the creek system, even when flow in the Murrumbidgee River is quite low.

The current infrastructure arrangement includes an existing gated regulator on the Murrumbidgee River (Yanco Regulator) and an existing (older) fixed crest weir (Yanco Weir). The Yanco Regulator is designed to divert flows into Yanco Creek, in combination with the water level created by Yanco Weir which determines the flow that Yanco Creek receives. Under current operation approximately 10% of flow from the Murrumbidgee River is diverted into the Yanco Creek system through the Yanco offtake.

The proposed works and measures have been designed to increase the proportion of higher flows that reach the mid- Murrumbidgee and lower Murrumbidgee wetlands downstream of Yanco Weir. The proposed structures also allow targeted diversion of water into the Yanco system to reinstate a more appropriate regime of freshes, bank-full and overbank flows recommended by the Yanco Creek System environmental flows study. The volume of water required to be reinstated in the Yanco system is smaller than the flows added to the Murrumbidgee by the proposed structures, leading to an improved environmental outcome along the Murrumbidgee River.

The proposed works include:

- **Yanco Creek Regulator and Fishway** – a new regulator to be installed in Yanco Creek to allow regulation of flows between the Murrumbidgee River and Yanco Creek. Operation of the regulator during targeted environmental watering events for the Mid Murrumbidgee improves watering efficiency of the environmental asset.
- **Increased weir pool level at Yanco weir** - The weir pool will be raised at the Yanco weir so that environmental flows can be provided to Yanco Creek without having to provide large flows downstream in the Murrumbidgee River.
- **New Murrumbidgee Regulator at Yanco Weir** - An investigation of the structural and mechanical capacity of the existing gated regulator at Yanco weir indicates that it is not suitable for upgrading for the increased water level associated with the new weir pool design level. It is proposed to install a new regulator in the meander reach that currently has the older Yanco fixed crest weir.
- **Fishway at new Murrumbidgee Regulator** - The project will provide for both upstream and downstream fish passage in the Murrumbidgee River at Yanco weir. The existing

structures are significant barriers to fish migration in both directions, except during high flow events.

### **Anticipated environmental benefits**

The Mid Murrumbidgee wetlands comprise relatively intact flood-dependent vegetation communities that provide crucial habitat for numerous conservationally significant fauna species, and are targeted for inundation through several of the Specific Flow Indicators set by the MDBA. The wetlands are an important area for waterbirds including breeding of colonial nesting waterbirds and contain a range of riparian and wetland vegetation communities that are critical to several fish species in the Murrumbidgee, including Murray Cod.

Anticipated environmental benefits associated with the project stem from the ability to achieve targeted watering events (specific flow indicators) more frequently. The project provides a significant improvement in the achievement of all specific flow indicator events for the Mid Murrumbidgee Wetlands, along with improvements to the Lower Murrumbidgee Floodplain Wetlands and Murrumbidgee River indicators. For the mid Murrumbidgee wetlands the project not only increases the frequency of watering, but also provides an increased and improved extent of inundation when watering does occur.

Additionally, the Murrumbidgee River and Yanco Creek support a valuable native fish community. The current Yanco weir is a barrier to fish through a non-functional submerged fishway that limits fish passage through the structure for flows less than ~25,000 ML/d. The proposed new infrastructure will improve fish passage around the structure.

### **Synergies with other projects**

The proposed project is one of three related initiatives being progressed for the Murrumbidgee River. This project is closely aligned and integrated with:

- Computer Aided River Management (CARM) along the Murrumbidgee River.
- Modernising supply systems for effluent creeks – Murrumbidgee River.

Additionally, this supply measure complements the:

- constraints management strategy by providing the ability to control high flows down the creek and avoid overbank events in upper Yanco Creek at undesirable times - the Yanco Creek regulator is the critical component of achieving control of high flows and mitigating flooding impacts, and
- the Nimmie-Caira infrastructure modifications proposal, and the Murray and Murrumbidgee National Parks SDL Adjustment proposal by increasing the delivery of environmental flows to this area, and helping to offset any downstream effects of any increased environmental water use in Lowbidgee..

### **Consultation and support**

Targeted discussion with interest groups regarding the project identified a number of potential issues for consideration and response in this business case. The majority of issues raised were addressed within the design process and the development of proposed operating rules for the new structures.

Ongoing engagement with interest groups in future project stages is an essential component to the delivery program for the project. Community involvement in the development and formalisation of operational rules for Yanco Creek offtake may assist to alleviate residual concerns regarding provision of flows in Yanco Creek system during times of water scarcity.

### **Mitigation of third party impacts**

Proposed operating rules for the structures documented in the business case were developed to address potential risks to the supply of water to Yanco Creek system water users and environment, and the increase in backwater created by the proposed weir. Formalisation of the operating rules of both structures on the Murrumbidgee River and Yanco Creek is a significant piece of work that will be led by the NSW government in collaboration with water users and the community.

The only risk that is not planned to be mitigated is the impact on movement of small bodied fish upstream of weir structures as it is not possible to provide satisfactory fish passage that is suitable for all types of fish. On the Murrumbidgee River there is currently no effective fish passage through a number of key flow regulation structures along the Murrumbidgee River for small bodied fish, and the proposed changes do not alter that status-quo. However, although it is a low risk, there is a negative effect on the common and abundant small bodied fish in the Yanco Creek, as the new regulator would limit their ability to move upstream to the Murrumbidgee River. Despite migration not being required as an obligatory part of their lifecycle, summer flows will trigger small bodied fish to travel upstream and there would likely be greater mortality rates at the weir barrier.

### **Costs and funding**

The works proposed for the supply measure is estimated to involve a total investment of \$50.5 million. This costing comprises █████ construction costs and a further █████ in project management costs.

## Table of contents

1	Introduction .....	1
1.1	Improving flow management in the Murrumbidgee and Yanco systems .....	1
1.2	Murrumbidgee business case package .....	1
1.3	SDL adjustments through works and measures .....	2
1.4	Terms of reference.....	3
1.5	Background to the proposal .....	3
1.6	Proposed benefit of works.....	4
1.7	Eligibility.....	4
1.8	Proponent and proposed implementing entity .....	5
2	Project details .....	6
2.1	Locality .....	6
2.2	Proposed works package and adjustment.....	7
2.3	Interaction with other initiatives .....	7
2.4	Current hydrology .....	9
2.5	Ecological Assets.....	12
2.6	Environmental values.....	22
3	Proposed works and measures.....	32
3.1	Current structures at Yanco offtake.....	32
3.2	Proposed arrangement .....	36
3.3	Proposed infrastructure rules and hydrology.....	55
3.4	Costs .....	57
4	Anticipated outcomes.....	59
4.1	Anticipated ecological outcomes .....	59
4.2	Achievement of objectives and targets.....	62
4.3	Fish passage .....	65
5	Potential adverse impacts .....	68

5.1	Risk assessment framework .....	68
5.2	Risk categories overview .....	69
5.3	Impact on diversions .....	76
5.4	Altering hydrology in the Yanco creek .....	77
5.5	Creation of backwater .....	79
5.6	Blocking fish passage between the Murrumbidgee and Yanco creek .....	81
5.7	Resolving operational rules .....	81
5.8	Risk assessment conclusion .....	82
6	Technical feasibility and fitness for purpose .....	84
6.1	Options assessment .....	84
6.2	Ecological considerations associated with works site .....	85
6.3	Heritage considerations associated with works site .....	89
7	Stakeholders .....	91
7.1	Overview .....	91
7.2	Stakeholder map .....	92
1.1	Feedback on consultation outcomes .....	93
7.3	Further consultation plans .....	94
8	Project delivery plan .....	96
8.1	Operation date for proposal .....	96
8.2	Legal and regulatory requirements .....	96
8.3	Heritage constraints .....	101
8.4	Legislative and policy amendments and inter-jurisdictional agreements .....	103
8.5	Governance and project management .....	103
8.6	Monitoring and evaluation .....	103
9	References .....	1
	Appendix 1. Summary of response to the Phase 2 Assessment Guidelines .....	4
	Appendix 2 Yanco Creek environmental flow achievement under proposed conditions .....	6
	Reach 1 results .....	6



Reach 2 results .....	8
Reach 3 results .....	10
Reach 4a results.....	12
Reach 5 results .....	14
Reach 6 results .....	16
Appendix 3. Preliminary ecological constraints assessment Desktop heritage constraints assessment.....	19
Appendix 4. Fish ecology report.....	20
Murrumbidgee River and Yanco Creek fish community .....	20
Broad fish movement patterns.....	20
Movement to-and-from Yanco Creek.....	20
Ecological Priorities .....	22
Priority Fish Passage Objectives .....	22
Risks 22	
References.....	4
Appendix 5. Key issues workshop minutes .....	5

## Tables

Table 1. Environmental objectives and targets: Mid Murrumbidgee River Wetlands (MDBA 2012)	16
Table 2. Flow recommendations for riparian and wetland vegetation in the Yanco Creek system	20
Table 3. The fish community which occurs in the Murrumbidgee River. H=high flow, M=medium flow, L=low flow. *Unlikely indicates fish species that once occurred in the Murrumbidgee catchment but have not been recorded in the last 20-30 years. # indicates a species with conservation significance. Scale of movement is micro (<100 metres), meso (100s to 10s km) macro (100s km).	24
Table 4. The timing of fish migrations in the Yanco Weir area of the mid Murrumbidgee River system.	26
Table 5 Waterbird Counts across Mid Murrumbidgee wetlands.	29
Table 6. Yanco offtake construction cost estimate	57
Table 7. Equivalent flows in the Murrumbidgee River at Narrandera to achieve the equivalent inundation of Mid Murrumbidgee Floodplain Wetlands as the benchmark for each SFI. Source: WaterNSW	63
Table 8. Frequency of years –that SFI events in the mid and lower Murrumbidgee region are achieved under benchmark and proposed conditions.	64
Table 9. ISO Risk Matrix	68
Table 10. Definitions of the levels of risk	68
Table 11. Overview of risk areas	69
Table 12. Overview of risk assessment and mitigation for project development and construction risks	70
Table 13. Diversions in the Murrumbidgee system under the benchmark and proposal (GL/year)	77
Table 14. End of system flows under the benchmark and proposal (GL/year)	77
Table 15. High level summary of the influence of the proposal on environmental flow performance in Yanco Creek.	79
Table 16. Likely interest groups to be involved in the development of operational rules	82
Table 17. Threatened fauna in the site area	88
Table 18. Map of agencies, groups and individual stakeholders with an interest in the SDL adjustment proposal, including their interface with proposal and areas of concern.	92
Table 19. Consultation strategy for the implementation phase	95

Table 20. Summary of possible Commonwealth and State approvals .....	97
Table 21. Summary of Matters of National Environmental Significance relevant to the project.	98
Table 22. Concordance - SDLAAC Phase 2 Assessment Guidelines and Business Case.....	4
Table 23. <i>Reach 1 – Achievement of baseflow recommendations under benchmark and proposed conditions</i> .....	6
Table 24. Reach 1 – Percentage of years in the flow record that the recommended number of events is achieved.....	7
Table 25. Reach 1 – Percentage of target events achieved that persist for the recommended duration.....	7
Table 26. Reach 2 – Achievement of baseflow recommendations under benchmark and proposed conditions.....	8
Table 27. Reach 2 – Percentage of years in the flow record that the recommended number of events is achieved.....	9
Table 28. Reach 2 – Percentage of target events achieved that persist for the recommended duration.....	10
Table 29. Reach 3 – Achievement of baseflow recommendations under benchmark and proposed conditions.....	10
Table 30. Reach 3 – Percentage of years in the flow record that the recommended number of events is achieved.....	11
Table 31. Reach 3 – Percentage of target events achieved that persist for the recommended duration.....	11
Table 32. Reach 4a – Achievement of baseflow recommendations under benchmark and proposed conditions.....	12
Table 33. Reach 4a – Percentage of years in the flow record that the recommended number of events is achieved.....	13
Table 34. Reach 4a – Percentage of target events achieved that persist for the recommended duration.....	14
Table 35. Reach 5 – Achievement of baseflow recommendations under benchmark and proposed conditions.....	14
Table 36. Reach 5 – Percentage of years in the flow record that the recommended number of events is achieved.....	16
Table 37. Reach 5 – Percentage of target events achieved that persist for the recommended duration.....	16
Table 38. Reach 6 – Achievement of baseflow recommendations under benchmark and proposed conditions.....	17

Table 39. Reach 6 – Percentage of years in the flow record that the recommended number of events is achieved..... 18

Table 40. Reach 6 – Percentage of target events achieved that persist for the recommended duration..... 18

## Figures

Figure 1. Murrumbidgee catchment - Yanco Creek system circled in red ..... 6

Figure 2. Location of Yanco offtake ..... 6

Figure 3. Comparison of without-development and actual flows at Wagga Wagga, 1913–96: Mid-Murrumbidgee River Wetlands. (Source: reproduced from Whitten and Bennett 2000, MDBA 2012)..... 10

Figure 4. Flow rates of the Murrumbidgee River at Narrandera from 1990 to April 2013, showing one of the critical thresholds for inundation of mid-Murrumbidgee wetlands as specified in the Assessment of environmental water requirements for the proposed Basin Plan: Mid-Murrumbidgee River Wetlands (MDBA 2012d) (<http://www.mdba.gov.au/what-we-do/environmental-water/environmental-watering-priorities/priorities-13-14/mid-murrumbidgee>) 11

Figure 5. Mid Murrumbidgee wetlands ..... 13

Figure 6. Wetlands mapped in the Yanco Creek system through two previous projects – Investigation into potential water savings from the Yanco Creek system (offtake to Yanco Bridge) wetlands (Webster 2007) (referred to as Stage 1), and the follow-on Stage 2 study (GIS data only, Webster unpublished) ..... 18

Figure 7. Location of structures within the site..... 32

Figure 8. Current relationship between flow in the Murrumbidgee River downstream of Yanco Weir (x-axis) and the flow to Yanco Creek at the Yanco offtake (y-axis)..... 33

Figure 9. Summary of details of the existing Yanco Regulator structure ..... 34

Figure 10. Existing (older) fixed crest weir ..... 35

Figure 11. Arrangement of proposed infrastructure works at the Yanco site..... 37

Figure 12. Proposed site for new regulator ..... 39

Figure 13. Concept design details for the proposed Yanco Creek regulator ..... 40

Figure 14. Yanco Creek regulator capacities – Fully Open..... 41

Figure 15. Yanco Creek Regulator showing water levels and velocity ..... 42

Figure 16. Water surface profiles for Yanco Creek ..... 43

Figure 17. Conceptual cross-section of temporary diversion channel design..... 43

Figure 18. Location of new regulator in Murrumbidgee River at Yanco.....	45
Figure 19. Schematic showing new Murrumbidgee Regulator at Yanco Weir, including approach ramps and access road.....	46
Figure 20. New four-gate regulator – Discharge capacity .....	47
Figure 21. Head loss through new regulator, with all gates fully open .....	48
Figure 22. Water depths upstream of Yanco offtake under existing conditions (source: Hydraulic Modelling and Inundation Mapping for the Murrumbidgee River and Tumut, Beavers, Old Man and Yanco watercourses, WaterNSW) .....	49
Figure 23. Water depths upstream of Yanco offtake under proposed conditions, weir pool level of 138.0m AHD (source: Hydraulic Modelling and Inundation Mapping for the Murrumbidgee River and Tumut, Beavers, Old Man and Yanco watercourses, State Water Corporation) .....	50
Figure 24. Water depths upstream of Yanco offtake under proposed conditions, weir pool level of 139.68 m AHD (source: Hydraulic Modelling and Inundation Mapping for the Murrumbidgee River and Tumut, Beavers, Old Man and Yanco watercourses, WaterNSW).....	51
Figure 25. Flow distribution (Sep – Mar) at gauge 410 036 on Murrumbidgee River downstream of Yanco Weir .....	52
Figure 26. Cross-section downstream of existing Yanco Weir .....	52
Figure 27. Schematic of two-step fishway .....	53
Figure 28. Concept arrangement for vertical slot fishway at the new Murrumbidgee River regulator.....	54
Figure 29. Proposed upgrade to arrangement at Yanco Regulator.....	55
Figure 30. Relationship between area inundated and flow in Murrumbidgee under benchmark and proposal .....	65
Figure 31. Level duration curve, showing percentage of time the weir is expected to be held above a given water level.....	80
Figure 32. Cost comparison of options investigated .....	85
Figure 33. Proposed implementation timeframe for the project.....	96
Figure 34. Approvals pathway under Part 5 of the EP&A Act 1979 (GHD 2014b) .....	101
Figure 35. Reach 1 – Number of events achieved each year .....	7
Figure 36. Reach 1 – Total duration of flows above recommended rate each year.....	7
Figure 37. Reach 2 – Number of events achieved each year .....	9
Figure 38. Reach 2 – Total duration of flows above recommended rate each year.....	9
Figure 39. Reach 3 – Number of events achieved each year .....	11

Figure 40. Reach 3 – Total duration of flows above recommended rate each year.....	11
Figure 41. Reach 4a – Number of events achieved each year .....	13
Figure 42. Reach 4a – Total duration of flows above recommended rate each year.....	14
Figure 43. Reach 5 – Number of events achieved each year .....	15
Figure 44. Reach 5 – Total duration of flows above recommended rate each year.....	16
Figure 45. Reach 6 – Number of events achieved each year .....	17
Figure 46. Reach 6 – Total duration of flows above recommended rate each year.....	18

## 1 Introduction

### 1.1 Improving flow management in the Murrumbidgee and Yanco systems

This business case proposes investment in works to allow more efficient watering of the Mid Murrumbidgee wetlands, resulting in SDL Adjustment. The proposed works and measures have been designed to increase the proportion of higher flows that reach the mid- Murrumbidgee and lower Murrumbidgee wetlands downstream of Yanco Weir.

The proposed structures also allow targeted diversion of water into the Yanco system to reinstate a more appropriate regime of freshes, bank-full and overbank flows recommended by the Yanco Creek System environmental flows study (Alluvium 2013). The volume of water required to be reinstated in the Yanco system are smaller than the flows added to the Murrumbidgee by the proposed structures, leading to an improved environmental outcome along the Murrumbidgee River.

### 1.2 Murrumbidgee business case package

This business case is one of three related initiatives being progressed for the Murrumbidgee River system. The three business cases are closely integrated and comprise:

- Computer Aided River Management (CARM) along the Murrumbidgee River.
- Yanco Creek offtake regulator at the Murrumbidgee River - to improve flow management (this business case).
- Modernising supply systems for effluent creeks – Murrumbidgee River.

All three initiatives will deliver equivalent environmental outcomes as in the Basin Plan but require less water to do so. Each element will generate an SDL offset.

**CARM:** the CARM project will provide greater control and modelling of flows through the river and creek systems. That will allow environmental flows and consumptive demands to be met with greater precision so reducing operational surpluses from the need to supply extra water to ensure that requirements are met.

**Yanco Creek Regulator:** the Yanco Creek offtake regulator will enable greater control of inflows to the Yanco Creek system from the Murrumbidgee River. That will allow greater precision in the matching of supply and demand in the Yanco Creek system to meet environmental and consumptive demands. It will also allow high flows to be shepherded along the Murrumbidgee to achieve targeted environmental watering outcomes. Both outcomes will ensure that equivalent environmental benefits are achieved but with less water.

**Modernising the Effluent Creek supply systems** will reduce water losses in distribution while retaining environmental values. The water saving will be added to the held environmental water in the Murrumbidgee valley. This held water can then be targeted to meet specific environmental flow requirements where required. Reduction of irrigation supplies in the creek system will also permit creation of preferred flow regimes.

### 1.3 SDL adjustments through works and measures

The Murray-Darling Basin Plan (Basin Plan) was prepared by the Murray-Darling Basin Authority (MDBA) and signed into law by the Commonwealth Minister for Water on 22 November 2012, under the Commonwealth *Water Act 2007*. The *Intergovernmental Agreement on Implementing Water Reform in the Murray Darling Basin* subsequently outlined the commitments and responsibilities of the participating jurisdictions and the program for putting the Basin Plan into action.

The Basin Plan sets legal limits on the amount of surface water that can be extracted from the Murray-Darling Basin (the Basin) for consumptive use from 1 July 2019 onwards. The sustainable diversion limits (SDLs) for surface water are currently set at a reduction of 2,750 GL on current extraction levels. That SDL value has been modelled to create a certain level of environmental outcome. Under the provision in Chapter 7 of the Basin Plan and in the *Intergovernmental Agreement on Implementing Water Reform in the Murray Darling Basin*, it was agreed that the Basin Plan should be able to achieve these environmental outcomes by improved use and management of the water, as well as by reducing current extraction levels. That would allow the SDL reduction to be adjusted, reducing impacts on regional communities.

The Basin Plan allows for up to 650 GL of the 2,750 GL SDL reduction to be accounted for through this improved use and management of environmental water. The jurisdictions in the Basin states and the MDBA have established an inter-jurisdictional committee, the SDL Adjustment Assessment Committee (SDLAAC), to manage this process and to evaluate proposed investments.

The Basin states have developed a program to promote initiatives under these processes. SDLAAC has drawn up guidelines to help steer the drafting of business cases for such proposals.<sup>1</sup> Five different forms of intervention have been identified in the guidelines:

- **Environmental works and measures at point locations:** Infrastructure-based measures to achieve the Basin Plan's environmental outcomes at specific sites along the river using less environmental water than would otherwise be required.
- **Water efficiency projects:** Infrastructure-based measures that achieve water savings by reducing water losses through, for example, modified wetland or storage management.
- **Operating rules changes:** Changes to policies and operating rules that lead to more efficient use of water and savings and contribute to achieving equal environmental outcomes with less water.
- **Physical constraint measures:** Ease or remove physical constraints on the capacity to deliver environmental water.
- **Operational and management constraint measures:** Changes to river management practices.

This business case covers one such initiative regarding infrastructure-based measures at the Yanco Creek offtake on the Murrumbidgee River. This is a SDL adjustment supply measure project through 'environmental works and measures' intervention that achieves equivalent environmental outcomes with less water providing an opportunity to deliver a Sustainable

---

<sup>1</sup> SDLAAC 2014. *Phase 2 Assessment Guidelines for Supply and Constraint Measure Business Cases*



Diversion Limit adjustment. This business case has been prepared in accordance with the Phase 2 Assessment Guidelines (refer Appendix 1).

## 1.4 Terms of reference

This business case has been developed and prepared under the oversight of WaterNSW and the NSW Department of Primary Industries Water (NSW DPI Water). The terms of reference for this initiative are:

*The proposed supply measure is to construct a regulator on the Yanco Creek offtake and upgrade the existing Yanco Weirs on the Murrumbidgee River. The proposed structures will increase the frequency and efficiency of Murrumbidgee River flows that reach the target environmental watering sites in the Murrumbidgee (and Murray) Rivers and Yanco Creek system.*

This is an 'environmental works and measures at point locations' under the terms of the Phase 2 Assessment Guidelines as it involves the construction of works and measures. The outcome of this change will be to deliver equivalent environmental outcomes as proposed in the Basin Plan but with less water, so generating an SDL offset.

## 1.5 Background to the proposal

Yanco Creek was historically a high level effluent creek system connecting the Murrumbidgee River to the Murray River via a series of braided channels and wetlands. Prior to European settlement, the Yanco Creek system was predominantly an ephemeral system, meaning it often stopped flowing in low rainfall periods. At this time the Yanco Creek only engaged with the Murrumbidgee when flows were very high (>40,000 ML/d).

To develop and expand agricultural production, works were undertaken in the 1800's to join the Yanco Creek to the Murrumbidgee River. This allowed flows to the creek system when flows in the Murrumbidgee were quite low. In 1928 the Yanco Old Weir was installed to further facilitate diversion from the Murrumbidgee in almost all flow conditions.

In 1981 the new Yanco Weir was completed to raise Murrumbidgee River water levels to further increase low flow diversion rates into the creek system. Generally speaking, approximately 10% of water is now diverted into the Yanco Creek system.

The bulk of water supplied to Yanco Creek system from the Murrumbidgee River is via the Yanco off take although additional flows from the Murrumbidgee do enter the system from drainage channels out of the Coleambally Irrigation Area (the Coleambally Catchment Drain, Drainage Canal 800, West Coleambally Channel).

There are a number of key high value ecological sites in the mid and lower Murrumbidgee wetlands which are watered through water passing through the Yanco weir structure. The result of the historic diversion works to the Yanco Creek means a reduction in flows in the Murrumbidgee River, which reduces the environmental watering efficiency of the dam releases for these target sites.

Flow regulation on the Murrumbidgee also reduces the total volume of water available to the lower Murrumbidgee and can lead to reduced Murray River wetland inundation by changing the volume and timing of peak flows to the Murray.

This project involves installing greater control of water to manage flows down the Yanco Creek and improve the efficiency of delivery of environmental water to key assets in the mid-Murrumbidgee.

## 1.6 Proposed benefit of works

The principal benefit of these works is to deliver water more efficiently to the Mid Murrumbidgee wetlands.

The works improve fish passage. At present the Yanco weir and Yanco old weir represent major barriers to fish passage for both upstream and downstream migration. The project will incorporate the provision of a fishway on the main river as well as a fishway at the new Yanco Creek regulator. This will enhance the ecological and environmental outcomes in the Murrumbidgee River.

Raising the weir pool level at Yanco weir will allow more efficient delivery of targeted environmental flows in Yanco Creek by virtue of the increased hydraulic gradient. This will allow water to be delivered more efficiently and provide better environmental outcomes. It is proposed not only to reinstate the environmental flows in Yanco creek but will also provide the ability to introduce flow variability (overbank, bankfull, freshes and baseflow) as recommended by environmental flow study (Alluvium 2013).

## 1.7 Eligibility

The works proposed for the *SDL Offsets in the Yanco regulator* project meet the eligibility criteria for Commonwealth supply measure funding as a 'new measure'.

The project meets the definition of a 'supply measure' under the Basin Plan as they are additional to the measures included in the benchmark conditions of development under clause 7.02 of the Plan.

The proposal is not a 'pre-existing' Commonwealth funded project, and have not been approved for funding by another organisation, either in part or in full, other than through financial support to develop this business case.

The operation of the measures will allow for an increase in the SDL through improved management of the land, water and ecological resources in the Yanco Creek and Mid Murrumbidgee wetlands. The measures will:

- increase the quantity of water available to be taken in a set of surface water SDL resource units compared with the quantity available under the benchmark conditions of development;
- provide equivalent environmental outcomes with a lower volume of held environmental water than would otherwise be required to be achieved;
- have no detrimental impacts on reliability of supply of water to holders of water access rights that are not offset or negated; and
- be designed, implemented and operational by 30 June 2024.

This business case demonstrates how each eligibility requirement in the Phase 2 SDLAAC Guidelines is met. However, the ultimate outcomes of the proposal will depend on the modelling of different combinations of SDL offset proposals to be completed in 2016 by the Murray-Darling Basin Authority.

## 1.8 Proponent and proposed implementing entity

WaterNSW is the project proponent on behalf of the New South Wales Government and has prepared this business case in consultation with the NSW DPI Water, NSW Office of Environment and Heritage, NSW Parks and Wildlife, NSW Fisheries, the MDBA and the Commonwealth Department of the Environment through funding from the Australian Government.

WaterNSW is the project owner and will have oversight responsibility for project implementation. Further information regarding the proposed governance and project management arrangements for implementation is provided in Section 8.5.

## 2 Project details

### 2.1 Locality

The Yanco Creek system is a channel and floodplain system that commences from the Murrumbidgee River at Yanco Weir located about 20 km west of Narrandera. The 'Yanco Creek system' consists of a series of creeks including Yanco, Colombo, Billabong and Forest Creeks on the southern side of the Murrumbidgee (Figure 1 Figure 1).

The site of the Yanco Creek off take is located at the confluence of the Murrumbidgee River and Yanco Creek (Figure 2).

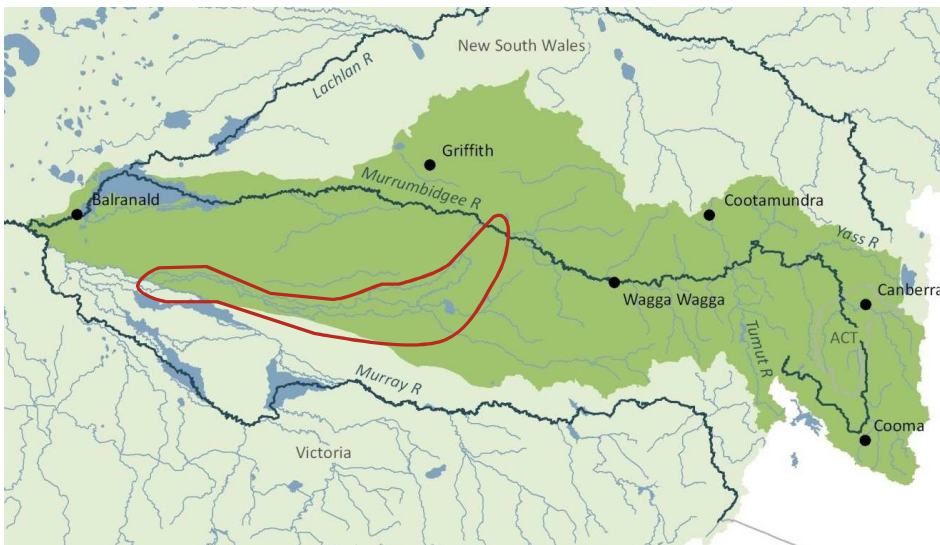

Figure 1. Murrumbidgee catchment - Yanco Creek system circled in red



Figure 2. Location of Yanco offtake

## 2.2 Proposed works package and adjustment

The new regulator in Yanco Creek will mean that water that is intended for the mid-Murrumbidgee wetlands is not shared with Yanco Creek, which receives about 10% of Murrumbidgee flows in its current unregulated condition. The new regulator will facilitate more efficient delivery of environmental water to the Murrumbidgee Wetlands. The new regulator is designed to target the supply of environmental flows of up to 45,000 ML/d for the Mid Murrumbidgee Floodplain Wetlands– the basis for this target flow rate is described later in Section 2.5.1. The proposed works include:

- A regulator on Yanco Creek that can manage flows of up to 45,000ML/d in the river.
- Infrastructure that allows the level of the weir pool at the Yanco offtake to be raised to a level, such that the flows excluded from the Yanco Creek in times of environmental watering of Murrumbidgee wetlands, can be delivered specifically to the Yanco Creek at a more appropriate time. This requires changes to the existing arrangements for the Yanco Regulator (on the Murrumbidgee River) and Yanco weir.
- Fishway at the new Yanco Creek Regulator to mitigate the fish barrier that the structure represents
- Fishway at the Yanco Regulator and/or weir as part of the upgrade works on these structures.

## 2.3 Interaction with other initiatives

Outcomes achieved with this supply measure will be enhanced through the implementation of other Murrumbidgee supply measures for which Phase 2 business case documentation is currently being developed.

### 2.3.1 CARM

The Murrumbidgee Computer Aided River Management (CARM) system is a river operations decision support system, developed and implemented by WaterNSW. It is underpinned by internationally-recognised hydro-dynamic, rainfall runoff, and surface/ground water exchange models.

These models, coupled to Bureau of Meteorology forecasting, future crop water demand estimations, water orders and reporting of real time water extraction, combine to enable an innovative interactive daily river operating system. This proposal outlines the potential supply measure associated with recent deployment of CARM for the Murrumbidgee River

The project will change how the Murrumbidgee River is operated, reducing the amount of operational surplus flows in the river system and allowing some of this water to be released at a more opportune time to the environment. It will increase the river operator's level of control over river flows and provide greater daily real time flexibility and efficiency in how water is managed in the river.

Supply contributions through use of CARM will occur principally through two mechanisms as a result of improved river operational practices. These are:

- reduction in operational losses, thereby creating stored surplus that is not associated with third parties; and

- re-timing the regulated release of previous substantial river system operational surpluses captured through CARM to also simultaneously meet specific flow indicators targets

### 2.3.2 Modernising effluent creeks

This project has a close fit with the modernisation of the effluent creeks Phase 2 Business Case. The creeks around the Yanco weir are important supply systems for irrigated production and for stock and domestic supply. The creeks include,

- Forest Creek - an anabranch of the Billabong Creek down to Warriston Weir
- Yanco Creek itself - downstream of the Colombo Creek off-take until its junction with Billabong Creek near Conargo
- Colombo and Billabong Creeks - from the Colombo Creek offtake to the confluence of the Billabong Creek with the Edward River
- Beavers Creek/Old Man Creek - an anabranch of the Murrumbidgee between Wagga and Narrandera
- Bundidgerry Creek - a natural high level effluent creek system from the Berembed offtake to the Bundidgerry storage

Prior to irrigation development, these creeks, anabranches, effluents and flood runners would have experienced highly variable flows within and between seasons. That variability generates a rich ecological outcome from the cyclical wetting and drying regime, with complex food chains supporting extensive bird breeding.

The development of the creeks as part of the station stock-watering network, and more recently as a regional irrigation supply system has over-ridden this natural variability and imposed standardised, consistent high flows during summer months every year. These constant high flows generate several adverse outcomes.

- They disrupt natural wetting and drying cycles and reduce the ecological richness of the habitat -reducing fish and bird breeding.
- They lead to increased losses through evaporation and seepage - so water is wasted that could be used to deliver planned environmental flows.
- Over-supply is common because it is difficult to match water orders with daily deliveries to Irrigator pumps due to the length of the delivery system.

This project proposes to identify fit-for-purpose alternative systems that could ensure continuity of water supply for production and D&S usage, at the same time as generating water savings and returning more natural variability of flows to the creeks.

These fit-for-purpose alternative supply systems could include a range and combination of different options including:

- Piped stock and domestic systems
- Gravity piped irrigation supply systems
- Irrigation supply channel extension where available
- Enhanced river weir operations (linking with WaterNSW's CARM network)
- The use of public and privately owned off-river storages
- Automated river operations systems (linking with WaterNSW's CARM network)

- Targeted closure of high-loss supply effluent streams – possibly through buyback or development of alternative supply points.

### 2.3.3 Constraints management strategy

Constraints are river management practices and structures that govern the volume and timing of regulated water delivery through the river system. Seven key focus areas in the Basin are identified where the relaxation of constraints needs detailed consideration. The Murrumbidgee is one of these.

While the 2,750 GL of environmental water can be delivered within the current physical constraints, relaxing or removing key constraints would allow for more flexibility in water delivery, which means we can achieve even more with the water available. The MDBA has produced a Constraints Management Strategy to investigate how this can be done in ways that avoid or address impacts on third parties, and therefore optimise environmental, social and economic benefits.

In addition to the physical constraints, there are a range of operational and management constraints that are relevant across a range of geographic areas across the Basin.

Potential constraints to environmental water delivery in the Murrumbidgee include areas in the vicinity of:

- Gundagai, including the low level Mundarlo Bridge;
- the channel capacity of the Tumut River;
- Collingullie
- Upper Yanco Creek
- Darlington Point
- the channel capacity of the Murrumbidgee River near Balranald

This SDL adjustment proposal complements the constraints management strategy by providing the ability to control high flows down the creek and avoid overbank events in Upper Yanco Creek at undesirable times. The Yanco Creek regulator is the critical component of achieving control of high flows and mitigating flooding impacts.

### 2.3.4 Nimmie- Caira Infrastructure Modifications Proposal and Murray and Murrumbidgee National Parks SDL Adjustment Proposal

In addition to the above mentioned supply measures, there are a range of SDLA proposals in Murrumbidgee Valley which have the potential to be complemented. Particularly the Nimmie-Caira Infrastructure Modifications Proposal and Murray and Murrumbidgee National Parks SDL Adjustment Proposal will be complemented by virtue of increasing the delivery of environmental flows to this area and helping to offset any downstream effects of any increased environmental water use in Lowbidgee area.

## 2.4 Current hydrology

The changes to the flow regime in the central section of the Murrumbidgee River have had a significant impact on the hydrology of the Mid-Murrumbidgee River Wetlands (MDBA 2012). Wetlands influenced by weir pools, irrigation storage and effluent are now almost permanently inundated, and low-lying wetlands upstream of Berembed Weir are often inundated by summer

irrigation releases (Frazier et al. 2003, MDBA 2012). However, the inundation frequency has halved for wetlands between Gundagai and Hay, with river connections higher than the level of irrigation flows (Frazier et al. 2003, MDBA 2012).

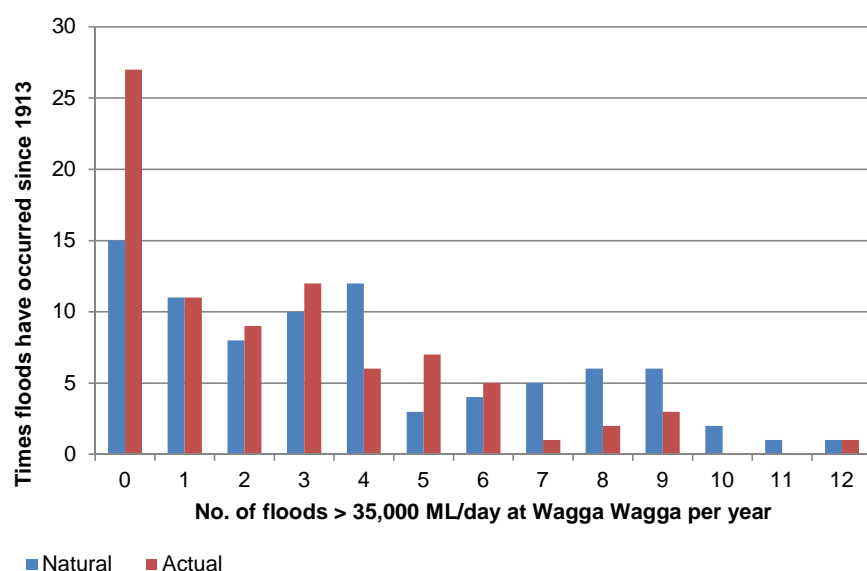

Figure 3. Comparison of without-development and actual flows at Wagga Wagga, 1913–96: Mid-Murrumbidgee River Wetlands. (Source: reproduced from Whitten and Bennett 2000, MDBA 2012).

The Mid-Murrumbidgee Wetlands have been in a critical condition and declining by the end of the millennium drought. Many areas had not been inundated for 5–14 years at that time. Natural floods since 2010 and the use of Commonwealth and NSW environmental water in 2011 have aided the recovery of these wetland communities (Wassens et al. 2012), but additional watering actions are required before these wetlands are likely to recover to their pre millennium drought state (Wassens et al. 2014). (CEWO 2014)

This area was an environmental watering priority for 2013–14 (MDBA 2014b; NSW Office of Environment and Heritage 2013; Commonwealth Environmental Water Office 2013a), however planned use of Commonwealth environmental water for the Mid-Murrumbidgee Wetlands in spring 2013 did not proceed due to third party impact concerns and approvals required in relation to the Yanco Creek offtake flow limit which prevented the delivery of the desired flow regime (CEWO 2014).

#### 2.4.1 Current hydrology - Mid -Murrumbidgee

The natural flow regime of the Murrumbidgee River was characterised by low average flows in summer and autumn and higher average flows in winter and spring (Page et al. 2005). Flows in the Murrumbidgee River would have naturally been quite variable, with rainfall events in the upper- and mid-catchment creating flow pulses that would have travelled down the river for most of its length (Watts 2010).

A number of dams have been built on the Murrumbidgee River and its tributaries and this river regulation has considerably altered the flow regime in terms of total volume, seasonal patterns of discharge, magnitude and frequency of floods, and frequency and duration of floodplain inundation (Watts 2010).



The critical threshold for connection for a number of low-lying wetlands is a flow of 26,850 ML/d at Narrandera, with many more wetlands requiring larger flows to be connected. Over the millennium drought period (2000 – 2010) a large proportion of mid-Murrumbidgee wetlands did not naturally connect with the Murrumbidgee River.

Under modelled 'without development' conditions, wetlands with commence to flow rates of 26,850 ML/d would have a maximum dry period of 5 years (MDBA 2012c).

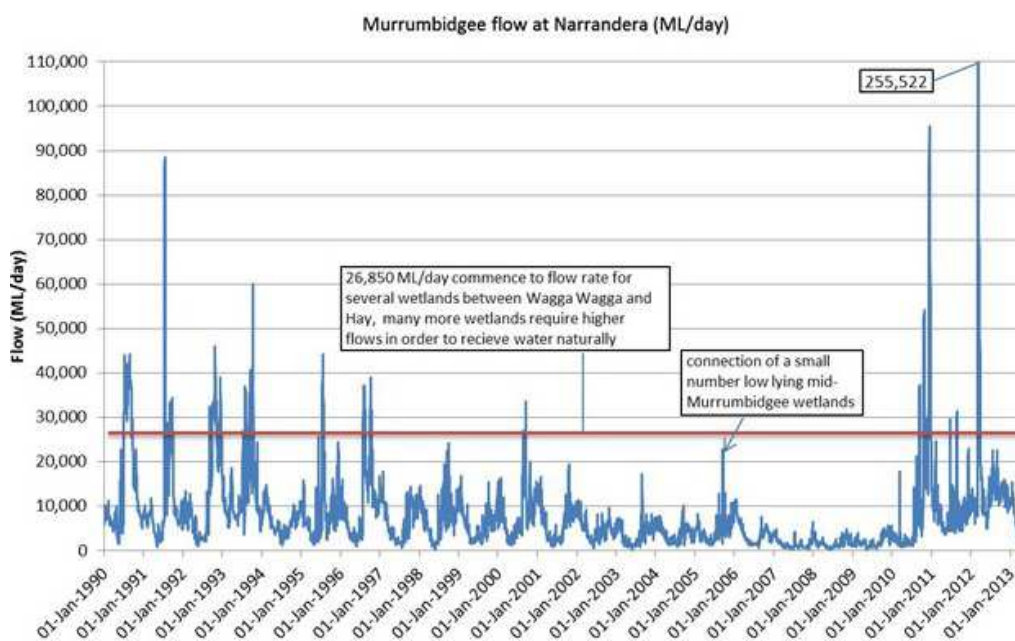

Figure 4. Flow rates of the Murrumbidgee River at Narrandera from 1990 to April 2013, showing one of the critical thresholds for inundation of mid-Murrumbidgee wetlands as specified in the Assessment of environmental water requirements for the proposed Basin Plan: Mid-Murrumbidgee River Wetlands (MDBA 2012d) (<http://www.mdba.gov.au/what-we-do/environmental-water/environmental-watering-priorities/priorities-13-14/mid-murrumbidgee>)

A comparison of observed flows with modelled natural flows for the period 1970 to 1998 shows that river regulation has significantly reduced the magnitude of the smaller, relatively frequent floods (Read 2001). Flood discharges that would typically occur every two years have been reduced by between 29% and 37% from Gundagai downstream to Hay and by about 55% at Balranald. The reduction is less for floods that would typically occur every five years, ranging from a 16% reduction at Narrandera to a 36% reduction at Balranald.

Flow regulation has also affected the frequency and duration of floodplain inundation. Read (2001) demonstrated that the duration of bankfull flow has been reduced by regulation, and has resulted in an approximate halving of the duration of floodplain inundation.

This conclusion is supported by Page et al. (2005) who found that between Gundagai and Balranald, regulation had, for flood return periods of 1.25 to 5 years, reduced discharges by 25–40%.

The Murray–Darling Basin Sustainable Yields Project by CSIRO (2008) showed that the average period between events with peak flows greater than 26,800 ML/d at Narrandera had

nearly doubled as a result of water resource development. In addition, they found that the maximum period between these events had more than tripled (from 2.8 to 9.7 years).

Whitten and Bennett (2000) found that the frequency of flows in excess of 35,000 ML/d at Wagga Wagga had been reduced while the number of years with no flows greater than 35,000 ML/d had increased significantly (Figure 3).

#### **2.4.2 Current hydrology - Yanco Creek system**

Irrigation works in the last century have significantly altered the Yanco Creek system flow regime. Prior to irrigation development, the system would have flowed only when flooding was occurring in the Murrumbidgee River (flows >40GL/d at the Yanco offtake) and/or when there was substantial runoff and flows in the upper catchment of Billabong Creek (Molino Stewart 1999).

Both Yanco Creek and Billabong Creek also receive inflows from drains and/or tributary streams. Yanco Creek receives flows from the Coleambally Catchment Drain (CCD) and drain DC 800, both of which carry drainage flows and regulated releases from the Coleambally Irrigation Area.

The Billabong Creek receives inflows from a number of creeks and drains, namely the upper (or unregulated) Billabong Creek which has a catchment that extends 160km to the east of Colombo Creek (Molino Stewart 1999). Murray Irrigation Limited (MIL) delivers drainage water and some regulated flows to the Billabong and Forest Creeks. The main MIL channel used for regulated flows is Finley Escape.

### **2.5 Ecological Assets**

#### **2.5.1 Mid-Murrumbidgee River Wetlands**

The Mid-Murrumbidgee River Wetlands support the functioning of the Murrumbidgee River, the second longest River in the Murray-Darling Basin, by providing an important input of carbon and nutrients as well as important habitat for fish, frogs, turtles and birds. The area is formed around an assemblage of lagoons and billabongs located on the floodplain of the central Murrumbidgee River between Wagga Wagga and Carrathool (Figure 5).

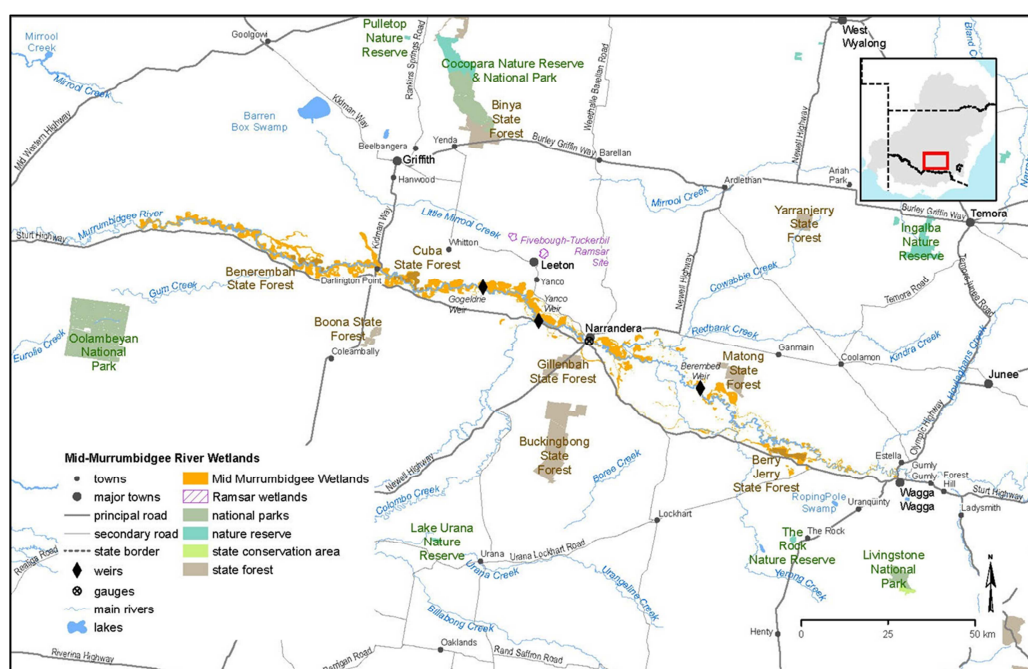

Figure 5. Mid Murrumbidgee wetlands

The existence of extensive floodplains and remnants of a paleo (old) river system has resulted in the formation of a large number of natural closed depressions on the mid-Murrumbidgee floodplain. The Murrumbidgee wetlands are good examples of inland river and lagoon wetlands of which a selection is listed in the Directory of Important Wetlands of Australia (Environment Australia 2001).

Using satellite imagery of flood events between 1989 and 1997, approximately 1,600 floodplain wetlands were identified between Gundagai and Hay (Frazier 2001; Murray 2006), with most located between Wagga Wagga and Carrathool (Frazier and Page 2006). Analyses conducted by WaterNSW to inform the Constraints Management Strategy indicate 3165 ha of wetlands in the Mid-Murrumbidgee wetlands area.

Terrestrial vegetation of the Mid-Murrumbidgee River Wetlands is dominated by River Red Gum (*Eucalyptus camaldulensis*) which forms a continuous band along the river (Briggs et al. 1994). In the downstream section of the mid-Murrumbidgee floodplain system Black Box woodlands (*E. largiflorens*) become a common feature on higher ground away from the river (Briggs et al. 1994). Lagoons and swamps occur along the river and fill from high flows. Aquatic vegetation occurs in these areas, especially when the lagoons and swamps are shallow (Briggs et al. 1994). These communities combine to form a variety of key habitats including:

- a range of riparian and wetland vegetation communities that are critical to several fish species in the Murrumbidgee (Gilligan 2005);
- approximately 45,000 ha of River Red Gum wetlands between Wagga Wagga and Hay Weir (Thornton and Briggs 1994) which have been shown to be important areas for waterbirds including breeding of colonial nesting waterbirds (Briggs et al. 1994; Briggs et al. 1997; Briggs and Thornton 1999; Kingsford et al. 1997); and
- habitat for a range of species and communities listed as threatened under both Commonwealth and state legislation.

The mid-Murrumbidgee wetlands support many rare and threatened fauna species including the Environment Protection and Biodiversity Conservation Act 1999 (the EPBC Act) listed endangered Trout Cod (*Maccullochella macquariensis*), the vulnerable southern bell frog (*Litoria raniformis*) and numerous bird species.

The wetlands also support internationally listed migratory species such as the Cattle Egret (*Ardea ibis*), Eastern Great Egret (*Ardea modesta*), Glossy Ibis (*Plegadis falcinellus*), Latham's Snipe (*Gallinago hardwickii*) and the White-Bellied Sea-Eagle (*Haliaeetus leucogaster*) (MDBA 2010c).

As set out above, the ecological assets of the Mid-Murrumbidgee River Wetlands clearly meet the criteria for identifying an 'environmental asset' as set out in the Basin Plan (refer Figure 4 for details) and Water Act 2007 (Cwlth).

The criteria for identifying an 'environmental asset' are detailed in Clause 8.49 and Schedule 8 of the Basin Plan. In summary, these criteria require that one or more of the assessment indicators are met for any of the following five criteria:

Criteria	Assessment indicators
1: The water-dependent ecosystem is formally recognised in international agreements or, with environmental watering, is capable of supporting species listed in those agreements	<ul style="list-style-type: none"> <li>• Ramsar wetland</li> <li>• Species listed in or under the JAMBA, CAMBA, ROKAMBA or the Bonn Convention.</li> </ul>
2: The water-dependent ecosystem is natural or near-natural, rare or unique	<ul style="list-style-type: none"> <li>• Represents a natural or near-natural example of a particular type of water-dependent ecosystem</li> <li>• Represents the only example of a particular type of water-dependent ecosystem in the MDB</li> <li>• Represents a rare example of a particular type of water-dependent ecosystem in the MDB</li> </ul>
3: The water-dependent ecosystem provides vital habitat	<ul style="list-style-type: none"> <li>• Provides refugium for native water-dependent biota during dry spells and drought</li> <li>• Provides pathways for the dispersal, migration and movements of native water-dependent biota</li> <li>• Provides important feeding, breeding and nursery sites for native water-dependent biota</li> <li>• Is essential for maintaining, and preventing declines of, native water-dependent biota.</li> </ul>
4: Water-dependent ecosystems that support Commonwealth, State or Territory listed threatened species or communities	<ul style="list-style-type: none"> <li>• Supports a listed threatened ecological community or listed threatened species</li> <li>• Supports water-dependent ecosystems treated as threatened or endangered</li> <li>• Supports one or more native water-dependent species treated as threatened or endangered</li> </ul>
5: The water-dependent ecosystem supports, or with environmental watering is capable of supporting, significant biodiversity	<ul style="list-style-type: none"> <li>• Supports significant numbers of individuals of native water-dependent species</li> <li>• Supports significant levels of native biodiversity at the genus or family taxonomic level, or at the ecological community level.</li> </ul>

Figure 4. Summary of the criteria for identifying an 'environmental asset' as set out in the Basin Plan

Flows from the Murrumbidgee River have been identified as an important contributor to environmental outcomes in the mid to lower reaches of the Murray River. As such the priority

outcomes within the Murrumbidgee should also be considered in conjunction with the priority outcomes for the *mid-Murray River, lower Murray River system, Coorong, Lower Lakes and Murray Mouth*, and other environmental outcomes in the southern-connected Basin.

### 2.5.1.1 Ecological objectives and targets

The Basin Plan provides a coordinated approach to water use across the Murray Darling Basin and has been developed under the *Water Act 2007* (Cwlth). It aims to provide integrated management of the Basin water resources in a way that promotes the objectives of the *Water Act 2007*. In the context of a healthy working Basin, the Basin plan contains four high-level environmental objectives/outcomes (MDBA 2011, pp. 22):

- to protect and restore water-dependent ecosystems of the Basin
- to protect and restore the ecosystem functions of water-dependent ecosystems
- to ensure that water-dependent ecosystems are resilient to risks and threats
- to ensure that environmental watering is co-ordinated between managers of planned environmental water, owners and managers of environmental assets, and holders of held environmental water.

At a finer scale, the Basin Plan Environmental Watering Plan sets out 22 subsidiary environmental objectives. The MDBA has used these detailed objectives to determine ecological targets, environment water requirements and ultimately Environmentally Sustainable Level of Take (ESLT) for the basin as a whole.

The Basin-wide ecological targets are that there are improvements in:

- flow regimes including the following flow components; cease-to-flow events, low-flow-season base flows, high-flow-season base flows, low-flow-season freshes, high-flow-season freshes, bank-full flows and over-bank flows
- hydrologic connectivity between the river and floodplain and between hydrologically connected valleys
- floodplain and wetland types including the condition of priority environmental assets and priority ecosystem functions
- condition of the Coorong and Lower Lakes ecosystems and Murray Mouth opening regime
- condition and diversity of native water-dependent vegetation
- recruitment and populations of native water-dependent species, including vegetation, birds, fish and macro-invertebrates.

Ultimately, the level to which these ecological objectives or targets are met are dependent on environmental flow decisions made at a regional and local scale. The set of Basin-wide environmental objectives and ecological targets developed by the MDBA have been applied at a finer scale to develop site-specific objectives for individual key environmental assets.

Site-specific ecological targets developed to inform the assessment of environmental water requirements and the subsequent determination of site-specific flow indicators for the Mid-Murrumbidgee River Wetlands (MDBA 2012) in the Basin Plan are described in Table 1.

Table 1. Environmental objectives and targets: Mid Murrumbidgee River Wetlands (MDBA 2012)

<b>Site-specific ecological targets</b>	<ul style="list-style-type: none"> <li>• Provide a flow regime which ensures the current extent of native vegetation of the riparian, floodplain and wetland communities is sustained in a healthy, dynamic and resilient condition.</li> <li>• Provide a flow regime which supports recruitment opportunities for a range of native aquatic species (e.g. fish, frogs, turtles and invertebrates).</li> <li>• Provide a flow regime which supports key ecosystem functions, particularly those related to connectivity between the river and the floodplain.</li> <li>• Provide a flow regime which supports the habitat requirements of waterbirds and is conducive to successful breeding of colonial nesting waterbirds.</li> </ul>
<b>Justification of targets</b>	<p>The number and extent of floodplain wetlands is a distinctive feature of the Mid-Murrumbidgee River Wetlands. Relatively intact flood-dependent vegetation communities provide crucial habitat for numerous conservationally significant fauna species and are targeted for inundation through several of the Specific Flow Indicators set by MDBA..</p> <p>Studies by Briggs et al. (1997), Briggs et al. (1994), Briggs and Thornton (1999) and Kingsford et al. (1997) have shown that the mid-Murrumbidgee is an important area for waterbirds including breeding of colonial nesting waterbirds.</p> <p>The Mid-Murrumbidgee River Wetlands contain a range of riparian and wetland vegetation communities that are critical to several fish species in the Murrumbidgee (Gilligan 2005).</p> <p>The variety of faunal groups that can be supported at individual sites is demonstrated by referring to Coonancoocabil Lagoon, one of the larger wetlands in the system. It is important for waterbirds (Briggs et al 1997), frogs (Wassens et al. 2004), and native fish (Baumgartner and Asmus 2009).</p> <p>The site supports important habitat and species that are listed in international agreements, and include vulnerable and endangered species such as Murray cod (<i>Maccullochella peelii peelii</i>). Achieving the targets for floodplain wetlands and waterbirds will ensure inundation of breeding and feeding habitats considered key for a range of fish, amphibian and water-dependent reptile and invertebrate species.</p> <p>Key ecosystem functions support fish, birds and invertebrates through habitat maintenance, energy transfer and facilitating connections between rivers and floodplains. Overbank flows supply the floodplains with nutrients and sediments from the river, accelerate the breakdown of organic matter and supply water to disconnected wetlands, billabongs and oxbow lakes. As the floodwaters recede, the floodplains provide the main river channel with organic matter.</p> <p>The hydrological connection between watercourses and their associated floodplain provides for the exchange of carbon and nutrients (Thoms 2003). The connections are considered essential for the functioning and integrity of floodplain-river ecosystems.</p>

### 2.5.1.2 Site-specific indicators for the Mid Murrumbidgee Floodplain Wetlands

Through the development of the Basin Plan, detailed environmental water requirement assessments were undertaken across the Basin, leading to the specification of site-specific flow indicators (SFIs) to achieve site-specific ecological targets. These site-specific flow indicators were expressed only at hydrologic indicator site, with the environmental water requirements specified at hydrologic indicator sites intended to represent the broader environmental flow needs of river valleys or reaches through the Basin, and thus the needs of a broader suite of ecological assets and functions.

This process resulted in the development of the following SFIs to represent the environmental water requirements of the Mid Murrumbidgee Floodplain Wetlands indicator site:

- 26,850 ML/d for a total duration of 45 days between July & November for 20% of years
- 26,850 ML/d for 5 consecutive days between June & November for 50% of years
- 34,650 ML/d for 5 consecutive days between June & November for 35% of years
- 44,000 ML/d for 3 consecutive days between June & November for 30% of years
- 63,250 ML/d for 3 consecutive days between June & November for 12% of years

These SFIs correspond to flow rates as measured at Narrandera on the Murrumbidgee River.

In developing these SFIs, it was recognised that not all SFIs could necessarily be delivered in regulated systems subject to significant existing constraints. In particular, the report on the development of the SFIs (*The proposed "environmentally sustainable level of take" for surface water of the Murray–Darling Basin: Method and Outcomes – MDBA 2011*) noted that:

- the 26,850 ML/d SFIs are considered deliverable as mostly regulated flows under current operating conditions
- the 34,650 and 44,000 ML/d SFIs are considered achievable when delivered in combination with tributary inflows and/or unregulated flow events, but may not be achievable in every year or some circumstances, and the duration of flows may be limited to the duration of tributary inflows
- the 63,250 ML/d SFI requires large unregulated flows and it is likely that it cannot currently be influenced by river operators due to river operating constraints.

With these constraints in mind, this proposal therefore is focused on delivery of environmental water for the SFIs ranging from 26,850 to 44,000 ML/d only. The proposal does not provide a mechanism to regulate flow to achieve the 63,200 ML/d SFI.

### **2.5.2 Yanco Creek system**

The Yanco Creek system is around 800 kilometres in length and supplies water to a vast area of the Riverine Plains of New South Wales for agricultural production and also water supply for townships of Morundah, Urana, Oaklands, Jerilderie, Conargo and Wanganella. Along the system there are a number of environmental assets including significant wetland areas that have been impacted by historic water management practices. The community along the creek system is committed to improving the ecological health of all the system and has initiated and/or supported several studies and environmental restoration programs, particularly for riparian habitat.

From the offtake from the Murrumbidgee River to where Billabong Creek connects to the Edward River, the Yanco system supports a largely continuous band of riparian vegetation that is dominated almost entirely by River Red Gum and Black Box (in a few locations, River Cooba is also present as a canopy-forming tree). The system also supports both some large wetlands, as well as a large number of smaller floodplain depressions and billabongs.

The physical form and condition of ecological values in the Yanco Creek system is shaped not only by the regulation of water, but by the spatial and temporal variability of this supply. That is, both physical form (the shape of the waterway) and ecological values such as fish and vegetation are driven by the hydrological behaviour of the system.

A wide range of floodplain wetlands are present in the upper Yanco, including the Possum Creek complex, Dry Lake and Mollys Lagoon, and the Washpen Creek complex. These are characterised by large expanses of open water.

In addition to these large and visually obvious floodplain wetlands, the Yanco system supports a large number of smaller floodplain depressions and billabongs and are fringed mostly by River Red Gum (Figure 6). Forest Creek also supports the regionally important Wanganella Swamp and Rhyola wetland. Of these, Wanganella Swamp is the more floristically diverse and its water-regime requirements have been addressed in a number of studies.

Overbank flows are important to the health of the riparian and wetland vegetation communities. The overall ecological resilience of the system is enhanced by providing hydrological conditions that facilitate the maintenance of such a mosaic of wetlands under different hydrological regimes.

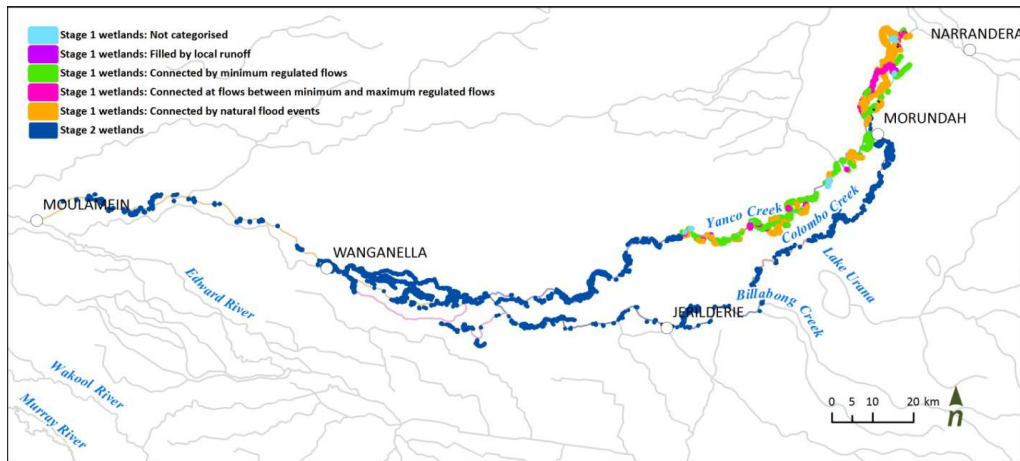

Figure 6. Wetlands mapped in the Yanco Creek system through two previous projects –Investigation into potential water savings from the Yanco Creek system (offtake to Yanco Bridge) wetlands (Webster 2007) (referred to as Stage 1), and the follow-on Stage 2 study (GIS data only, Webster unpublished)

A key environmental value in the Yanco is the presence of several large-bodied fish which are nationally threatened and remain in areas where there is permanent flow and good instream habitat. This includes species such as Murray Cod and Trout Cod. Additionally, there are still strong and healthy populations of small bodied native fish in the Yanco system.

As described above, the ecological assets of the Yanco Creek system also meet the criteria for identifying an 'environmental asset' as set out in the Basin Plan (refer Figure 4 for details) and Water Act 2007 (Cwlth).

### 2.5.3 Yanco Creek ecological objectives and targets

Broad environmental objectives determined in the environmental flows study (Alluvium 2013) for the Yanco Creek system were:

- Maintain (and improve where possible) drought refuge habitat in weir pools.
- Improve riparian vegetation condition and habitat extent throughout the system.



- Preserve the significant connectivity between the Murrumbidgee and Murray River systems that is important for native fish communities.
- Retain a high quality mosaic of wetlands with variable wetting regimes which provide habitat for fish and water birds.

The environmental objectives were developed to reflect the environmental values identified by the community, through literature review, and assessment by the project Technical Panel for the Yanco Environmental Flow Study (Alluvium 2013). Objectives were determined by the Technical Panel and Steering Committee for the system and each study reach, and are set in the context of the current water resource management, and social and economic values of the region.

Environmental flow targets for the Yanco Creek system, as described in Alluvium 2013 are described below:

#### **Fish movement, spawning and recruitment**

Native fish populations have declined in many areas of the Murray-Darling Basin and this has often been associated with river regulation and habitat removal. Several large-bodied fish are nationally threatened and remain in areas where there is permanent flow and good instream habitat, such as the Murrumbidgee River and Yanco Creek system (such as Murray Cod and Trout Cod). Additionally, there are still strong and healthy populations of small bodied fish in both the Yanco and the broader Murrumbidgee systems. Small native fish are important indicators of functioning systems and these play an important role in a healthy and diverse fish community.

Delivery of appropriate flows to maintain habitat availability and to stimulate movement, spawning and recruitment is important to maintain the health of existing populations and maximise their distribution. The recommended system-wide environmental flows are:

- Provide baseflows<sup>2</sup> throughout the system to allow fish movement between local habitats (in accordance with reach targets outlined in the report). This recommendation correlates to a target end of system baseflow recommendation of 50 ML/d (Jan-Apr) and 200 ML/d (May-Dec), on condition that the baseflow targets in the upper part of the system are also met.
- Provide freshes in the upper reaches of the system connected to the Murrumbidgee fish communities. Flow magnitude is recommended to be above 600 ML/d (Reach 1 – Yanco Creek from offtake to Colombo Creek) and 350 ML/d (Reach 2 – Yanco Creek downstream of Colombo Creek) for 14-21 days to provide conditions suitable for large-bodied fish (e.g. Trout Cod) movement and spawning. Two events are recommended each year in the period from September to December.
- Provide freshes in the lower reaches of the system connected to the Edward fish communities. To connect with the fish communities in the Edward, it is recommended that:
  - During January-April four small freshes of 200 ML/d (7 days duration) are provided in lower Billabong Creek (Reach 5 – Billabong Creek downstream of

---

<sup>2</sup> While the baseflow recommendation is expressed as a constant minimum flow rate, it is critical that there is variability within the provision of this recommendation (i.e. water level fluctuations). Constant water levels in the system favour the proliferation of *Typha* (Cumbungi) and also create notches in the banks, leading to simplification of channel form and reduction in bench habitat. The impacts of constant flow rates are currently evident in the system, for example *Typha* infestations in Colombo Creek and the steep, simplified banks evident along the upper Yanco Creek.

Yanco Creek) to increase the habitat available (above the baseflow water level) and encourage fish to feed and spawn on benches.

- One fresh above 700 ML/d for fish movement and spawning, preferably in September- October with duration of 14-21 days.
- One fresh greater than 1500 ML/d fish movement and spawning, preferably in September- October with duration of 14-21 days.
- Protect overbank flows throughout the system. Connectivity between the creek and floodplain is important for the dispersal and breeding of floodplain specialist fish species. These overbank events are not required as frequently as other native fish species. However, when overbank flows occur in the Yanco Creek system it is important that the water level is over the top of the bank for 2-5 days.

### Riparian and wetland vegetation condition and connectivity

From the offtake from the Murrumbidgee River to where Billabong Creek connects to the Edward River, the Yanco system supports a largely continuous band of riparian vegetation that is dominated almost entirely by River Red Gum and Black Box (in a few locations, River Cooba is also present as a canopy-forming tree). The system also supports both some large wetlands, as well as a large number of smaller floodplain depressions and billabongs.

Overbank flows are important to enhance the health of the riparian and wetland vegetation communities. These large flows have historically been out of operating range for water managers to deliver to the Yanco Creek, rather the overbank flows have resulted from large rainfall in upstream and local catchments. It is important to preserve these flooding flows when they do occur, and also to monitor vegetation condition during extended dry periods when there are no overbank flows.

The magnitude for the recommended environmental flows for riparian and wetland vegetation relate to the discharge at which water begins to overtop the riverbank at the representative assessment site (Table 2). It is anticipated that throughout the system there will be some locations where overbank flow actually occurs at flows higher and/or lower than that recommended in Table 2.

Table 2. Flow recommendations for riparian and wetland vegetation in the Yanco Creek system

Reach	1	2	3	4	5	6
<b>Magnitude</b>	2500 ML/d	1000 ML/d	1600 ML/d	3000 ML/d	3000 ML/d	1500 ML/d
<b>Timing</b>	September to December					
<b>Frequency</b>	1 every second year	1 every third year	1-2 every ten years	1 every third year	1 every second year	1 every ten years
<b>Duration</b>	Minimum 2 days duration of peak event					
<b>Notes</b>	<p>Many of the wetlands in the upper section of the Yanco (reaches 1 and 2) are impacted by overwatering. Flow could be provided and/or controlled through regulators to individual wetlands.</p> <p>Complementary riparian vegetation management (including stock exclusion) will be required in all reaches to achieve environmental objectives.</p> <p>Flow recommendations do not necessarily apply to environmental water management for specific wetland sites (such as Wanganella Swamp) where complementary and additional water management actions may be required.</p> <p>Reaches are as follows: 1 – Yanco Creek from offtake to Colombo Creek; 2 – Yanco Creek downstream of Colombo Creek; 3 – Colombo Creek; 4 – Billabong Creek downstream of Colombo Creek to Yanco Creek; 5 – Billabong Creek downstream of Yanco Creek; 6 – Forest Creek</p>					

Riparian vegetation condition and floodplain wetlands depend not only on hydrological factors but also on land use practices. In general, wetland plants cannot recruit successfully when

subject to high and constant grazing pressure, and the maintenance and rehabilitation of the system's complex array of wetlands (large and small) will require ancillary actions involving catchment management as well as the provision of environmental water.

### **Drought refuge – weir pools**

The potential for species to survive droughts depends on the availability of suitable and adequate habitat for biota to live during dry periods. Maintaining refuges during drought periods is essential if species are to continue into the future. Many of the natural drought refuges (deep pools, off-stream wetlands) have been reduced in size and occurrence across the Murray-Darling landscape. The weir pools present on the Yanco Creek system provide an opportunity to be managed as additional secure drought refuge areas.

Environmental flow recommendations to maintain drought refuge in existing weir pools in the system are:

- Maintain the level of water in the weir pools. Maintaining the water level will maximise habitat potential for macroinvertebrates, fish and water birds during dry years. This is required in all weir pools in the system, all year.
- Flushing flows are recommended when water quality in weir pools declines below acceptable levels during September to May. In these months the recommended environmental flows to prevent water quality decline are 55-105 ML/d in Reach 3 – Colombo Creek and between 40-70 ML/d in Reach 4 – Billabong Creek from Colombo Creek to Yanco Creek.

Although the system was clearly very ephemeral in a pre-development state, the objectives do not require returning the creeks to an ephemeral system as this would be too detrimental for the established flora and fauna, particularly the fish. However, the continuous nature of the current flows is potentially detrimental to the achievement of objectives. The environmental flows recommended promote greater variability in the flow regime to achieve:

- targeted fish spawning and migration events
- promote a variety of instream flow habitats
- shift sediment
- encourage diverse bank and instream vegetation to establish
- promote suitable wetting and drying regimes in wetlands to cycle and replenish nutrients.

If there is an ongoing commitment to maintain a continuous flow in the creek system, the need to retain weirs and block banks for stock and domestic supplies should be investigated. Many of the weirs are falling into disrepair with some having failed and now contributing to bank erosion.

### **Contribution of the Yanco Creek system to the Edward/Murray River**

The Yanco system is one of many catchment sources to the Edward-Wakool Rivers. The main sources of water in the Edward-Wakool under regulated conditions are from the River Murray via the Edward River and Gulpa Creek, which originate in the Barmah-Millewa and from the Edward Escape, an outlet of Mulwala Canal. During high flows, the Yanco system (via Billabong Creek) is the most downstream tributary that provides flow to the Edward River.

The flow regime in the Edward-Wakool has been significantly altered as a result of river regulation. The key parts of the flow regime that have been altered are:

- a reduction in the frequency of baseflow and cease to flow events

- a rapid rate of rise and fall in channels;
- a reduction in the duration of moderate floods;
- a change in seasonality of flows and a loss of freshes important for breeding cues

Inflows to the Edward River from Billabong Creek are most influential in contributing to sustaining the duration of moderate floods and provision of freshes. With implementation of the recommended environmental flows, further contribution to those flow components may be possible.

## 2.6 Environmental values

### 2.6.1 Fish

Fish communities within the Murrumbidgee catchment were comprehensively assessed in 2004 (Gilligan, 2005). These surveys described fish communities in the mid-Murrumbidgee as being degraded with eight of the 21 native fish species previously recorded being either locally extinct or occurring in very small numbers.

Within the Mid Murrumbidgee Wetlands only five fish species were recorded from three wetlands, and were dominated by introduced fish species, mainly *Gambusia* along with Carp, Goldfish and two native species Carp Gudgeon and Australian smelt were also recorded (Gilligan, 2005).

Several of the large-bodied fish which are nationally threatened do remain in areas where there is permanent flow and good instream habitat, such as the Murrumbidgee River and Yanco Creek system (such as Murray Cod and Trout Cod). Additionally, Gilligan 2005 noted that there are still strong and healthy populations of small bodied fish in both the Yanco and the broader Murrumbidgee systems. Small fish are important indicators of functioning systems and these play an important role in a healthy and diverse fish community.

The Mid Murrumbidgee River and Yanco Creek are within the range of at least 15 native fish species (Gilligan 2005) and in the mainstem of the Murrumbidgee River there are strong populations of Golden Perch, Silver Perch, Freshwater Catfish, Trout Cod and Murray Cod. There is spawning and self-sustaining populations of the majority of these fish (Baumgartner 2007; Baumgartner and Harris 2007; Jason Thiem, pers. com.).

Trout Cod have been raised as an issue consistently by the local community and are most common in the upper part of Yanco Creek, usually above Tarabah Weir (Sharpe et al. 2013). In Yanco Creek, there is also a Trout Cod population but it is unclear whether these fish form a self-sustaining population or are reliant on spawning in the main stem of the Murrumbidgee system (Sharpe et al. 2013; Sharpe and Stuart 2014).

The Billabong Creek baseline fish survey undertaken in 2013 where 14 species (10 native and 4 exotic) were sampled across 40 survey sites. Non-native Common Carp dominated the biomass (63%). The presence of Trout Cod in Yanco Creek, across a broad spatial range in 2013 (Sharpe et al. 2013) and again in the present 2014 study (albeit with the known distribution extended to Colombo Creek), is however indicative of a persistent and resident population.

Trout Cod are typically rare across the Murray-Darling Basin (Koehn et al. 2014) and Sharpe et al. 2013 suggested that the presence of the species in Yanco/Colombo Creeks indicates that some aspects of the regulated flow regime and existing habitat features are at least somewhat suitable for the species.

Small-bodied fish are also common, as they are elsewhere in the lowlands of the Murrumbidgee River catchment and these include Australian Smelt, Carp Gudgeons, Murray-Darling Rainbowfish, Flatheaded Gudgeons and Unspecked Hardyhead. The very uncommon small-bodied fish include: Southern Purple Spotted Gudgeon, Southern Pygmy Perch, Olive Perchlet and Flatheaded Galaxias, but these are not expected to be present in the Yanco Weir project area.

Low and rising flows are important for upstream migration of native fish species and the fish which can be expected to migrate in the Murrumbidgee and Yanco are identified in Table 3. Fish which can be expected to migrate upstream during high flows, particularly in spring are also shown and the seasonal timing is summarised in Table 4. Although no fish species migrate upstream exclusively on high flows, some fish like Golden Perch, Silver Perch and Murray Cod are highly mobile during floods (100s km).

Downstream migration is also an important component of the life-history of most of the native fish species. Late winter, spring and summer are the important times for upstream and downstream fish movement. The early life stages of fish also drift downstream with Golden Perch, Murray Cod, Trout Cod and potentially Silver Perch eggs and larvae present in spring and summer.

Fish movement to-and-from Yanco Creek is important for the local population ecology and will occur for almost all fish species but especially for freshwater catfish and Trout Cod. The reasons for this movement include for feeding, dispersal, gene flow and re-colonisation.

Within the Yanco Creek, large-bodied fish species (e.g. Murray Cod and Trout Cod) will generally stay in the deeper pools, with strong habitat values and water velocities (i.e. >0.3 m/s). All fish species are more likely to use Yanco Creek in spring and summer rather than winter, unless flow and permanent pools are maintained. There is also likely to be drift of native fish eggs and larvae into Yanco Creek during spring and summer.

The existing Yanco weir structure is a barrier to fish movement. The weir currently has a non-functioning submerged orifice fishway located on the left hand side of the vertical lift gates. This fishway was built in 1980 during the construction of the weir and was based on the European designs which aimed to pass salmonoid fish species. Such designs have since been recognised as ineffective in passing native fish species.

As such, the weir in its current state acts as a barrier to fish passage during flows less than approximately 25,000ML/d. When flows are less than this the weir restricts fish due to excessive head loss, velocity and increased turbulence across the face of the structure. When the vertical lift gates are closed there is no fish passage possible. Similarly, when the gates are partially raised, high water velocities and turbulence experienced through the gates are too great to allow the upstream passage of fish.

Fish passage at Yanco weir may possible less than 4% of the time (dependant on the operation of the gates) in addition, the timing when fish passage is possible may not coincide with spawning migrations of all or any of the resident fish species within the Murrumbidgee River (spring and early summer).

The structure also is not conducive to drift downstream of early life stages of fish. The weir is an undershot weir, which is known to have negative impacts on fish larvae (up to 40% mortality of larvae passing through an undershot weir, compared to only 16% in an overshot weir) (Martin and Graaf 2002: NSW DPI 2006).

**Table 3. The fish community which occurs in the Murrumbidgee River. H=high flow, M=medium flow, L=low flow. \*Unlikely indicates fish species that once occurred in the Murrumbidgee catchment but have not been recorded in the last 20-30 years. # indicates a species with conservation significance. Scale of movement is micro (<100 metres), meso (100s to 10s km) macro (100s km).**

Medium and large-bodied fish CATEGORY 1 & 2	Common name	Murrumbidgee River	Yanco Ck	Usual maximum size	Juvenile migration	Migration river flow	Scale of movement
<i>Macquaria ambigua</i>	Golden perch	✓	✓	600 mm	Yes	H,M,L	macro
<i>Bidyanus bidyanus</i> #	Silver perch	✓	✓	500 mm	Yes	H,M,L	macro
<i>Leipotherapon unicolor</i>	Spangled perch	Unlikely	Unlikely	300 mm	Yes	H,M	macro
<i>Gadopsis marmoratus</i>	River blackfish	Possible	Unlikely	350 mm	Unknown		meso
<i>Maccullochella peelii</i> #	Murray Cod	✓	✓	1200 mm	Yes	H,M,L	macro
<i>Maccullochella macquariensis</i> #	Trout Cod	✓	✓	700 mm	Yes	H,M,L	meso
<i>Tandanus tandanus</i>	Eel-tailed catfish	✓	✓	800 mm	Unknown		meso
<i>Macquaria australasica</i> #	Macquarie perch	Possible	Unlikely	400 mm	Unknown		meso
<i>Anguilla</i> spp.	Freshwater eels	Unlikely	Unlikely	1000 mm	Yes	H,M,L	macro
<i>Mordacia mordax</i>	lamprey	Unlikely	Unlikely	500 mm	Yes	M,L	macro
<i>Nematalosa erebi</i>	Bony herring	✓y	✓	400 mm	Yes	H,M,L	macro
<b>Small-bodied fish (&lt;100 mm long) CATEGORY 3</b>							
<i>Hypseleotris</i> spp	Carp gudgeons	✓	✓	45 mm	Yes	M,L	micro
<i>Craterocephalus stercusmuscarum</i>	Unspecked hardyhead	✓	✓	80 mm	Yes	M,L	micro
<i>Galaxias olidus</i>	Mountain galaxids	Unlikely	Unlikely	100 mm	unknown		meso
<i>Galaxias rostratus</i>	Flat-headed galaxias	Possible	Possible	100 mm	unknown	unknown	meso

<i>Philypnodon grandiceps</i>	Flat-head gudgeon	✓	✓	90 mm	unknown		micro
<i>Philypnodon sp. 1</i>	Dwarf flat-headed gudgeon	✓	✓	50 mm	Unknown		micro
<i>Retropinna semoni</i>	Australian smelt	✓	✓	100 mm	Yes	M,L	micro
<i>Melanotaenia fluviatilis</i>	Murray rainbow fish	✓	✓	90 mm	Yes	M,L	micro
<i>Ambassis agassizii</i> #	Olive perchlet	*Unlikely	*Unlikely	60 mm	Unknown	unknown	micro
<i>Mogurnda adspersa</i> #	Southern purple spotted gudgeon	*Unlikely	*Unlikely	100 mm	Unknown	unknown	micro
<i>Nannoperca australis</i> #	Southern pygmy perch	*Unlikely	*Unlikely	80 mm	Unknown	unknown	micro
<b>Non-native fish CATEGORY 4</b>							
<i>Carassius auratus</i>	Goldfish	✓	✓	300 mm	Yes	M,L	
<i>Cyprinus carpio</i>	Common carp	✓	✓	800 mm	Yes	H,M,L	
<i>Gambusia holbrooki</i>	Gambusia	✓	✓	60 mm	Yes	M,L	
<i>Tinca tinca</i>	tench	Unlikely	Unlikely	400 mm	Unknown		
<i>Perca fluviatus</i>	Redfin perch	✓	✓	400 mm	Yes	M,L	
<i>Salmo trutta</i>	Brown trout	✓	Possible	800 mm	Yes	M,L	
<i>Misgurnus anguillicaudatus</i>	Oriental weatherloach	Possible	Possible	200 mm	Unknown		

Table 4. The timing of fish migrations in the Yanco Weir area of the mid Murrumbidgee River system.

Blue line = upstream movement      Green line = downstream movement.

(Dotted lines Indicate that some movement may occur but data are scarce)

		WINTER	SPRING	SUMMER	AUTUMN
<b>NATIVE</b>					
<b>Large-bodied (500-1000 mm)</b>	Adult		Blue line (Spring), Green line (Spring), Dotted blue (Spring), Dotted green (Spring)		
	Murray cod		Blue line (Spring), Dotted blue (Spring)		
	Larvae		Green line (Spring)		
Trout cod	Adult		Blue line (Spring), Dotted blue (Spring), Green line (Spring), Dotted green (Spring)		
	Juvenile		Dotted blue (Spring), Dotted green (Spring)		
	Larvae		Green line (Spring)		
<b>Medium-bodied (90-500 mm)</b>	Adult		Blue line (Spring), Green line (Spring), Dotted blue (Spring), Dotted green (Spring)		
	Golden perch, silver perch		Blue line (Spring)		
	Larvae		Dotted green (Spring)		
Bony herring	Adult		Blue line (Spring), Dotted blue (Spring)		
	Juvenile		Blue line (Spring)		
	Larvae		Green line (Spring)		
Freshwater catfish, river blackfish, Macquarie perch	Adult		Dotted blue (Spring), Dotted green (Spring)		
	Juvenile		Dotted blue (Spring), Dotted green (Spring)		
	Larvae				
<b>Small-bodied (20-90 mm)</b>	Adult	Blue line (Spring)			
	Australian smelt		Blue line (Spring)		
	Larvae	Green line (Spring)			
Carp gudgeons, flat-headed gudgeon	Adult			Blue line (Summer)	
	Juvenile			Blue line (Summer)	
	Larvae			Green line (Summer)	
Unspecked hardyhead	Adult			Blue line (Summer)	
	Juvenile			Blue line (Summer)	
	Larvae			Green line (Summer)	
Pygmy perch, flat-headed galaxias, olive perchlet, southern purple-spotted gudgeon, dwarf flat-headed gudgeon, Murray hardyhead			Dotted blue (Spring), Dotted green (Spring)		
<b>NON-NATIVE</b>					
Carp	Adult		Blue line (Spring), Dotted blue (Spring), Green line (Spring), Dotted green (Spring)		
	Juvenile		Blue line (Spring), Dotted blue (Spring), Green line (Spring), Dotted green (Spring)		
	Larvae		Blue line (Spring)		
Redfin perch, oriental weatherloach, Eastern gambusia, goldfish			Dotted blue (Spring), Dotted green (Spring)		



## 2.6.2 Macroinvertebrates

Macroinvertebrates form an important component of the aquatic ecosystem, both as part of the natural biodiversity and as a vital component of the food chain (they form the major component of the diets of most native fish).

The major determinants of the abundance and composition of the aquatic macroinvertebrate fauna are the flows, available habitat, sources of food and water quality. In the main, the key habitats for macroinvertebrates in lowland rivers are the benthic sediments, instream vegetation and woody debris in the channel. An additional habitat in lowland rivers is the zone of tree roots along the edge of the channel. These roots provide shelter from high flows and predators, trap leaves and other organic debris in which the macroinvertebrates live.

The major food sources for most macroinvertebrates are algae, biofilms (layers of bacteria and other micro-organisms that cover elements in the water) and terrestrial organic material (leaves, twigs etc) that fall into the stream from the riparian zone.

Altered variability of flows following the construction of dams has been shown to result in reduced aquatic macroinvertebrate diversity downstream of dams (Doeg, 1984; Boon, 1988), high biomass of nuisance biofilms, and reduced diversity of biofilms (Ryder 2004; Watts et al 2008).

Very little is known of the diversity and composition of the macroinvertebrate fauna of the Yanco Creek system. Only one record of a survey, at a single site on the Yanco Creek at Morundah in 1998 could be located. The fauna at that site was typical of lowland rivers, with species associated with snags (e.g. freshwater prawns, beetles and shrimps), aquatic plants (e.g. caddisflies and shrimp), relatively slow-flowing open water (e.g. water bugs) and fine sediments (e.g. freshwater worms). It would seem likely that similar types of communities would be prevalent throughout the remaining parts of the system due to the types of habitats that can be found elsewhere and consistent with the Murrumbidgee river and its wetlands.

Following the environmental flow releases to the Mid Murrumbidgee Wetlands in 2011 it was found the flow had a positive effect by significantly reducing the biomass of biofilm at several sites, most likely due to scouring of biofilms from increased water velocity.

The biofilm was comprised of 58 algal taxa including red algae, green algae, blue-green algae and diatoms. In the Murrumbidgee River, the environmental flow provided benefit by reducing the relative proportion of red, green and blue-green algae and increasing the proportion of diatoms, which are common in unregulated river systems.

For the majority of the dominant macroinvertebrate taxa there was also a short term increase in abundances immediately after the environmental flow.

## 2.6.3 Amphibians and reptiles

Frogs are a key value at all wetlands sites on the Murrumbidgee and Yanco creek. Work undertaken by Charles Sturt University in 2011 recorded frog species at mid-Murrumbidgee wetlands sites prior to the environmental watering (2-5 June 2011), and the surveys after the environmental watering (4-7 July 2011, post-watering 1; and 25 Aug – 2 Sep 2011, post-watering 2).

		Berry Jerry	Narrandera SF	Molleys	Dry Lake	Coonancoocabil	Gooragool	Sunshower	Yarrada	McKinnas	Euroley (C1)	Turkey Flats (C2)	Yanco Ag (C2)
June (prior to watering)	Plains froglet	1										2	1
	Barking marsh frog						2		1				
	Spotted marsh frog											1	
July (post-watering 1)	Plains Froglet	3		1		3	2			3	1		
	Spotted marsh frog								1				
August (post-watering 2)	Plains Froglet	3	8	1	5	3	9	5	4	2	10	23	10
	Spotted marsh frog	2		7	13	1	28	8	9	16	3	21	5
	Peron's tree frog		4			2						2	
	Barking marsh frog								1			1	

The results indicate the obvious ecological response to a watering event, and identify the Plains Froglet, Spotted marsh frog, Peron's tree frog, and Barking marsh frog all being present.

#### 2.6.4 Waterbirds

Waterbirds depend on free-standing water to feed – by swimming, wading or diving – or to establish nesting sites. Inland wetlands also provide important habitat for waterbird species, and at least 34 species depend on wetlands in the Murray-Darling Basin for breeding.

Wetlands provide a variety of habitats and food sources for birds to live and reproduce. Many waterbirds move regularly to newly flooded habitats to feed and/or breed before a wetland dries down. Some semi-permanent, permanent and coastal wetlands can provide refuge for species when wetlands in other regions are dry for long periods. Many species depend on particular wetlands, for refuelling and resting, during their long migrations between wetlands in NSW and other parts of Australia or other countries.

Waterbirds use a range of wetland habitats to source a variety of food. This helps meet the specific dietary needs for different waterbird species, with many being either fish-eaters (piscivores), plant eaters (herbivores), or invertebrate feeders.

Mid Murrumbidgee wetlands with deep, open water attract diving ducks such as musk ducks and hardheads which feed on aquatic plants and animals, particularly yabbies, freshwater shellfish and mussels. Grazing waterfowl such as the Australian wood ducks, black swans and plumed whistling ducks are often found roosting on grassy banks of a wetland or 'bottom up' feeding on wetland plants. Reeds and rushes provide cover for shoreline foragers including crakes, rails and swamphens. Mudflats and shallow water are rich feeding areas for feeders of invertebrates such as spoonbills, ibis, stilts, oystercatchers, dotterels and sandpipers.

The breeding response of many waterbird species has developed in response to the natural flooding regime of inland river systems. The size, timing and duration of flooding and the rate of fall of water levels in a wetland are important factors – either individually or in combination – that influence the success and magnitude of breeding.

In their assessment of significant Murray Darling Basin wetlands, Kingsford et al. (1997) identified the section of the Murrumbidgee floodplain between Wagga Wagga and the Lower Murrumbidgee Floodplain as an important area for waterbirds.

In the 1997 survey Dabbling Ducks (Grey Teal and Pacific Black Ducks) were the most abundant and widespread species, the grazing Australian wood duck was also very common. Of the fish-eating species, little pied and little black cormorants were abundant. Species richness was highest at Sunshower and Gooragool lagoon (15 species) followed by Turkey Flat (13 species).

Briggs and Thornton (1999) showed that the number of nests of waterbirds such as cormorants, herons, egrets, ibis, spoonbills, ducks and teals occurring within the Mid-Murrumbidgee River Wetlands were related to the area and duration of river red gum inundation.

Table 3 provided details of waterbird counts in June, July and August of 2011 across the Mid Murrumbidgee wetlands

Table 5 Waterbird Counts across Mid Murrumbidgee wetlands

	Berry Jerry (n=2)	Narrandera SF(n=2)	Molleys (n=3)	Dry Lake (n=3)	Coonacoocahil (n=2)	Gooragool(n=3)	Sunshower (n=3)	Yarrada(n=3)	Mckennas (n=3)	Euroley (C1)(n=3)	Turkey Flat (C2) (n=3)	Yanco Ag (C2) (n=3)	Total
Australasian grebe	7	1	7		8	3	4	5	5	2	13	4	59
Australasian shoveler											11		11
Australian white ibis			3					3			1		7
Australian wood duck	4		14	6	2	46	143	150	28	8	254	26	681
Black duck					2	1	5			1	2	2	13
Black swan				2			2				5		9
Black-fronted dotterel							5						5
Chestnut teal							7						7
Darter	1			25		28	7		6	1	2		70
Dusky moorhen												9	9
Eurasian coot						2						4	6
Great cormorant				1		27			74				102
Great egret	1		16	10				2		2		2	45
Grey teal	3	3		8	19	47	127	23	54	18	362	34	698
Intermediate egret			5			4	1	5	19				34
Little black cormorant						15		3	42	72			132
Little pied cormorant	84		32	2	5	55	25	20	167	49	3		450
Masked lapwing												2	2
Nankeen night heron			1										1
Pacific black duck		2				41	56	4	6	39	149	13	310

	Berry Jerry (n=2)	Narrandera SF(n=2)	Molleys (n=3)	Dry Lake (n=3)	Coonacocabill (n=2)	Gooragool(n=3)	Sunshower (n=3)	Yarrada(n=3)	McKenna (n=3)	Euroley (C1)(n=3)	Turkey Flat (C2) (n=3)	Yanco Ag (C2) (n=3)	Total
Pied cormorant				1									1
Pink-eared duck						5							5
Straw-necked ibis			23				1	6	13		2		46
White-faced heron	4	4	3			5	6	15	4	2	10	11	66
White-necked heron			15	1		3	8	32			17	2	90
Yellow-billed spoonbill						14	1		1	3		6	25
<b>Grand Total</b>	<b>105</b>	<b>6</b>	<b>111</b>	<b>62</b>	<b>40</b>	<b>303</b>	<b>401</b>	<b>272</b>	<b>420</b>	<b>199</b>	<b>835</b>	<b>117</b>	<b>2918</b>
<b>Total Species</b>	<b>7</b>	<b>3</b>	<b>9</b>	<b>9</b>	<b>4</b>	<b>15</b>	<b>15</b>	<b>12</b>	<b>12</b>	<b>9</b>	<b>13</b>	<b>12</b>	

### 2.6.5 Ecosystem functions

The diverse hydrological environments across the project area perform many ecosystem functions at a local and regional scale. These functions support invertebrates, fish and birds through (but not limited to):

**Food provision through carbon and nutrient cycling** – The hydrological connection between watercourses and their associated floodplain wetlands provides for the exchange of carbon and nutrients (Thoms 2003). During dry periods, organic matter such as leaf litter and grasses, is slowly decomposed by bacteria, releasing carbon and nutrients that accumulate in the soil. On re-wetting, decomposition accelerates and carbon/nutrients are released from the soil where they enter the water and become available for aquatic plants and animals. The release of energy and nutrients results in a very rapid increase in productivity with a proliferation of bacteria and invertebrates. These organisms are food for larger animals and support an increase in their abundance and diversity e.g. frogs, small fish (Ecological Assoc. 2013).

**Transfer of water between the main river channel and floodplain areas** inundates wetlands and billabongs, supplies nutrients and sediments from the river and accelerates the breakdown of organic matter. Any water returning to the river from these areas will provide the main river channel with organic matter (MDBA 2012a). The connections are considered essential for the functioning and integrity of floodplain-river ecosystems (MDBA 2012a). The provision of large woody debris in waterways and wetlands provides a surface for biofilms to establish which then supplies food to aquatic macroinvertebrates.

**Habitat provision and maintenance** – Aquatic vegetation provides shelter, nesting habitat and nesting materials for many aquatic fauna. For example, dense macrophyte beds are important for cryptic waterbirds like Australasian bittern, purple swamp hen and black-tailed native hen. Dense reed beds provide nesting habitat for Southern Bell frog.

As water levels drops, mudflats are exposed which provide conditions for herbland plants to establish. These are then grazed by wading birds such as the great egret (*Ardea alba*), greenshank (*Tringa nebularia*) and the red-necked stint (*Calidris ruficollis*), all of which are listed

under the Japan–Australia, Republic of Korea–Australia and the China–Australia Migratory Bird agreements (MDBA 2012b).

The provision of large woody debris in waterways provides habitat for large bodied native fish and helps contribute to variability in flow velocity and turbulence within anabranch streams. The diversity in velocity, turbulence, width and depth conditions within waterways provides a number of habitat niches that enables the support of several life-stages of native fish – nursery areas, juveniles and adults (NSW Public Works & FCS 2013).

Migration/dispersal/recolonisation – The connectivity between aquatic environments enables the movement of aquatic organisms within and between these systems e.g. longitudinally along waterways and rivers, and laterally between waterways and floodplain environments. This transfer of individuals is required to promote genetic diversity and therefore resilience of populations and communities.

### 3 Proposed works and measures

#### 3.1 Current structures at Yanco offtake

Figure 7 presents the location of the structures currently in operation at the Yanco offtake:

- Existing gated regulator on the Murrumbidgee River (Yanco Regulator)
- Existing (older) fixed crest weir (Yanco Weir)



Figure 7. Location of structures within the site

Yanco Regulator is designed to divert flows into Yanco Creek, in combination with the water level created by Yanco Weir which determines the flow that Yanco Creek receives.

The maximum weir pool level for the existing structure with gates closed is 137.2 m AHD and the commence to flow level for Yanco regulator is approximately 136.1 m AHD. The existing weir pool can only regulate the low flows in Yanco Creek (up to approximately 10,000 ML/d in the Murrumbidgee). Larger flows are shared with the Murrumbidgee River in an uncontrolled way.

The current flow share between the Murrumbidgee and the Yanco Creek system is illustrated in Figure 8.

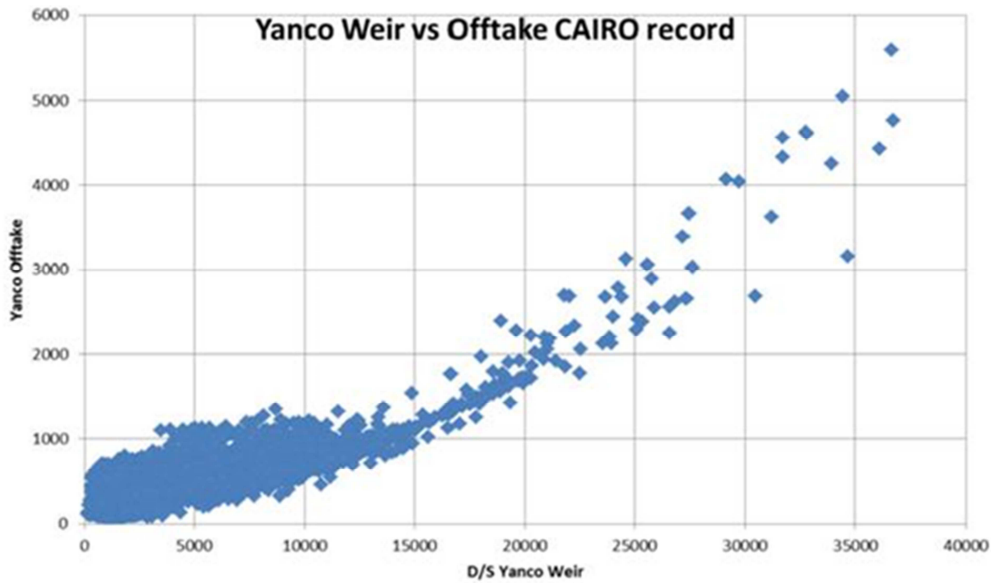

Figure 8. Current relationship between flow in the Murrumbidgee River downstream of Yanco Weir (x-axis) and the flow to Yanco Creek at the Yanco offtake (y-axis)

Details of the existing structures – the 'top gate' Yanco Regulator; and the concretefixed crest Yanco Weir are summarised in [Figure 9](#) and Figure 10 respectively.

Feature	Level
Existing Pool level	RL 137.18
Existing adopted flood level	RL 141.06
Existing gate sill	RL 134.11
Existing Top gate (closed)	RL 137.41
Existing Top Gate (fully open)	RL 146.26
Top Gantry deck	RL 147.81
Existing downstream apron	RL 132.61



Image of the existing Yanco Regulator

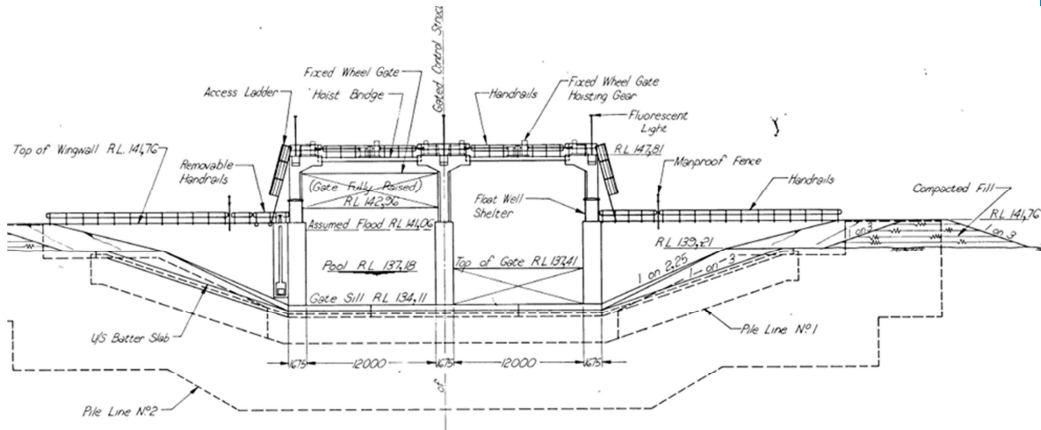

Existing Yanco Regulator design details

Figure 9. Summary of details of the existing Yanco Regulator structure



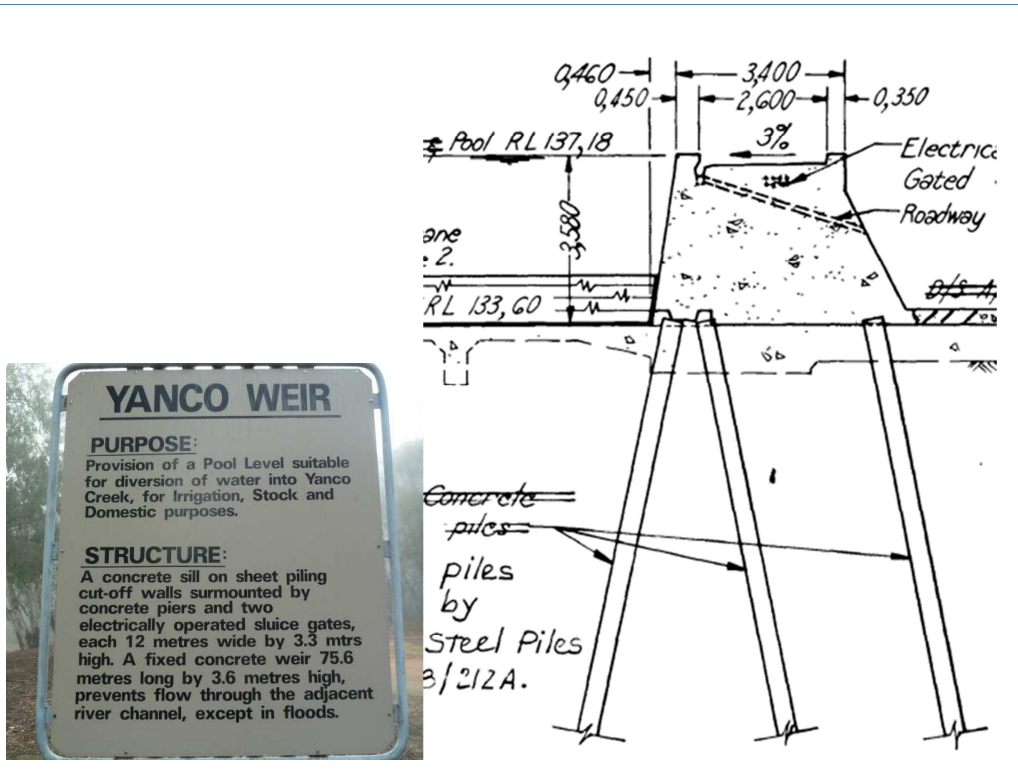

Signage at the existing Yanco Weir

Engineering sketches of the existing Yanco Weir details



Image of the existing Yanco Weir

Figure 10. Existing (older) fixed crest weir

## 3.2 Proposed arrangement

The project comprises the following components with their associated objectives:

- Install a new regulator in Yanco Creek to facilitate more efficient delivery of environmental water to the Murrumbidgee Wetlands. The target environmental flow value, for the purpose of this assessment is 44,000 ML/d at Narrandera. The regulator will mean that the delivered water is not shared with Yanco Creek, which receives about 10% of Murrumbidgee flows in its current unregulated condition.
- Provide infrastructure that will allow the level of the weir pool at the Yanco offtake to be raised to a level such that the flows excluded from the Creek in times of environmental watering of Murrumbidgee wetlands, can be delivered specifically to the Creek at a more appropriate time. This will require changes to the existing arrangements for the Yanco Regulator (on the Murrumbidgee River) and Yanco weir.
- Provide a fishway at the new Yanco Creek Regulator to mitigate the fish barrier that the structure represents
- Provide a fishway at the Yanco Regulator and/or weir as part of the upgrade works

The proposed infrastructure arrangement is shown [Figure 11](#)[Figure 14](#). The main infrastructure components are;

### Yanco Creek Regulator and fishway

A new regulator to be installed in Yanco Creek will utilise a series of overshot gates that will allow downstream fish passage. Upstream fish passage, which is affected by the new structure, will be mitigated with a vertical slot fishway.

The regulator will be designed so that there is minimal change to the Yanco Creek hydraulics when the gates are fully opened.

The regulator will also facilitate the efficient delivery of water demands, both customer and environmental, to locations in the downstream reaches of the Yanco system.

### Increased weir pool level at Yanco weir

The weir pool will be raised at Yanco so that environmental water can be provided to Yanco Creek without having to provide large flows downstream in the Murrumbidgee River. The proposed Yanco Creek regulator will exclude higher flows of well over 4,000ML/d in Yanco Creek when the river is at 44,000ML/d (see Figure 8) or 45,000ML/day considering the flood easement level under constraints program. However its only feasible to raise the weir by 2.5m and this will allow a diversion of about 4,000ML/d into Yanco Creek when river flow is regulated. In addition, the environmental flows recommendations include a requirement for 2,500 ML/d at particular reaches in Yanco Creek. To achieve this it is expected that the weir pool level at the offtake will need to be raised at least by 2.5 metres. The water level at Yanco Weir will retain the bulk of the additional weir pool capacity (~ 2/3) as air space during normal flow periods. However the weir pool capacity will be utilised for:

- delivery of environmental flows to Yanco Creek
- temporary capture and controlled release of local upstream runoff (re-regulation)
- storage of cancelled water orders, pending further supply opportunities.



Figure 11. Arrangement of proposed infrastructure works at the Yanco site

### **New Murrumbidgee Regulator at Yanco Weir**

An investigation of the structural and mechanical capacity of the existing regulator at Yanco weir indicates that it is not suitable for upgrading for the increased water level associated with the new weir pool design level.

Therefore it is proposed to install a new regulator in the meander reach that currently has the Yanco fixed crest weir.

The new regulator will be a four-gated structure – each gate 12 m wide. It will facilitate overshot discharge. The regulator will need to cater for the combined discharge that is currently achieved through the existing two-gate structure and the fixed crest weir.

The regulator will incorporate a vehicle access/bridge to replace the access currently provided on the Yanco weir.

The existing Yanco weir will be retained through the construction period to act as an upstream coffer dam. A downstream coffer dam will be provided by the installation of sheet piles.

### **Fishway at new Murrumbidgee Regulator**

The project will provide for both upstream and downstream fish passage in the Murrumbidgee River at Yanco. To date the structures have represented significant barriers to fish migration in both directions, except during high flow events.

The upstream fish passage will be achieved with a combination of a rock ramp fishway and a vertical slot fishway. The rock ramp will be built against the sheet pile coffer dam installed downstream of the new regulator. An advantage of this approach is that the rock ramp fishway provides a reliable tailwater pool for the regulator, to ensure that downstream passage is viable.

The vertical slot fishway (VSF) will provide for the balance of the fishway 'lift' that will be required to access the weir pool.

### **Upgrade existing Yanco Regulator**

The existing Yanco two-gate regulator will be retained with its existing gates and hoist system. However the sill will be raised by the proposed weir pool increase (2.5 m). The gates will be retained in the closed position except for large unregulated flow events. In that case they will be fully opened to increase overall system capacity.

The structure will need to be upgraded to cater for the increased hydraulic loads associated with a greater water depth. This will involve:

- increasing the height of the sill using mass concrete shaped to allow streamlined discharge through the existing dissipators. It is nevertheless noted that the downstream tailwater will be high at times when the gates are opened.
- installing a series of bored piles through the apron to enhance the factor of safety of the structure.

### 3.2.1 Yanco Creek regulator

The Yanco Creek regulator is a new structure and thus the design can be optimised to the site and flow objectives. The regulator is required to facilitate flows in the Murrumbidgee downstream of the Yanco Weir up to 45,000 ML/d. The gates need to control headwater up to approximately 140.45 m AHD<sup>1</sup>.

The proposed location for the new regulator is in the constructed Yanco Creek cutting, as shown in [Figure 13](#). This site has good access and is approximately 100 metres from the existing control room and power supply at the site.



Figure 12. Proposed site for new regulator

#### Operational protocol

The regulator gate will be retained as a closed, or regulated discharge, gate in the following circumstances:

- (i) Targeted flows to downstream Murrumbidgee River (e.g. environmental flows to Mid Murrumbidgee wetlands) are to be delivered with minimal flows into the Yanco Creek system
- (ii) The weir pool is operated to temporarily store water prior to discharge to downstream Murrumbidgee or Yanco Creek.
- (iii) To manage a flow regime in Yanco Creek

For unregulated flow events in the Murrumbidgee River that are not targeted to downstream of Murrumbidgee River the regulator is to be fully opened.

<sup>1</sup> ref: Hydraulic Modelling and Inundation Mapping for the Murrumbidgee River and Tumut, Beavers, Old Man and Yanco watercourses" undertaken by WaterNSW for Murrumbidgee Constraints Management Study (Murray Darling Basin

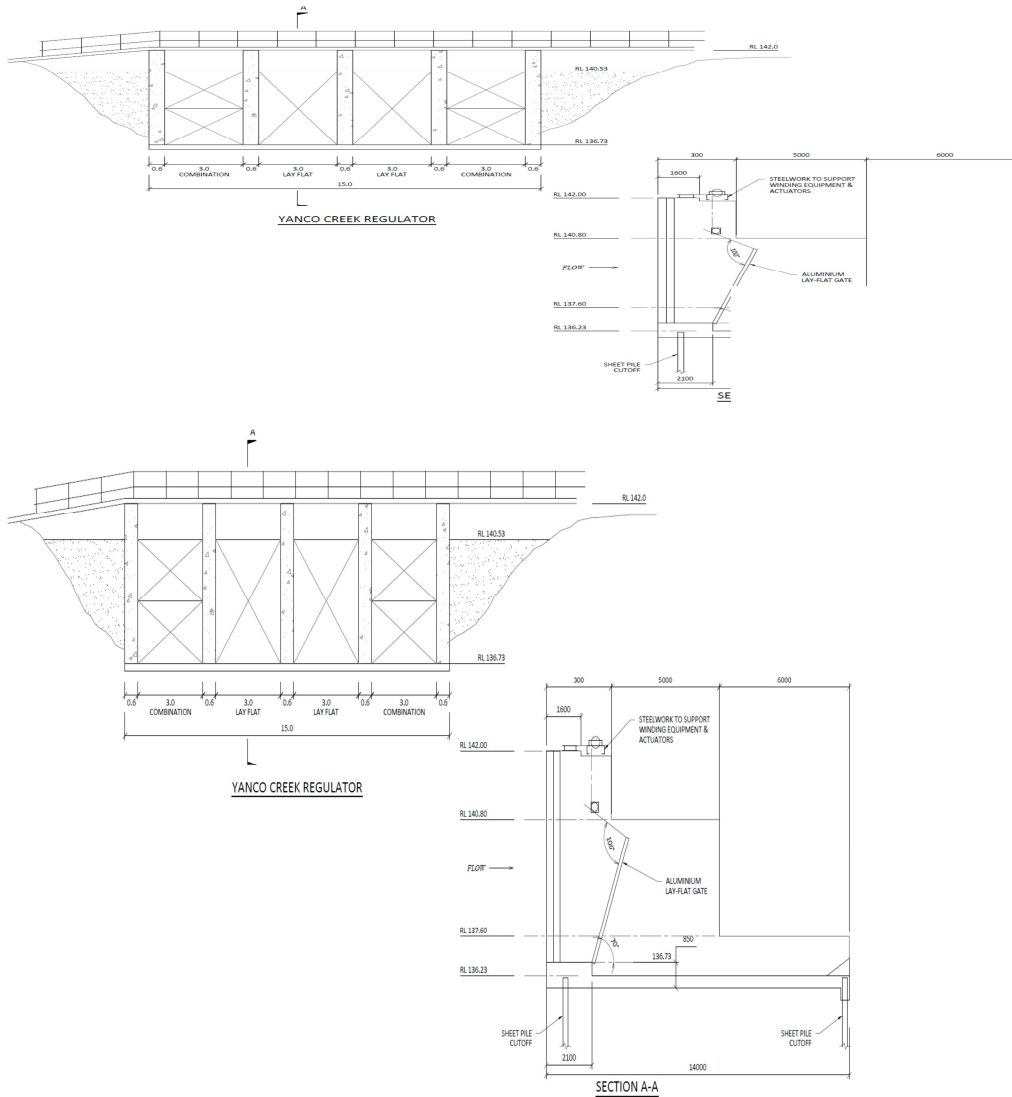

Figure 13. Concept design details for the proposed Yanco Creek regulator

### Gate configuration

The regulator will consist of four 3 m wide gates. It is proposed that the gates be a combination of lay flat gates and combination gates. This will provide the greatest flexibility in flow delivery at the most economical cost. The lay flat gates will be located centrally and will deliver the lower flows.

The capacity of the two lay flat gates is shown in [Figure 14](#), and is compared with the four gates fully open. The tailwater represents the current water level at the site corresponding to the flow rates.

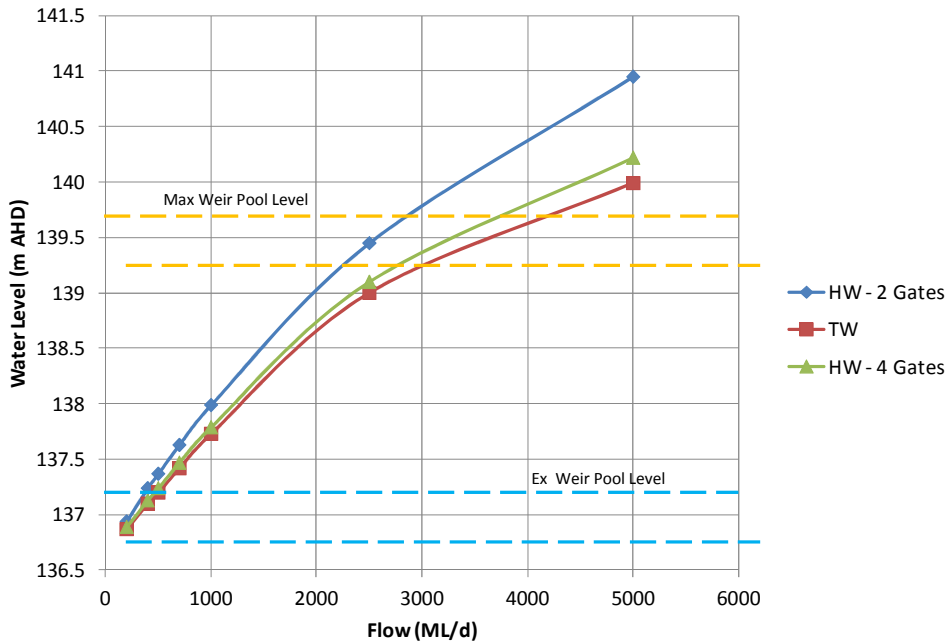

Figure 14. Yanco Creek regulator capacities – Fully Open

The lay flat gates can be operated to regulate flows in Yanco Creek up to the values shown. Lesser flows can be achieved by only partially opening the gate, with the discharge achieved being a function of the difference in level between the weir pool and the lip of the gate.

For periods where the flows in Yanco Creek are to be unregulated, the lay flat gates are fully opened (laid flat) and the combination gates are fully raised, above the weir pool level. The flows through the regulator in Yanco Creek are affected to only a minor degree, as shown by the green line in [Figure 14](#).

The head loss at the gates, when fully opened, is also satisfactory for fish passage through the gates. ([Figure 15](#)).

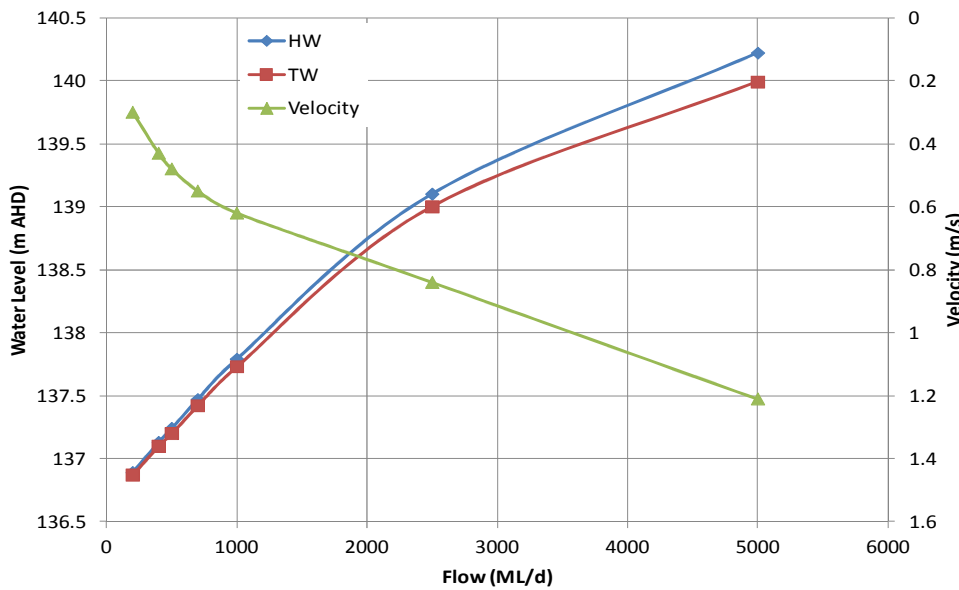

Figure 15. Yanco Creek Regulator showing water levels and velocity

Combination gates are more expensive than vertical penstock gates, but they provide considerably more versatility in operation. They can also be operated as overshot gates when the weir pool is above 138.0 m AHD.

#### Gate height

The target flow in the Murrumbidgee River at the offtake, to deliver environmental water to the mid-Murrumbidgee wetlands, is 45,000 ML/d. The water level at the Yanco offtake corresponding to this is 140.45 m AHD<sup>2</sup>. The invert level at the regulator site is 136.73. Therefore the gates need to be 3.72 m high (4.0 m including freeboard).

#### Hydraulic profiles

The water surface profiles for a range of flows are shown in [Figure 16](#).

Formatted: Font:

<sup>2</sup> ref: Hydraulic Modelling and Inundation Mapping for the Murrumbidgee River and Tumut, Beavers, Old Man and Yanco watercourses" undertaken by WaterNSW for Murrumbidgee Constraints Management Study (Murray Darling Basin



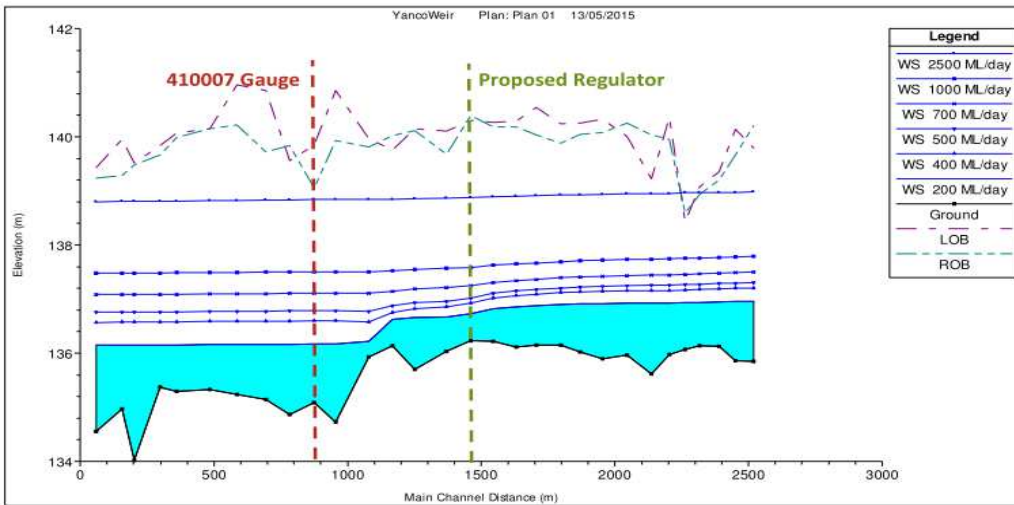

Figure 16. Water surface profiles for Yanco Creek

### Temporary diversion channel

During the construction period it will be necessary to continue to provide flows down Yanco Creek to service demand and base flow. The most practical way to achieve this is to construct a diversion channel on the south side of the existing channel, as shown in [Figure 12](#).

The channel will need to have a similar profile to the existing channel which is estimated at 90 m<sup>3</sup>/m. The length of the channel will be approximately 400 m. Therefore the earthworks required will be approximately 36,000 m<sup>3</sup>. We would recommend that the channel be lined to limit infiltration into the works area.

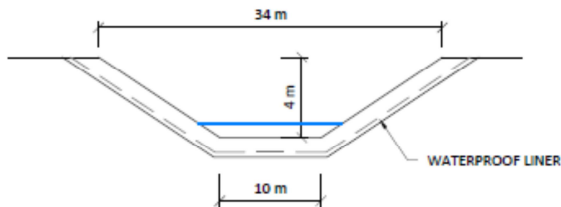

Figure 17. Conceptual cross-section of temporary diversion channel design

### 3.2.2 Fishway at Yanco Creek regulator

The regulator is designed to control a headwater level of 140.45 m AHD. This is the water level associated with a 44,000 ML/d (or 45,000ML/day when considered flooding easement under constraints) flow delivery targeted at the mid Murrumbidgee wetlands, and which the Yanco Creek regulator will exclude from entering Yanco Creek.

At 200 ML/d (base flow) the depth of flow in Yanco Creek is approximately 0.7 m and the water level is 136.9 m AHD.

Therefore the fishway at this site needs to cater for a HW – TW difference of 3.5 m.

We propose that a vertical slot fishway be designed for this site. It will need to be able to accommodate:

- a headwater range from 138.0 to 140.24
- a tailwater range from 136.7 to 137.6

Criteria to be adopted in the design are recommended as follows:

- Cell size ~ 3 m x 2 m
- Hydraulic drop between cells ~ 0.15 m, minimum entrance head loss of 0.1 m
- Minimum water depth of 1.0 m
- average pool turbulence:  $<60 \text{ W/m}^3$  (assuming  $C_d$  of 0.7)
- maximum water velocity (at vena contracta): 1.7 m/s
- fishway slope no greater than 1v:20h
- slot widths should be keyhole and are dependent on detailed design decisions but a 0.3 m slot should be provided for part of the depth (e.g. 0.3 m wide by 0.5 m deep for bottom half and 0.2 m wide by 0.5 m deep for top half)
- fishway entrance to be located at the upstream limit of migration

For maximum 3.55 m HW – TW difference it will require 24 cells, with a drop of 0.15 m between cells. The concept arrangement provides for one entry gate and two exit gates to cater for the range of water levels. The arrangement is presented schematically below, and will be similar to the VSF for the new Yanco regulator on the Murrumbidgee River.

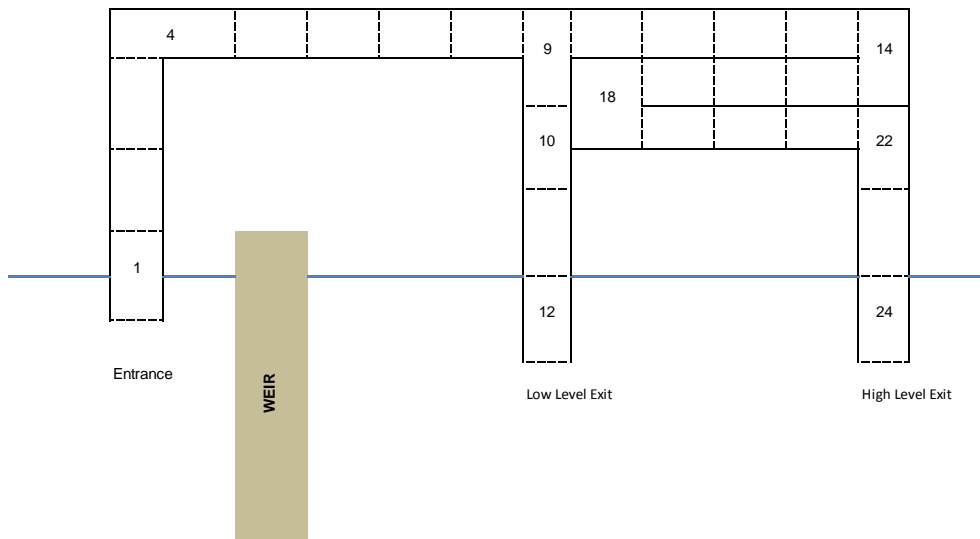

The layout, configuration, and choice of structural materials will be determined in the design development stage. For the purpose of costing we have allowed for a concrete structure. The structure will be set into the right bank. Sheet piling will be employed for shoring to facilitate

construction. Precast concrete units are proposed, but in-situ concrete will also be feasible at similar cost. We have allowed for the system to be fully automated and connected to SCADA. We have also allowed for installation of pit tag readers.

### 3.2.3 New Murrumbidgee Regulator (Yanco weir)

The introduction of the Yanco Creek regulator has the ability to exclude the high flows from Yanco Creek, where these are currently be shared with the creek. To compensate for this the Yanco weir needs to be upgraded so that it will allow the level of the weir pool at the Yanco offtake to be raised to a level such that the flows excluded from the creek in times of environmental watering of Murrumbidgee wetlands, can be delivered specifically to the Yanco Creek system at a more appropriate time.

The new Murrumbidgee Regulator will be located in the same reach as the Yanco Weir as shown in [Figure 18](#).



Figure 18. Location of new regulator in Murrumbidgee River at Yanco

The proposed arrangement is shown in [Figure 19](#).

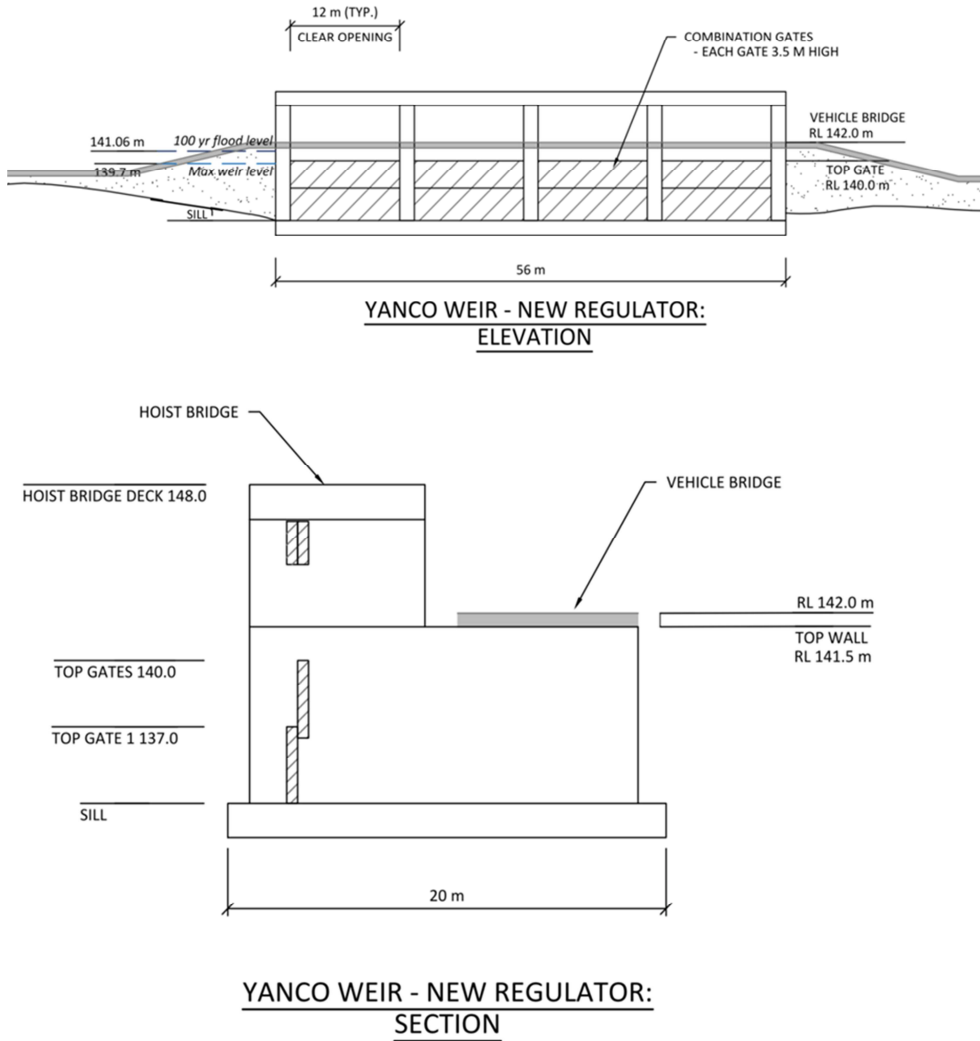

Figure 19. Schematic showing new Murrumbidgee Regulator at Yanco Weir, including approach ramps and access road

The discharge capacity of the proposed four-gate regulator versus headwater level is shown in Figure 20. The chart shows the theoretical discharge capacity for the existing two-gate regulator (fully open) and spill over the fixed crest weir. It also shows the theoretical discharge through the new four-gate regulator to replace the fixed crest weir, plus the existing two-gate regulator with a raised sill. This indicates that the theoretical capacities are reasonably matched.

Hydraulic (MIKE 11) modelling<sup>3</sup> indicate that a lower discharge is achieved than the theoretical discharges at nominated headwater levels. This is likely due to downstream flow constraint issues that are not easily taken into account in the theoretical assessment but can be incorporated into the model.

Nevertheless the chart does indicate that the proposed approach does not impact on discharge capacity at the site.

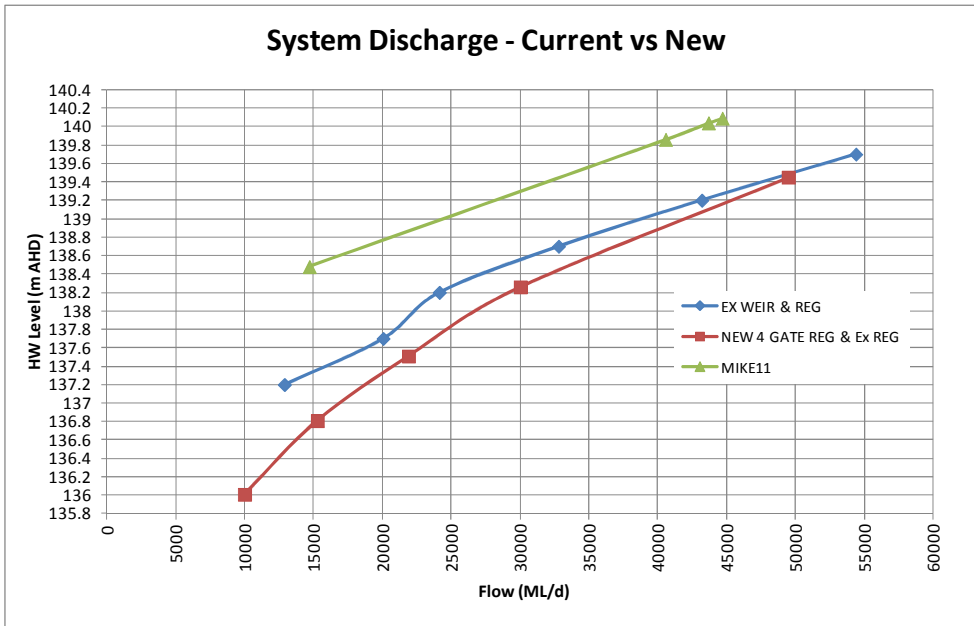

Figure 20. New four-gate regulator – Discharge capacity

At 45,000 ML/d the headwater drop through the structure is approximately 0.5 metres (Figure 21). [Figure 21](#).

<sup>3</sup> Hydraulic Modelling and Inundation Mapping for the Murrumbidgee River and Tumut, Beavers, Old Man and Yanco watercourses" undertaken by WaterNSW for Murrumbidgee Constraints Management Study (Murray Darling Basin).

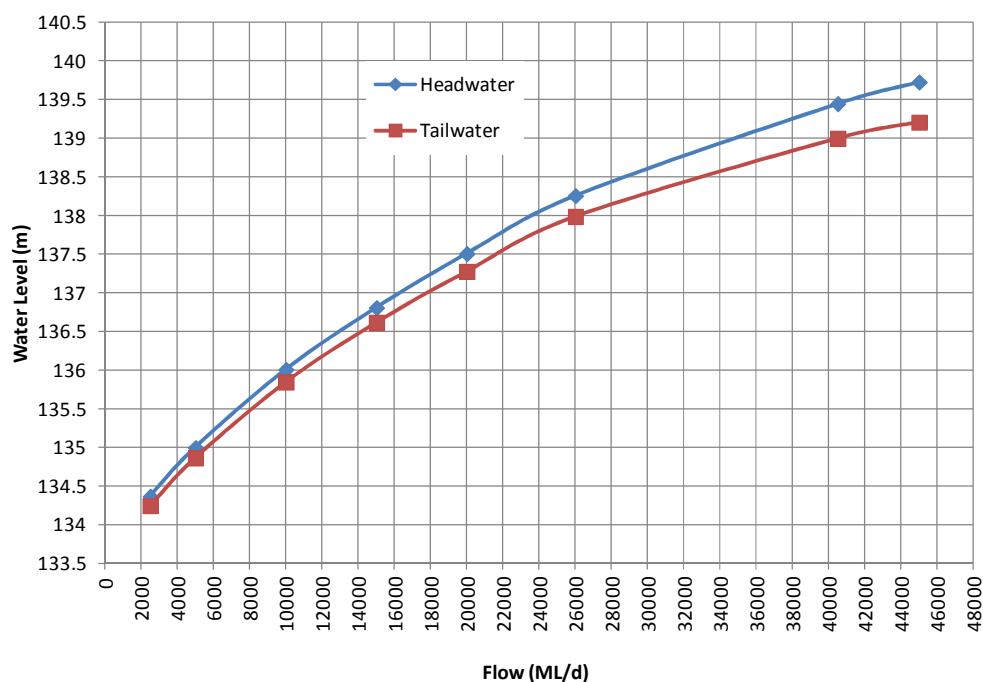

Figure 21. Head loss through new regulator, with all gates fully open

Beyond the design weir pool maximum level there needs to be overspill capacity built into the structure (e.g. fixed crest weir arrangement adjacent to the regulator) so that downstream flood flow capacity in the Murrumbidgee River is not affected.

### Operating arrangements

The weir pool will be maintained, in normal circumstances, at a level in the bottom third of the proposed increase to weir pool level. That is, if the maximum weir pool level were to be increased by 2.5 m the normal weir pool level would correspond with an increase of 0.8 m or less.

The weir pool level will be manipulated in order to regulate flows into Yanco Creek. The purpose is to have the capacity to regulate flows into Yanco Creek to achieve the recommendations of the environmental flows assessment (Alluvium 2013), in particular the higher flows such as overbank, to water the significant floodplain wetland complexes in the system.

Weir pool inundation under the existing and proposed weir arrangement at normal (138.0 mAHD) and maximum (139.68m AHD) weir pool level is shown in Figure 22 to Figure 24.

The weir pool capacity may also be utilised for temporary storage of inflows from local runoff downstream of storages and temporary storage of irrigation orders that have been cancelled after being released from Burrinjuck Dam.

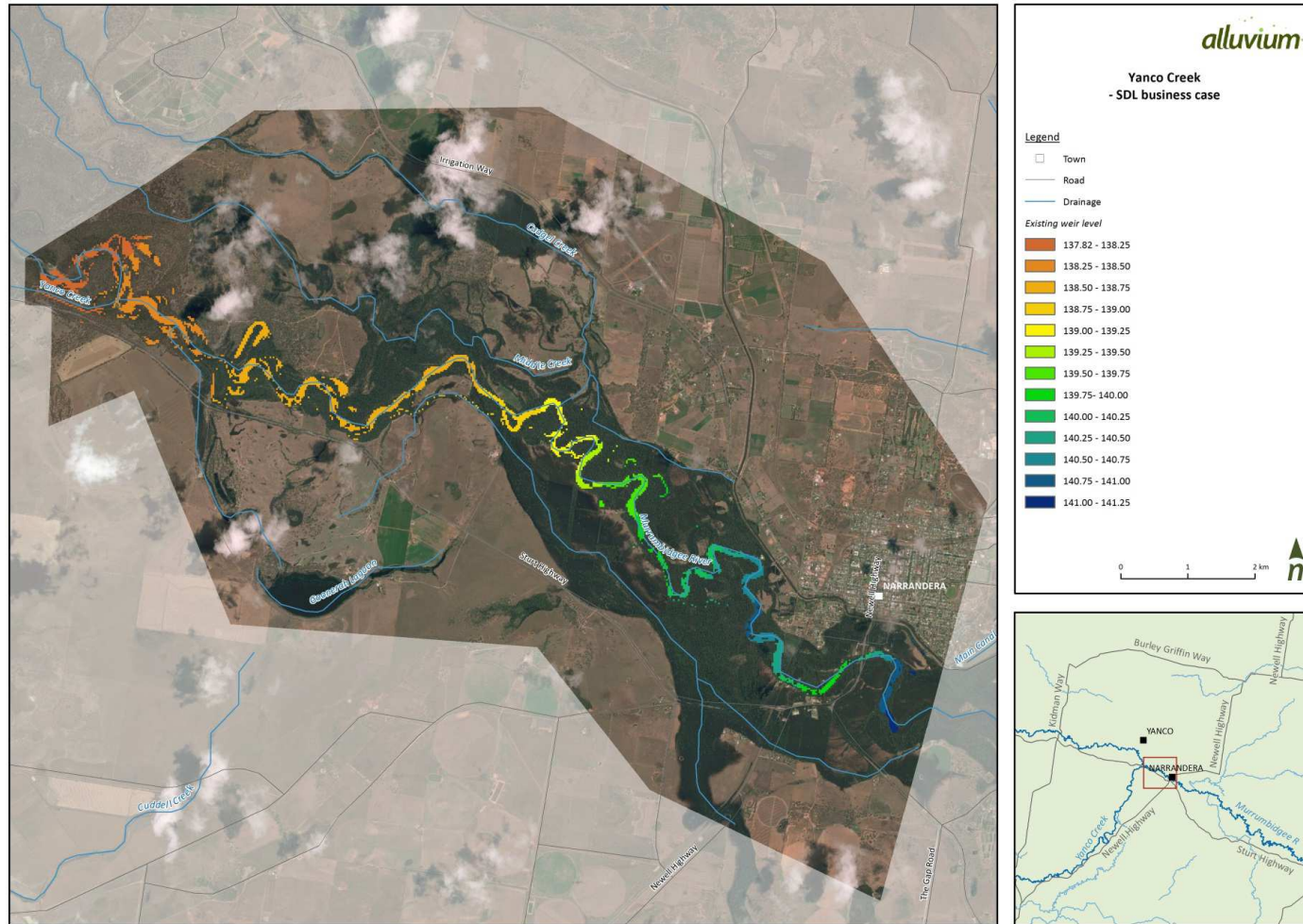

Figure 22. Water depths upstream of Yanco offtake under existing conditions (source: Hydraulic Modelling and Inundation Mapping for the Murrumbidgee River and Tumut, Beavers, Old Man and Yanco watercourses, WaterNSW)

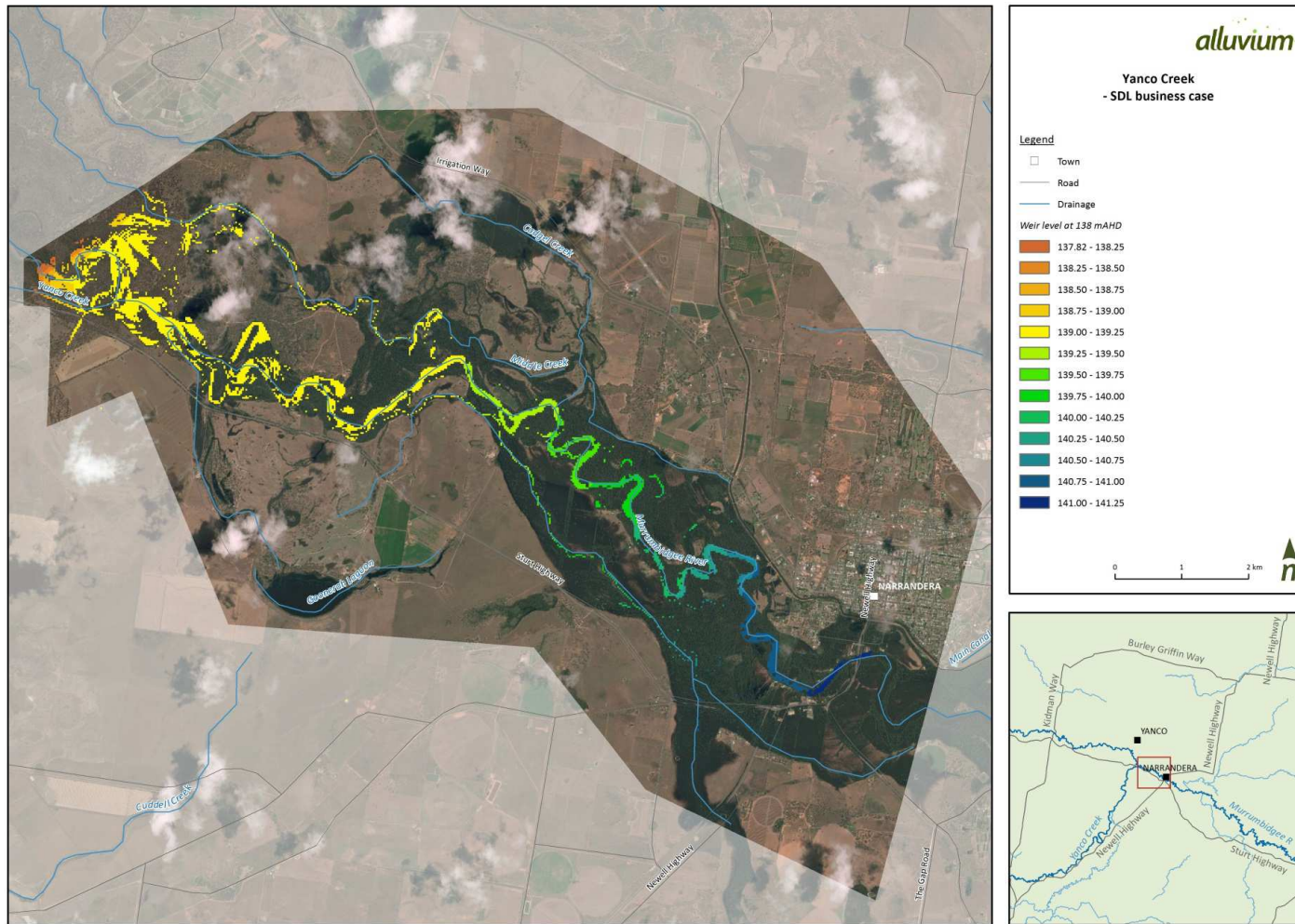
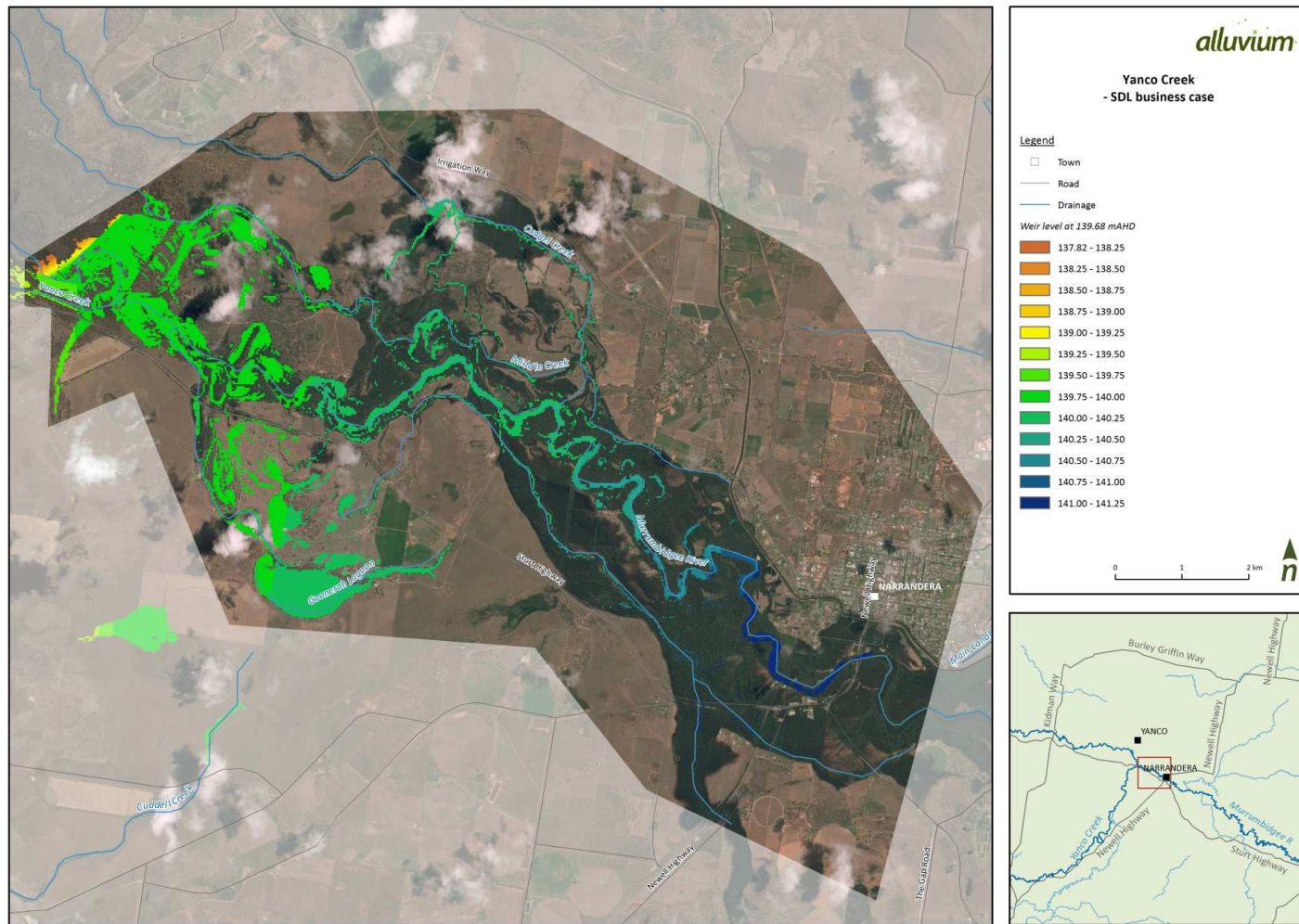

Figure 23. Water depths upstream of Yanco offtake under proposed conditions, weir pool level of 138.0m AHD (source: Hydraulic Modelling and Inundation Mapping for the Murrumbidgee River and Tumut, Beavers, Old Man and Yanco watercourses, State Water Corporation)





### 3.2.4 Fishway at new Murrumbidgee Regulator (Yanco weir)

The fishway will have two components – a rock ramp fishway at the downstream coffer dam site, and a vertical slot fishway at the regulator. The fish ecology model is provided at Appendix 4 of this document. The focus of the upstream fish migration provision is on medium to large fish.

The flow distribution at the gauge downstream of the Yanco Weir (gauge 410 036) is shown in [Figure 25](#). The flow distribution has been filtered to represent the September to March period (when fish passage is important) and does not include flows above 15,000 ML/d (which, in total, represent about 12% of all flows for this period).

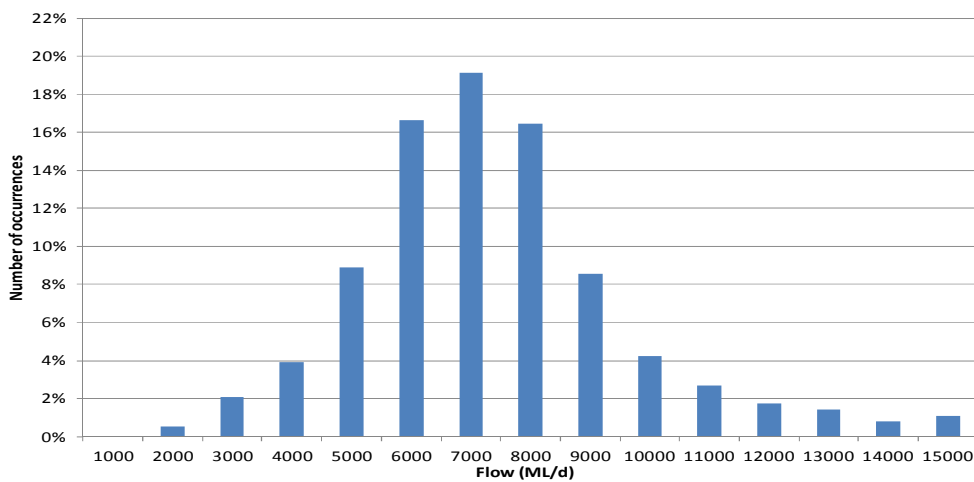

Figure 25. Flow distribution (Sep – Mar) at gauge 410 036 on Murrumbidgee River downstream of Yanco Weir

Flows above 2,500 ML/d represent 98.6% of flows in this September to March period, and have adopted this flow as the minimum design flow for the fishway.

#### Headwater and Tailwater for fishway design

A section in the vicinity of the new weir site is shown in [Figure 26](#).

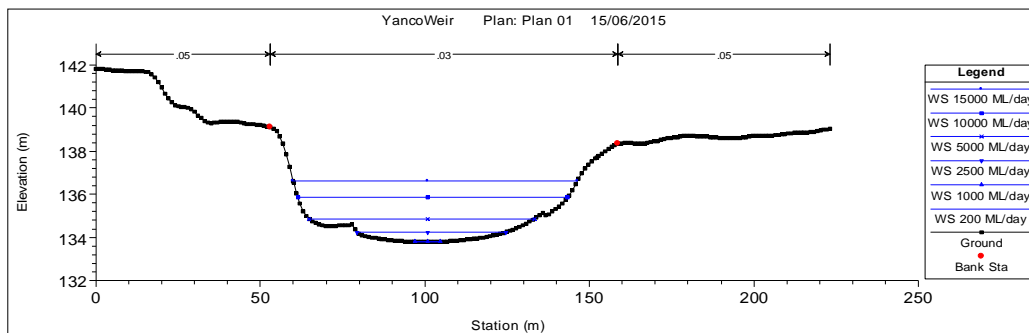

Figure 26. Cross-section downstream of existing Yanco Weir

From this section the tailwater level for a flow of 2,500 ML/d at the site is 134.25 m AHD.

The maximum weir pool level is 139.7 m AHD. The normal operating level for the weir pool will be approximately 138.0 m AHD (i.e. 1/3 of new weir height).

It can be expected that the weir will be operated above the ‘normal’ weir pool level for a few weeks (cumulatively) each year (refer to Section 5.5). The fishway needs to be designed to be operable for the maximum weir pool level to allow fish passage during all events.

Therefore, the maximum headwater-tailwater differential is 5.45 m.

### Fishway arrangement

We propose that the rock ramp fishway be operational for 1m to form the first ‘step’ of the fishway. The vertical slot fishway will be designed for 4.5 m differential head (maximum).

The operating range for the combined fishway is shown below:

	Normal / Low Flow	Maximum / High Flow
Headwater (HW)	138.00	139.70
Tailwater (TW)	134.25	136.60

The maximum headwater-tailwater difference is 5.45 m and the minimum is 1.40 m.

The proposed arrangement for the fishway is shown in [Figure 18](#) ~~Figure 18~~ (Section 3.2.4) and [Figure 27](#) ~~Figure 27~~.

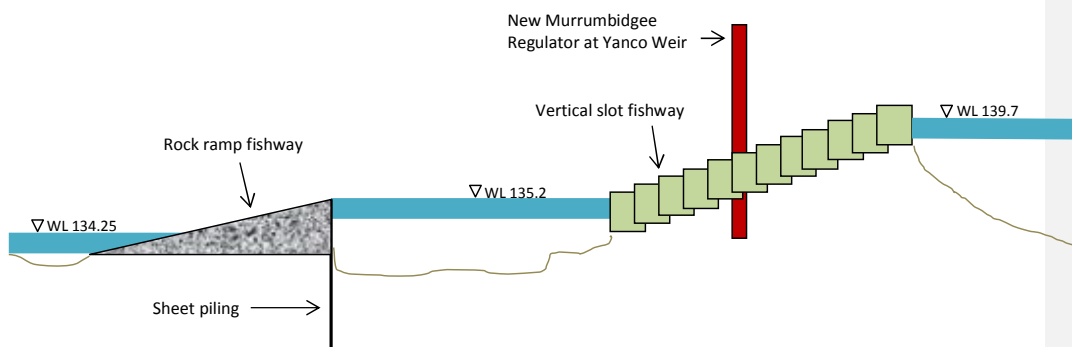

Figure 27. Schematic of two-step fishway

### Rock ramp fishway

The rock ramp fishway has been designed with a full width rock ramp with lateral ridges. Whilst a partial width rock ramp may be suitable, and much cheaper, there is a risk that the entrance may be less reliable. Given the dependence of the upstream vertical slot fishway on the effectiveness of the rock ramp fishway, we consider that this should be a low risk structure.

The rock ramp will have a slope of 1V:30H. The upstream crest will be formed from the steel sheet piles that are used for the coffer dam. The structure will have a shallow V-shape profile that will facilitate fish passage over a range of flows between 2,500 ML/d and 15,000 ML/d. Initial analysis indicates that the rock ramp drowns out at a flow less than 15,000 ML/d.

**Vertical slot fishway**

Criteria to be adopted in the design are recommended as follows:

- Cell size approximately 3 m x 2 m
- Hydraulic drop between cells approximately 0.15 m, minimum entrance head loss of 0.1m
- Minimum water depth of 1.0 m
- Average pool turbulence less than  $60 \text{ W/m}^3$  (assuming  $C_d$  of 0.7)
- Maximum water velocity (at vena contracta): 1.7 m/s
- Fishway slope no greater than 1V:20H
- Slot widths should be keyhole and are dependent on detailed design decisions but a 0.3m slot should be provided for part of the depth, e.g. 0.3 m wide by 0.5 m deep for bottom half and 0.2 m wide by 0.5 m deep for top half.
- Fishway entrance to be located at the upstream limit of migration

Tailwater range will be 135.2 (low flow) to 136.6 (15,000 ML/d), or 1.4 m. Headwater range is 139.7 (maximum new weir pool) to 137.0 (current weir pool providing base flow to Yanco Creek), or 2.7 m.

Based on the design criteria and operating ranges, the proposed arrangement has one entry gate and two exit gates to cater for the range of water levels. The max HW – TW range is 4.5 m. With 0.15 m drops in each cell, 30 cells will be required. A concept arrangement is shown in Figure 28.

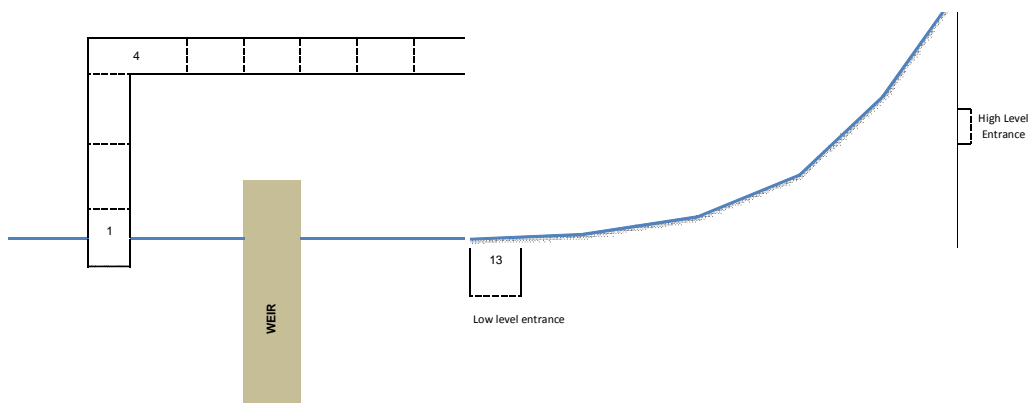

Figure 28. Concept arrangement for vertical slot fishway at the new Murrumbidgee River regulator

**Design and cost**

The layout, configuration, and choice of structural materials will be determined in the design development stage. For the purpose of costing we have allowed for a concrete structure with one entry gate and two exit gates to cater for the range of water levels. The structure will be set into the right bank. Sheet piling will be employed for shoring to facilitate construction. Precast concrete units are proposed but in-situ concrete will also be feasible at similar cost. We have allowed for the system to be fully automated and connected to SCADA. We have also allowed for installation of pit tag readers.

### 3.2.5 Upgrade existing Yanco Regulator

The existing Yanco Regulator requires an upgrade to be suitable for the increased weir pool level. This will involve:

- increasing the height of the sill using mass concrete shaped to allow streamlined discharge through the existing dissipators. It is nevertheless noted that the downstream tailwater will be high at times when the gates are opened.
- installing a series of bored piles through the apron to enhance the factor of safety of the structure.
- Downstream rock protection of apron

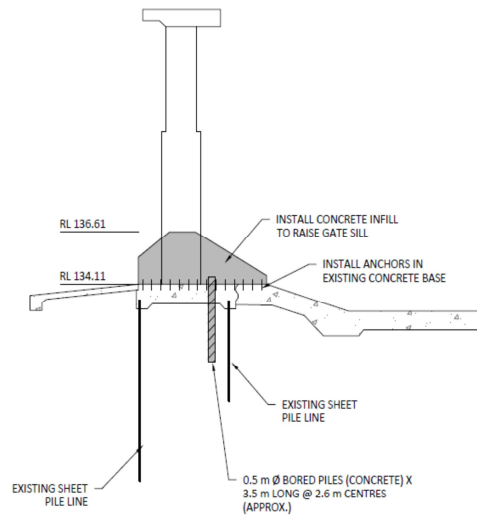

Figure 29. Proposed upgrade to arrangement at Yanco Regulator

### 3.3 Proposed infrastructure rules and hydrology

The proposed works have been designed to efficiently supply water to the Mid Murrumbidgee wetlands while minimising changes to the flow regime down the Yanco Creek system. The development of the operational rules are a key part of the management of the structures, and will be agreed through the 'works approval' process led by NSW DPI Water (further information on process in Sections 5.7 and 8).

The operating rules outlined below are those proposed by WaterNSW. These rules have been modelled in the Murrumbidgee IQQM. Outcomes of this hydrological modelling are discussed in Sections 4 and 5.

### 3.3.1 Proposed operating rules

#### Rule 1- Regulated flows into Yanco Creek

For flows less than 15,000 ML/d in the Murrumbidgee River at Narrandera, regulate the flows between the Murrumbidgee and Yanco system to meet the orders. (i.e. Operate Yanco Creek regulator to supply flows into Yanco Creek system to meet the orders including minimum flow requirements along the Yanco Creek system). WaterNSW will operate the regulator to deliver the same flow regime for flows below 15,000 ML/d that occurred under current operational arrangements.

When Murrumbidgee River is above 15,000 ML/d, operate Yanco Creek regulator to divert a minimum of 600 ML/d into Yanco Creek to maintain base flow and fresh events.

#### Rule 2 – Targeted Environmental flows into Yanco Creek

Rule 2 is applied in addition to Rule 1. Between September and December when unregulated flow in the Murrumbidgee River is between 10,000ML/d and 24,000ML/d, the hydrograph is receding, and sufficient surplus flows exist:

- divert up to 1,500 ML/d into Yanco Creek, on top of flow for rule 1 and any orders, for up to 3 days once a year
- divert up to 2,500 ML/d into Yanco Creek ,on top of flow from rule 1 and any orders, for up to 5 days on average every second year.

Between August and December when unregulated flow in the Murrumbidgee is between 10,000ML/d and 24,000ML/d, the hydrograph is receding, and sufficient surplus flows exist:

- divert up to 4,000ML/d into Yanco Creek, on top of flow from rule 1 and any orders, for up to 5 days if there is a flow (up to bankfull) occurring in the unregulated portion of Billabong Creek, on average every 3 years.

Between January and April when unregulated flow in the Murrumbidgee is between 10,000ML/d and 24,000ML/d, the hydrograph is receding, and sufficient surplus flows exist:

- divert up to 4000ML/d into Yanco Creek, on top of flow from rule 1 and any orders, for up to 5 days.

#### Rule 3 - Targeted Environmental flows to Mid Murrumbidgee Wetlands

When flows exceed 24,000 ML/d in the Murrumbidgee River, Yanco Creek regulator is managed to deliver orders.

**Note:** Control of flows delivered to the Yanco Creek system is exceeded when flows are in excess of 45,000 ML/d in the Murrumbidgee River.

### 3.4 Costs

The works proposed for the proposed works and measures are presented in ~~Table 6~~ Table 6 and described in more detail in the following sections. Taken together, the proposed construction costs involve a total investment of \$50.5 million + GST. This costing comprises [REDACTED] construction costs and a further [REDACTED] in project management costs.

**Formatted:** Font: (Default) Arial, 11 pt, Not Bold, Font color: Auto

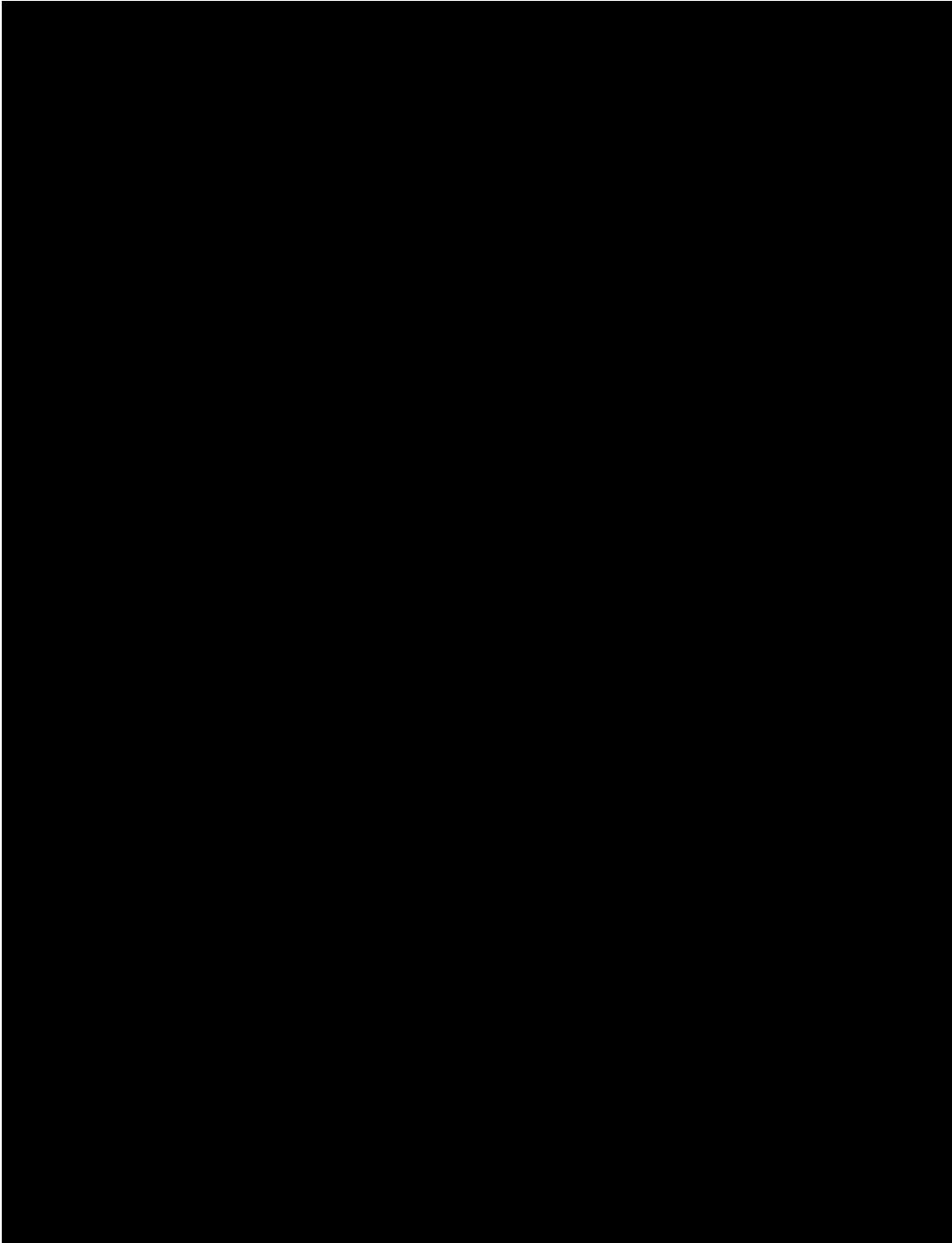

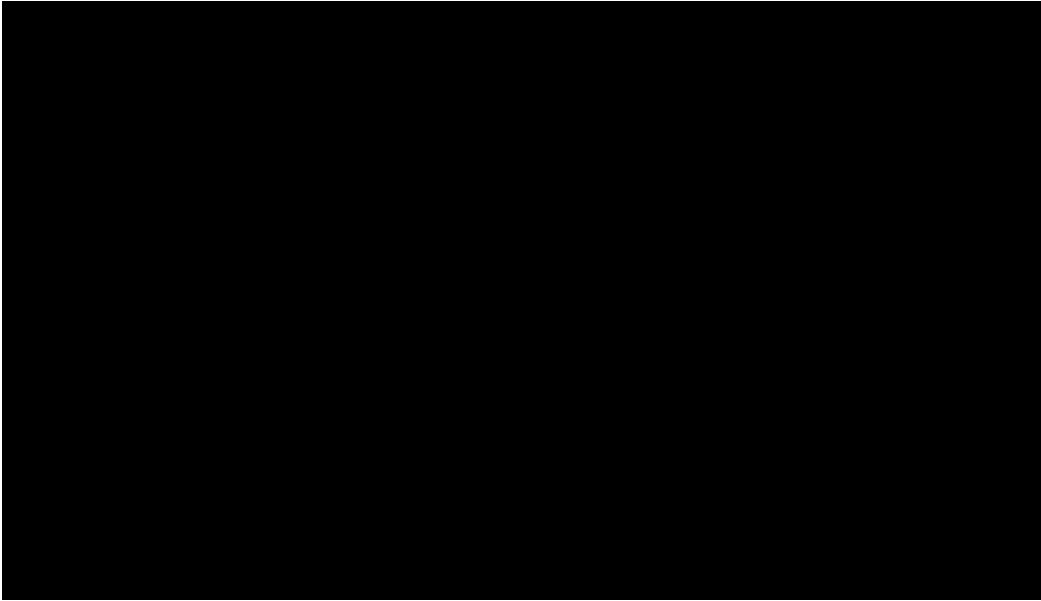



## 4 Anticipated outcomes

### 4.1 Anticipated ecological outcomes

#### 4.1.1 Fish

The environment present within the Mid Murrumbidgee River Wetlands has been identified as supporting native fish (Morris et al 2001, Gillian 2005). The site supports important habitat and species that are listed in international agreements, and include vulnerable and endangered species such as Murray Cod (*Maccullochella peelii peelii*). Achieving the targets for floodplain wetlands and water birds will ensure inundation of breeding and feeding habitats considered key for a range of fish, amphibian and water-dependent reptile and invertebrate species (MDBA Publication No: 35/12).

Improved watering outcomes to the Mid Murrumbidgee wetlands would likely result in greater fish numbers. In the Wassens (2012) report which reviewed post environmental flow releases the environmental release appeared to favour native over exotic species, and native fish were more abundant in filled wetlands than introduced species. Juveniles of all five native species were recorded in filled wetlands, with juveniles of carp gudgeon, bony bream and un-specked hardyhead making up 50% or more of the total catch for these species by February 2012.

Wassens (2012) reviewed changes in fish communities over time in the Mid Murrumbidgee wetlands and noted that three native species (un-specked hardyheads, Murray-Darling rainbow fish and bony bream) were not recorded during surveys in August 2011 but were likely to have recolonised wetlands during subsequent top-up flows in September 2011 (natural event) and December 2011 (environmental release).

The increased flow outcomes of this proposal are likely to result in a more frequent recolonization of semi permanent wetlands by native fish.

Installation of weir structure or raising of current weir heights would increase water ponding, changing the hydrological dynamics. This in turn may have a detrimental impact on fish which live in fast flowing conditions (refer Section 5).

Achieving the targets for floodplain wetlands and waterbirds will ensure inundation of breeding and feeding habitats considered key for a range of fish, amphibian and water-dependent reptile and invertebrate species

#### 4.1.2 Frogs and Amphibians

Wassens (2012) identified that five species of frogs were recorded in the Mid Murrumbidgee Wetlands from June 2011 to February 2012. Four species, the plains froglet *Crinia parinsignifera*, Perons tree frog *Litoria peronii*, barking marsh frog *Limnodynastes fletcheri* and spotted marsh frog *Limnodynastes tasmaniensis*, were widespread, however the inland banjo frog *Limnodynastes interioris* was restricted to a single site.

It was noted that the southern bell frog *Litoria raniformis* had been previously been recorded in November 2010, but not found again during the 2011 – 2012 surveys.

The abundance of frogs in wetlands that received water during the 2011-12 environmental releases was generally higher than areas which did not receive water as part of the environmental release, but the outcomes did differ among species. The abundance of barking

and spotted marsh frogs increased significantly within wetlands that received environmental water in 2011-12, but the abundance of Peron's tree frogs and plains froglet did not differ significantly in response to the environmental flow.

The increased flow outcomes of this proposal are likely to result in a more frequent recolonization of semi-permanent wetlands by native fish.

Improved watering outcomes to the Mid Murrumbidgee wetlands would result in greater recruitment for wetland frog species (particularly barking and spotted marsh frogs) leading to an increased abundance of frogs within filled wetlands. It is possible that an improved watering outcome would also facilitate the recruitment of the Southern Bell Frog.

#### **4.1.3 Water birds**

Studies by Briggs et al. (1997), Briggs et al. (1994), Briggs and Thornton (1999) and Kingsford et al. (1997) have shown that the mid-Murrumbidgee is an important area for waterbirds including breeding of colonial nesting waterbirds. (MDBA Publication No: 35/12). Improved watering outcomes to the Mid Murrumbidgee wetlands will increase foraging opportunities, promote nesting and create conditions for the successful fledging of birds.

Survey data has showed that waterbird communities were diverse in the filled mid-Murrumbidgee wetlands with 36 species recorded during the 2011-12 surveys (Wassens (2012). During this assessment, two species listed on international bird agreements were observed and breeding activity was detected in eight species. None of the observed species are listed on the NSW *Threatened Species Conservation (TSC) Act 1995* or the Commonwealth *EPBC 1999 Act*. The populations of waterbirds were highly correlated to the presence of water in the wetlands.

Briggs and Thornton (1999) showed that the number of nests of waterbirds such as cormorants, herons, egrets, ibis, spoonbills, ducks and teals occurring within the Mid-Murrumbidgee River Wetlands were related to the area and duration of river red gum inundation. To enable waterbirds to complete breeding and fledge their young, river red gums need to be inundated for at least 5 and up to 10 months (Briggs and Thornton 1999). These authors also recommended that river red gum wetlands should be flooded in winter/spring with flows from the river.

The MDBA produced a table to describe the significant bird breeding wetlands and some key wetland characteristics. Summarising the outcomes to achieve intended bird breeding outcomes a flow rate of 47,000 (commence to flow (ML/d) is required at Wagga (27,000 ML/d at Narrandra). The observed flows during the period July 1988 to June 1994 indicate that rates exceeding 27,000 ML/d for a total of around 45 days will inundate river red gums at the surveyed sites for at least 5 and up to 10 months, and provide sufficient duration of inundation to achieve successful bird breeding outcomes. (MDBA Publication No: 35/12)

#### **4.1.4 Aquatic vegetation**

The Mid Murrumbidgee wetlands did significantly suffer through the millennium drought and slow recovery of the aquatic vegetation in the mid-Murrumbidgee wetlands is an important consideration (MDBA 2014). The clearest example of slow recovery of aquatic vegetation following prolonged drying was at McKennas lagoon which was dry for eight years, but which historically supported dense stands of tall spike rush *Eleocharis sphacelata* and had a very high percent cover of aquatic vegetation. After eight years without water the aquatic vegetation communities did not recover following the environmental releases to the same extent as those wetlands which had been dry for between three and five years. Tall spike rush which was

abundant at McKennas Lagoon in 2001 was not recorded at all during our surveys in 2010-12 (Wassens 2012)

The long-term persistence of aquatic vegetation is dependent on the maintenance of a viable seed bank. The seed bank can be affected by dry period where the viability of seed declines over time with seed banks progressively depleting if the wetland remains dry for longer than about six years (Roberts and Marston 2011). Seed banks are also influenced by watering and the hydrologic pathways for dispersal of seeds and propagules (Roberts and Marston 2011), for instance connectivity by floodwater facilitates dispersal and re-colonisation of wetlands by aquatic species (Sheldon et al. 2002).

Improved watering outcomes would result in further and more frequent connection of the wetlands with the Murrumbidgee River and will increase the likelihood of aquatic vegetation recovery, improving seed banks and ultimately improving the resilience of aquatic vegetation in the Murrumbidgee Valley.

#### 4.1.5 Riparian and terrestrial vegetation

Terrestrial vegetation of the Mid-Murrumbidgee River Wetlands is dominated by river red gum (*Eucalyptus camaldulensis*) which forms a continuous band along the river. In the lower section of the mid-Murrumbidgee floodplain system black box woodlands (*E. largiflorens*) become a common feature on higher ground away from the river. Lagoons and swamps occur along the river and fill from high flows. (MDBA Publication No: 35/12)

River Red Gum normally occurs on cracking clay soils along drainage lines and low floodplain. Black Box normally occur on grey clay soils along drainage lines and in depressions on the low and mid-floodplain. They often have variable understorey ranging from flood-dependent wetland species to flood-tolerant chenopods. .

The primary driver delivering environmental flows to River Red Gum and Black Box communities are to improve vegetation health and vigour which in turn has ecological benefits to water birds in particular.

Overton et.al. 2014 indicates that associated waterbird ecological elements for improving the health of these flora communities includes:

River Red Gum	Black Box
Bitterns, crakes and rails	Bitterns, crakes and rails
General abundance and health – all waterbirds	General abundance and health – all waterbirds
Breeding – Colonial-nesting waterbirds	
Breeding – other waterbirds	

Red Gum Forests require a maximum inundation of 75 out 100 years and a minimum of 33 out of 100 years (optimal inundation 70 out of 100 years) and with a minimum duration of 5 months and maximum of 7 months. Black Box woodlands require a maximum inundation of 33 out 100 years and a minimum of 14 out of 100 years (optimal inundation 25 out of 100 years) and with a minimum duration of 2 months and maximum of 3 months.

Improved watering outcomes aligned with the regimes presented above would result in a greater extent of inundation of River Red Gum and Black Box vegetation communities. This in turn has flow on benefits to birds and other fauna.

#### 4.1.6 Macroinvertebrates

Increased flow events have the most beneficial impact on instream biofilms and macroinvertebrates. Environmental flows in the Murrumbidgee significantly reduced the biomass of biofilm, most likely due to scouring of biofilms from increased water velocity. The benefits to instream ecosystem due to reduced biomass of biofilms is an increase in the relative proportion of early successional algal taxa (e.g. diatoms) and increased number of macroinvertebrate taxa.

In addition, the composition of biofilms changed following the environmental release with reduced relative proportion of red, green and blue-green algae and increased diatoms. These positive changes were maintained within the Murrumbidgee for an extended period after the release.

Improved watering outcomes aligned with increase flow releases would result in reduced biomass of biofilm and algae and increased successional algal taxa (e.g. diatoms) and number of macroinvertebrate taxa.

## 4.2 Achievement of objectives and targets

### 4.2.1 Achievement of specific flow indicators - Mid Murrumbidgee wetlands

Section 2.5.1 identified that the environmental water requirements of the Mid Murrumbidgee Floodplain Wetlands have been evaluated and quantified through the development of five site-specific flow indicators (SFIs), and outlined how the focus of this proposal is to target delivery of the SFIs ranging from 26,850 to 45,000 ML/d in the Murrumbidgee River at Narrandera, namely:

- 26,850 ML/d for a total duration of 45 days between July & November for 20% of years
- 26,850 ML/d for 5 consecutive days between June & November for 50% of years
- 34,650 ML/d for 5 consecutive days between June & November for 35% of years
- 44,000 ML/d for 3 consecutive days between June & November for 30% of years

The target magnitude, frequency and duration of the SFIs in the Murrumbidgee River and Narrandera were derived by the MDBA based upon hydraulic modelling which estimated the extent of inundation of the Mid Murrumbidgee Floodplain Wetlands for each SFI event. In essence, the magnitude and duration of SFI events was derived to achieve a target level of inundation of the Mid Murrumbidgee Floodplain Wetlands. Importantly, the hydraulic modelling which informed the development of these SFIs was based upon operation of the Yanco Creek regulator as per the benchmark conditions.

This SDL adjustment proposal to modify the operating conditions of the Yanco Creek regulator will alter the extent of inundation of the Mid Murrumbidgee Floodplain Wetlands for a given flow rate in the in the Murrumbidgee River at Narrandera. WaterNSW have undertaken hydraulic modelling to examine the change in inundation extent arising from the proposed operation of the Yanco Creek regulator. From their hydraulic modelling, WaterNSW estimated what flow magnitude in the Murrumbidgee River at Narrandera would provide equivalent inundation of the Mid Murrumbidgee Floodplain Wetlands as that which occurred under each site-specific flow indicator (Table 7). Their results demonstrate that implementation of the proposal will allow the desired extent of Mid Murrumbidgee Floodplain Wetland inundation to be achieved with flow rates in the Murrumbidgee River (at Narrandera) that are 8 – 9% less than the flow rate required under the benchmark.

By inference, the proposal will therefore lead to a given flow event (e.g. an SFI) providing increased inundation of the Mid Murrumbidgee Floodplain Wetlands than occurs under the benchmark.

**Table 7. Equivalent flows in the Murrumbidgee River at Narrandera to achieve the equivalent inundation of Mid Murrumbidgee Floodplain Wetlands as the benchmark for each SFI. Source: WaterNSW**

Yanco Creek regulator operated as per benchmark	Yanco Creek regulator operated as per proposal	Change in Murrumbidgee River flow to achieve equivalent inundation
26,850 ML/d	24,621 ML/d	- 8.3%
34,650 ML/d	31,522 ML/d	- 9.0%
44,000 ML/d	39,912 ML/d	- 9.3%

Schedule 6 (Section S6.07) of the Basin Plan uses SFIs to define the limits of acceptable change in outcome from the benchmark to environmental outcomes (i.e. those achieved by the unadjusted SDL) to the proposed outcomes. These limits of acceptable change ensure environmental outcomes are maintained within identified limits. The limits of acceptable change in the provision of SFIs are as follows:

- Where the benchmark model run achieves or exceeds the target frequency range for a SFI, achievement of the target frequency range must be retained and the frequency result must not vary by more than 10% of the benchmark result
- Where the benchmark model run does not achieve the target frequency range for a SFI, the frequency result must not vary by more than 10% of the benchmark result, and not fall below the baseline model result
- Where the benchmark model run provides little improvement in frequency for a SFI (less than 50% progress toward the target range from the baseline model result), the frequency result must not vary by more than 15% of the benchmark result, and not fall below the baseline model result
- Where a supply measure or combination of measures can achieve the ecological outcomes sought by the plan as represented by an ecological target or targets, and SFI(s) and associated benchmark model results, then the three dot points above do not apply to that SFI(s).

Table 8 examines the change in the achievement of the SFIs for the Mid Murrumbidgee Floodplain Wetlands, Lower Murrumbidgee Floodplain Wetlands, and lower Murrumbidgee River under the proposal, relative to the benchmark conditions. This table shows the percentage of years that each target SFI is achieved in full (green header), is partially achieved (orange header), and either fully or partially achieved (blue header). For the SFIs corresponding to the Mid Murrumbidgee Floodplain Wetlands, the results are provided for both the:

- unadjusted flow rate - the flow rate in the Murrumbidgee River at Narrandera that provides the desired inundation extent with Yanco Creek regulator operated under benchmark conditions e.g. 26,850 ML/d
- adjusted flow rate – the flow rate in the Murrumbidgee River at Narrandera that provides the desired inundation extent with Yanco Creek regulator operated under proposed conditions e.g. 24,621 ML/d.

The results demonstrate that the proposal provides a major improvement in the achievement of all SFI events for the Mid Murrumbidgee Floodplain Wetlands, when the effect of the greater inundation for a given flow rate is accounted for – refer results for the ‘adjusted flow rate’. The impact of the proposal is most significant for the 44,000 ML/d SFI event, which sees the percentage of years with successful events increase from 27% to 35%, rising to 44% when partially successful events are also accounted for. Across all SFIs for the Mid Murrumbidgee Floodplain Wetlands, the proposal results the number of successful events over the assessment period increase from 177 to 196 i.e. an overall increase of 19 events.

The proposal is also shown to provide a positive achievement to the delivery of fully successful SFIs in the Lower Murrumbidgee Floodplain Wetlands and Murrumbidgee River (Table 8). For example, the proposal increases the overall number of successful SFIs from 419 to 428 in the Lower Murrumbidgee Floodplain Wetlands and from 238 to 242 in the Murrumbidgee River at Balranald.

It is worth noting that the increase in successful SFIs under the proposal often results in a flow regime that over-delivers these flow components – this is generally accentuated by the benchmark result already having a higher frequency of achievement than targeted. For example, the percentage of years with a successful event of 34,640 ML/d in the Murrumbidgee River at Narrandera increases from 46% under the benchmark to 48% under the proposal, although the target frequency for this event is between 35-35% of years. This relatively large degree of over-achievement of SFIs therefore indicates that this proposal has the potential to achieve significant SDL adjustment volumes, as SFI delivery is scaled back to the target range.

Table 8. Frequency of years –that SFI events in the mid and lower Murrumbidgee region are achieved under benchmark and proposed conditions<sup>1</sup>

Indicator Description	Target freq.	% YEARS WITH FULLY SUCCESSFUL EVENTS			% YEARS WITH PARTIALLY SUCCESSFUL EVENTS			% YEARS WITH FULLY & PARTIALLY SUCCESSFUL EVENTS		
		Benchmark	Proposal (unadjusted flow rate)	Proposal (adjusted flow rate)	Benchmark	Proposal (unadjusted flow rate)	Proposal (adjusted flow rate)	Benchmark	Proposal (unadjusted flow rate)	Proposal (adjusted flow rate)
<b>Mid Murrumbidgee Floodplain Wetlands</b>										
26,850 ML/d for 45 days	20-25%	11%	11%	14%	8%	7%	10%	19%	18%	24%
26,850 ML/d for 5 days	50-60%	61%	60%	64%	5%	4%	5%	66%	64%	69%
34,650 ML/d for 5 days	35-40%	46%	45%	48%	5%	6%	6%	51%	51%	54%
44,000 ML/d for 5 days	30-35%	27%	27%	35%	12%	12%	9%	39%	39%	44%
62,250 ML/d for 3 days	11-15%	11%	11%	11%	2%	2%	2%	12%	12%	12%
<b>Total number of events</b>		<b>177</b>	<b>175</b>	<b>196</b>	<b>37</b>	<b>36</b>	<b>36</b>	<b>214</b>	<b>211</b>	<b>232</b>
<b>Lower Murrumbidgee Floodplain Wetlands</b>										
Total 175 GL	70-75%	95%	95%		0%	0%		95%	95%	
Total 270 GL	60-70%	88%	87%		5%	6%		93%	93%	
Total 400 GL	55-60%	82%	82%		9%	8%		90%	90%	
Total 800 GL	40-50%	60%	61%		7%	6%		67%	67%	
Total 1,700 GL	20-25%	26%	31%		9%	7%		35%	38%	
Total 2,700 GL	10-15%	18%	20%		4%	4%		22%	25%	
<b>Total number of events</b>		<b>419</b>	<b>428</b>		<b>39</b>	<b>36</b>		<b>458</b>	<b>464</b>	
<b>Murrumbidgee River at Balranald</b>										
1,100 ML/d for 25 days	58-77%	66%	68%		7%	6%		73%	75%	
4,500 ML/d for 20 days	54-72%	73%	73%		8%	9%		81%	82%	
3,100 ML/d for 30 days	55-73%	70%	71%		4%	4%		74%	75%	
<b>Total number of events</b>		<b>238</b>	<b>242</b>		<b>21</b>	<b>22</b>		<b>259</b>	<b>264</b>	

#### 4.2.2 Inundation of environmental assets

In addition to the above assessment of the impact of the proposal on the hydrology of the Mid Murrumbidgee River, hydraulic analysis has also been undertaken using the MIKE 11 modelling

<sup>1</sup> The colour shading on figures indicates whether the percentage of years with events has increased (green), decreased (beige) or remained the same (grey) under the proposal relative to the benchmark.

suite, to assess the change in inundation extent across the Mid Murrumbidgee Floodplain Wetlands.

This MIKE 11 analysis examined the extent of inundation across 39 individual wetlands between Yanco Weir and Hay, for flows in the Murrumbidgee River at Narrandera of 26,850 ML/d, 34,650 ML/d, 44,000 ML/d and 63,250 ML/d (i.e. the SFI flow rates). This analysis was undertaken for the benchmark and proposed conditions. The compiled results, showing the relationship between the total area of inundation / total area of wetland inundation against flow in the Murrumbidgee River are provided in Figure 30.

Figure 30 demonstrates that the proposal provides a noticeable increase in the total area of inundation for all SFIs – across the four SFI flow rates the proposal provides an average increase in total inundated area of 14% relative to the benchmark.

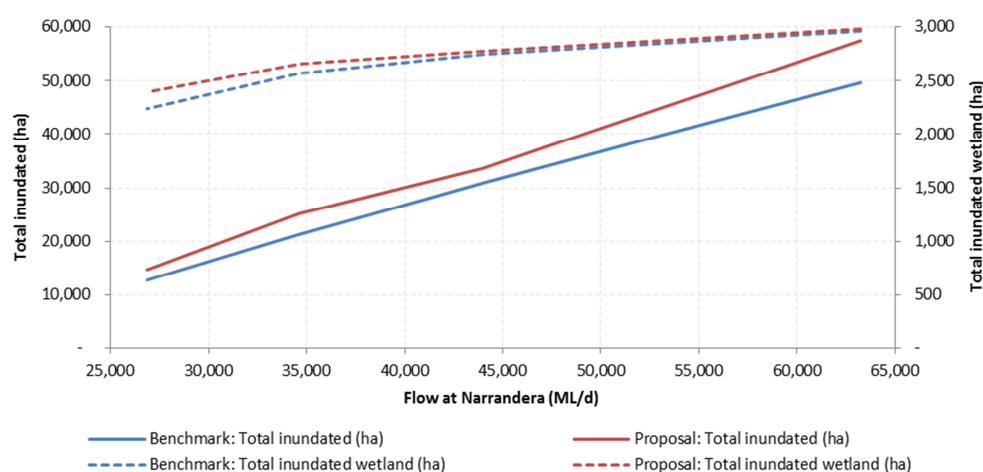

Figure 30. Relationship between area inundated and flow in Murrumbidgee under benchmark and proposal

Another outcome from Figure 30 is that the change in the area of wetland inundation (i.e. rather than total inundation) is most pronounced for the lower SFI flow rates. While the proposal provides an average increase in total wetland inundation of 3% relative to the benchmark, the percentage increase at 26,850 ML/d is almost double that at 7%.

This work confirms that the proposal not only increases the frequency of watering of the Mid Murrumbidgee Floodplain Wetlands, but also provides an increased and improved extent of inundation when watering does occur.

### 4.3 Fish passage

The current Yanco weir structure is a barrier to fish with a non-functional submerged fishway, inability for fish to pass through the structure with flows less than approximately 25,000ML/d and the presence of undershot gates impacting on fish larvae. The proposed new infrastructure will improve fish passage overall around the structures.

The Murrumbidgee River and Yanco Creek support a valuable native fish community. The recommended design philosophy for fish passage at Yanco Weir (Murrumbidgee River) and at the proposed new Yanco Creek Weir is to provide fish passage at low and medium flow events up to the drown-out level of the weir.

In summary the major expected trends in fish movements are:

**CATEGORY 1: Large-bodied native fish** (Murray cod, Trout Cod and potentially freshwater catfish):

- Adult fish will move upstream and downstream in the Murrumbidgee River, mainly from mid-winter to the end of spring and early summer.
- Some adult fish will move between Yanco Creek and Murrumbidgee River with fish entering in spring and leaving when water levels fall at the end of the irrigation season. However, there is likely to be constant exchange of fish during spring and summer.
  - Fish will be strongly cued to move by rising or falling water levels (e.g. 150-200 mm/day).
  - More adult fish will move at medium and high flows, including floods
- Larvae will be swept under Yanco Weir during spring/summer, where mortality rates will be high (Baumgartner et al. 2006). Larvae will drift into Yanco Creek where there will likely be a low level of recruitment.
- Juveniles and sub-adults will likely move upstream and downstream at Yanco Weir in spring and summer, some fish will also move in and out of Yanco Creek. Juvenile fish will move at low, medium and high flows.

**CATEGORY 2: Medium-bodied native fish** (mainly golden perch and silver perch and possibly bony herring)

- Adult fish will migrate upstream and downstream in spring and summer and especially during a river rise and flooding (Mallen-Cooper 1999).
- Eggs and larvae will drift downstream in spring and summer where there is high mortality associated with under-shot weir gate passage. Larvae will drift into Yanco Creek where there will be little or no recruitment.
- Juveniles migrate upstream, especially from mid/late-spring and summer though few appear to actively enter Yanco Creek.

**CATEGORY 3: Small-bodied native fish** (mainly carp gudgeons, Australian smelt and Murray-Darling rainbowfish and unspoked hardyhead)

- Adult fish will migrate in the Murrumbidgee River throughout spring and summer and to-and-from Yanco Creek (see Stuart et al. 2008 for an example in the lower Murray River; Lyon et al. 2010).
- Larvae will drift under the Yanco Weir gates and into Yanco Creek.
- Juveniles will likely inhabit and complete their life-histories in Yanco Creek.

**CATEGORY 4: Non-native fish**

- Adult fish, particularly carp, will migrate in the Murrumbidgee River from spring to autumn and use fishways (Jones and Stuart 2008). Some fish will also enter Yanco Creek.
- Larvae, particularly of carp, will enter Yanco Creek in spring and summer. Some larvae will be spawned in Yanco Creek.
- Juveniles will reside in Yanco Creek and grow to adults.

The objectives from this approach are therefore to:



- Provide safe downstream passage of eggs, larvae, juvenile and adult fish.
- Provide upstream passage of medium and large-bodied fish (60-1000 mm long; Category 1 & 2) over a wide range of flows, including high flows.
- Improve habitat connectivity for Category 1 & 2 fish that migrate at macro (100s km) and meso (10s km) scales

The fishway design is based on fish biology and hydraulically caters for a variety of fish behaviours and especially medium/large fish (Category 1 & 2) which require continuous attraction flow and traditionally pass more efficiently through pool-type fishways than locks.

## 5 Potential adverse impacts

### 5.1 Risk assessment framework

This section considers project development and construction risks that could impact on project delivery. Priority risks are highlighted through a risk assessment process that rates the level of initial risk and residual risk after mitigation.

This risk assessment was completed in line AS/NZS ISO 31000:2009. This is a widely adopted and robust framework for these types of projects) and has been applied to be consistent with earlier SDL offset business cases. Table 9 and Table 10 provide an overview of the risk matrix and definition of the levels of risk.

Table 9. ISO Risk Matrix

	Consequence			
Likelihood	Minor	Moderate	Severe	Catastrophic
Remote	Very Low	Very Low	Low	Low
Unlikely	Very Low	Low	Moderate	Moderate
Possible	Low	Moderate	High	High
Likely	Low	Moderate	High	Very High
Almost certain	Moderate	High	Very High	Very High

Table 10. Definitions of the levels of risk

Very Low	There is no reasonable prospect the project objectives will be affected by the event
Low	The event is a low priority for management but risk management measures should be considered
Moderate	The risk is a moderate priority for management. Risk management measures should be undertaken.
High	The risk is a high priority for management. There is a reasonable likelihood it will occur and will have harmful consequences. Risk management is essential.
Very High	The risk is a very high priority for management. It is likely to occur and will have very harmful consequences. Risk management is essential.

## 5.2 Risk categories overview

The primary risks associated with this project can be grouped into economic, environmental impact, governance and project management, modelling and heritage impacts. Table 11 presents an overview of the key risk areas.

Table 11. Overview of risk areas

Economic	Water is used for irrigation, stock and domestic purposes which drives agricultural production. Impacts on water supply may have an impact on agricultural production and in turn economic impacts to landholders.
Environmental impact	Environmental impacts can be broadly grouped into impacts on the values (assets and functions) from changes in hydrology, introduction of barriers to fish, and impacts on the values through construction and operation activities.
Governance and project management	Governance and project management risk relates to decision making, construction and operations management and managing costs.
Modelling	The ecological benefits and SDL Adjustment documented in this Business Case are a product of the modelling.
Heritage impacts	Heritage impacts are largely relate to any heritage classified assets and any physical impacts through construction and ongoing management activities.

The risk management framework is applied to these risk categories in [Table 12](#) and further and more detailed discussion is provided in subsequent sections.

Table 12. Overview of risk assessment and mitigation for project development and construction risks

Description of threat	Likelihood	Consequence	Initial risk	Mitigation	Residual risk	Resolution
<b>Economic</b>						
Irrigation landholders do not receive their water right through construction of a regulator on the Yanco creek.	Unlikely	Moderate	Low	The management of the structure will be governed by operational rules.	Low	Construction of the asset must not proceed until operational rules are agreed on by water diverters and the structure management entity.
Operational rules are created which limits flows travelling down the Yanco impacting on irrigators, and stock and domestic needs.	Unlikely	Moderate	Low	The operation rules need to be developed to ensure there is no detrimental impact to meeting agreed landholder water provision needs (volume and timing).	Low	Irrigation landholders must be involved in the initial agreement of operational rules for the regulator and must be involved should the management authority wish to modify those operational requirements.
Impact on town water supply to Jerilderie, Conargo Shire towns.	Unlikely	Severe	Moderate	The operation rules need to be developed to ensure there is no detrimental impact in the provision of water for potable use.	Low	The process for developing operational rules must give consideration to meeting town water supply requirements.

Description of threat	Likelihood	Consequence	Initial risk	Mitigation	Residual risk	Resolution
<b>Environmental impacts</b>						
Construction of the new Yanco Creek Regulator will reduce waterway connectivity between Yanco Creek and the Murrumbidgee River impacting of large bodies fish movement.	Likely	Severe	High	<p>Large bodied fish need to migrate to complete their lifecycle.</p> <p>Construction of a fishway will provide fish passage for larger bodied fish (including juvenile fish) when the regulator is closed.</p> <p>Regulator will however not be closed all the time and during periods when it is open there will be no barrier to large bodied fish movement.</p>	Low	<p>Fish ladder detail design to ensure ongoing input from a qualified fish specialist to maximise its design efficiency.</p> <p>Operational rules need to consider key times of fish movement between the Yanco Creek and Murrumbidgee River</p> <p>OEH must be involved in the initial agreement of operational rules for the regulator and must be involved should the management authority wish to modify those operational requirements.</p>
Construction of the new Yanco Creek Regulator will reduce waterway connectivity between Yanco Creek and the Murrumbidgee River impacting of small bodied fish movement.	Likely	Moderate	Moderate	<p>Small bodied fish generally do need to migrate to complete their lifecycle (although the science on this for all species is not complete) and the issue receives a consequence score of moderate.</p> <p>The current proposal for a vertical slot fish way does not suit small bodied fish and even if the regulator is open, small bodied fish will have difficulty passing through the higher velocity created by the gates.</p>	Moderate	Construct fish passage to service the migratory needs of large bodied fish

Description of threat	Likelihood	Consequence	Initial risk	Mitigation	Residual risk	Resolution
Flow regulation down the Yanco (reduction inflows) would result in the reduction in the suitability of the waterways as habitat for State and Federally listed species; including Trout Cod, Murray Cod, Murray Crayfish, Silver Perch, Pygmy perch, Purple-spotted gudgeon and the listed Murray-Darling Basin population of Eel-tailed / Freshwater Catfish.	Likely	Severe	High	The operation rules need to be developed to ensure there is no detrimental impact to flow requirements to support native fish populations	Low	OEH must be involved in the initial agreement of operational rules for the regulator and must be involved should the management authority wish to modify those operational requirements.
Raising the weir on the Murrumbidgee river will result in further detrimental impacts on medium bodied fish passage	Likely	Severe	High	The current structure is not conducive to fish passage. It has a non-functional submerged passage and flows of < 2500ML/d fish results in no fish passage with the current weir structure and its hydrology.  A more suitable fish passage option has been designed as part of this business case to mitigate the existing issues and mitigate any impacts of raising the weir structure for medium bodied fish	Low	Suitable fishways are constructed at the new Yanco Creek Regulator and Yanco Weir to facilitate upstream migration of native fish, particularly during elevated environmental flows for the mid-Murrumbidgee riparian zones which will trigger mass migrations of medium and large-bodied fish.
Raising the weir on the Murrumbidgee river will result in further detrimental impacts on small bodied fish passage	Unlikely	Minor	Low	Small fish already do not have the ability to pass through the structure and the construction of a new asset will not change this status quo	Low	

Description of threat	Likelihood	Consequence	Initial risk	Mitigation	Residual risk	Resolution
Threatened flora and fauna are impacted on during asset construction and operational activities with particular reference to flora and fauna species identified in Section 9.1.3 of this report.	Possible	Moderate	Moderate	The initial EIA was a desktop review and identified species in the vicinity. These areas are degraded by past works and the likelihood of threatened species being present is low.		A complete flora and fauna assessment needs to be undertaken as part of the detailed design of the new infrastructure.
Increased ponding of water by the new structure on the Murrumbidgee would change the diverse hydrodynamic environment to slow moving pool impacting on the habitat of native fish.	Likely	Moderate	Moderate	The height at which water is held and its duration at different heights is important in the mitigation of this risk. Water ponding is not a permanent outcome and the timing of the ponding will be governed by the development of operational rules.	Low	Operational rules need to be developed to ensure the hydrology of the river upstream of the weir do not have a substantial impact on native fish
Flora and fauna (other than fish already mentioned) upstream of the weir may be impacted on by an increased flooding (duration and depth) as a result of the increased pooling of water behind the weir.	Likely	Moderate	Moderate	The height at which water is held and its duration at different heights is important in the mitigation of this risk. Water ponding is not a permanent outcome and the timing of the ponding will be governed by the development of operational rules.	Low	Operational rules need to be developed to ensure the hydrology of the river upstream of the weir do not have a substantial impact on any important flora and fauna species

Description of threat	Likelihood	Consequence	Initial risk	Mitigation	Residual risk	Resolution
Increased backwatering may create localised salinity impacts.	Unlikely	Minor	Low	<p>The height at which water is held and its duration at different heights is important in the mitigation of this risk.</p> <p>Water ponding is not a permanent outcome and the timing of the ponding will be governed by the development of operational rules.</p>	Low	
<b>Governance and project management</b>						
Lack of ability to reach a consensus on operational rules	Possible	Severe	High	<p>The process of setting operational rules may result in different opinions by parties representing fish passage, irrigation requirements and broader ecological objectives of the works.</p> <p>There needs to be a process to ensure a decision can be made</p>	Low	<p>The development of the operating rules should be guided by a terms of reference and that terms of reference should nominate a key authority and individual to make the final determination of the operational rules</p> <p>A NSW Government representative needs to be provided with authority to make a final recommendation for NSW based on balance of any differing views.</p>



Description of threat	Likelihood	Consequence	Initial risk	Mitigation	Residual risk	Resolution
Costs exceed approved funds due to errors or emissions or because of costly mitigation requirements	Possible	Severe	High	50% contingencies factored into cost estimates for the construction works required. Provision for additional Project Management Cost including modelling is factored into estimates.	Low	
Unforeseen delays in project delivery due to flooding	Possible	Severe	High	Contingencies for flooding are factored in.	Low	
Unforeseen delays in project delivery due to adverse weather, approval processes or conflict with stakeholders	Likely	Moderate	Moderate	Contingencies for adverse weather are factored in. Communication plans and approvals processes will be put in place.	Low	
<b>Heritage</b>						
Heritage values are impacted on through construction or operation of the new assets.	Unlikely	Severe	Moderate	The initial EIA was a desktop review and identified little heritage values in the study area. These areas are degraded by past works and the likelihood of heritage values being present is low.		A complete heritage assessment needs to be undertaken as part of the detailed design of the new infrastructure.

### 5.3 Impact on diversions

The Yanco Creek system is an important irrigation asset. The system provides water to stock and domestic users and irrigation businesses along its length. In all, the creek system supports over 200 licensed water users and supplies water to 195,000 ML of licensed entitlement.

According to WaterNSW figures in 2007, the following water entitlements were held on the Yanco Creek system:

Category of Entitlement	Number of Licenses	Number of Entitlements
Local Water Utility	4	8,336
Domestic and Stock	152	5,008
High Security	10	1,054
General Security	173	152,521
Supplementary	77	27,853
Total	416	194,772

(Report: Jim Parrett, State Water, March 2007, Unpublished)

It is likely that the number of general security water entitlements is likely to have reduced by some 20,000 to 30,000 entitlements as a result of recent environmental water buy backs since 2007.

The community consultation identified that landholders were concerned that the construction of the Yanco Creek regulator would impact on their ability to receive their water entitlement for irrigation and stock and domestic. This issue would be considered the largest potential third party impact.

To examine this issue, IQQM modelling of the proposal assessed the diversions in the Murrumbidgee system under the benchmark and the proposal (Table 13). Results to date show that the proposal results in an increase in total diversions for Yanco regulator compared to the benchmark.

This issue may be completely mitigated by the development of operational rules to ensure there is no detrimental impact to meeting agreed landholder water provision needs (volume and timing). Given the degree of community concern, it is proposed that irrigation landholders are involved in the initial agreement of operational rules for the regulator and subsequently involved should the future management authority wish to modify the agreed operational requirements.

The impact on town water supply has been raised however the operational rules will ensure this issue is totally mitigated.

Table 13. Diversions in the Murrumbidgee system under the benchmark and proposal (GL/year)

	Benchmark	Proposal	Difference
<b>Whole valley</b>			
Gross diversions	1630	1635	+5 (0.3%)
<b>On allocation divs (gross)</b>			
On allocation divs (gross)	1310	1314	+4 (0.3%)
Off allocation divs (gross)	73	73	0 (0%)
<b>Lower bidgee</b>			
Tier1	11	12	+1 (9.1%)
Tier 2 and 3	135	133	-2 (-1.5%)
Flood	49	56	+7 (14.3%)
<i>Total less return flow</i>	166	170	+4 (2.4%)
Redbank diversions	58	55	-3 (-5.2%)
<b>Yanco/Colombo</b>			
Irrigation On allocation	269.1	270.7	+1.6 (0.6%)
Irrigation Off allocation	5.3	5.2	-0.1 (-1.9%)
<b>Total</b>	<b>274.4</b>	<b>275.9</b>	<b>+1.5 (0.5%)</b>

## 5.4 Altering hydrology in the Yanco creek

The installation of a regulator is proposed to allow for the alteration of hydrology in the Murrumbidgee River and Yanco Creek itself. Hydrologic modelling of the proposal in IQQM estimates that the proposal will have the overall long-term effect of increasing annual average flow in the Murrumbidgee River towards Balranald, while reducing annual average flow in the Yanco Creek (Table 14).

Table 14. End of system flows under the benchmark and proposal (GL/year)

	Benchmark	Proposal	Difference
Balranald	1717	1778	61 (3.6%)
Darlot	302	243	-59 (-19.5%)
Forest	57	52	-5 (-8.8%)

Total	2075	2073	-2 (-0.1%)
-------	------	------	------------

There is a significant body of work undertaken on the Yanco Creek in regards to its environmental flow needs and recommendations have been provided in the Yanco Creek Environmental Flows study (Alluvium 2013)

#### 5.4.1 Impact of the proposal on environmental flow performance in Yanco Creek

##### Approach to assessing environmental flow performance

The influence of the proposal on the achievement of the environmental flow recommendations in the Yanco Creek system was assessed against 99 years (1910-2009) of modelled flows provided by NSW DPI Water. This 99 year period – which excluded the first 15 years of modelled flows from 1895 to 1910 - was chosen to provide a consistent reporting framework to that used when developing the environmental flow requirements for the Yanco Creek system (Alluvium 2013).

The following environmental flow performance assessment examines the influence of the proposal, relative to the benchmark, through consideration of three metrics:

- **Baseflow** performance: assessed as a percentage of years that the environmental flow recommendation is achieved (i.e. the recommended flow is equalled or exceeded on every day in the year).
- Number of fresh, bankfull and overbank events: expressed as the percentage of years in the flow record that the recommended number of events is achieved
- Duration of fresh, bankfull and overbank events: expressed as the percentage of target events achieved that persist for the recommended duration.

These metrics are examined for each reach in the Yanco Creek system.

##### Summary of results

A detailed assessment of the influence of the proposal on environmental flow performance in Yanco Creek is provided in Appendix 2. Appendix 2 provides temporal plots and summary statistic on the achievement of each flow recommendation under the benchmark and proposed conditions.

Those detailed findings for each flow recommendation in each reach are summarised at a high level in Table 15 which identifies how the proposal affects the achievement of flow recommendations relative to the benchmark. The following broad descriptions are used to identify this change:

- Negligible change i.e. the frequency and duration of events under the proposal is equal to, or similar to, the frequency and duration of events under the benchmark
- Improved duration i.e. the proposal provides an increase in the percentage of target events achieved that persist for the recommended duration
- Improved (or reduced) frequency i.e. the proposal provides an increase (or decrease) in percentage of years in the flow record that the recommended number of events is achieved

Table 15 identifies that at a broad level, while there are some fluctuations across the reaches in the influence on specific flow events (e.g. some events improve in frequency/duration while others reduce in frequency/duration), the proposal leads to little discernible net change from the benchmark. As such, the proposal tends to maintain the benchmark achievement of environmental flow events throughout the Yanco Creek system. Of the events adversely affected, bankfull events are most notably affected in multiple reaches of the Yanco Creek.

Table 15. High level summary of the influence of the proposal on environmental flow performance in Yanco Creek

Reach	Baseflows	Summer fresh	Winter fresh	Bankfull	Overbank
1	Negligible change	Negligible change	Negligible change	Negligible change	Negligible change
2	Negligible change	Negligible change	Improved frequency but reduced duration	Reduced frequency and duration	Negligible change
3	Negligible change	n/a	n/a	n/a	Reduced frequency
4a	Negligible change	Improved frequency and duration	Negligible change	Reduced frequency but improved duration	Negligible change
5	Negligible change	Negligible change	Reduced frequency	Reduced frequency	Negligible change
6	Negligible change	Negligible change	Negligible change	n/a	Negligible change

## 5.5 Creation of backwater

The creation of the backwater from the weir is a direct product of raising the weir and increasing storage. The risks of this activity falls into three main categories of impact on salinity, reducing the hydro-dynamically diverse flowing waterway (with emphasis of impact on the lower parts of the inflow tributaries), and localised impacts on flora and fauna through increased water ponding and a change in the water regime.

The impact on these three categories of risk is largely controlled by the period at which the weir will be operated to produce higher backwater elevations than occurred under benchmark conditions. Figure 31 quantifies this to some degree, by showing the percentage of time the weir is expected to be held above a given water level under the proposal, based upon long-term hydrological modelling of the proposal in IQQM, and proposed weir operation (as described in Section 3.2.3).

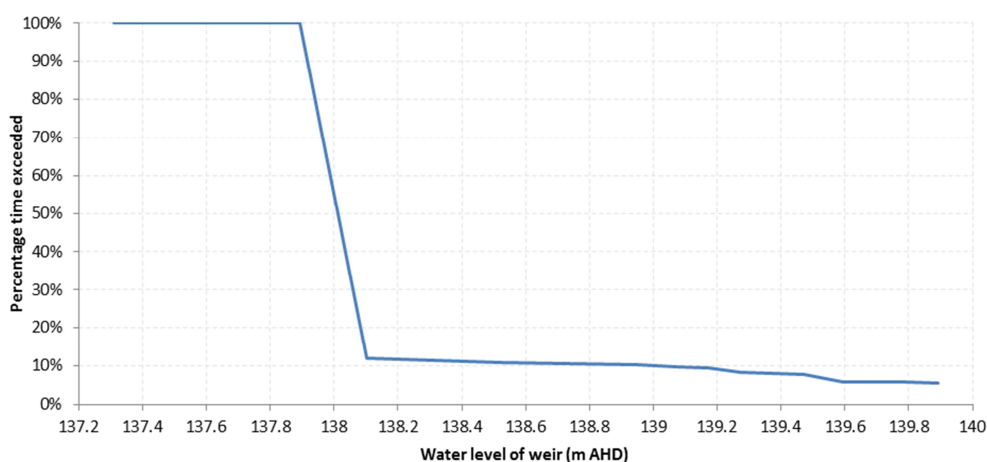

Figure 31. Level duration curve, showing percentage of time the weir is expected to be held above a given water level

The concern about impact on salinity was raised by Victoria, South Australia and the Commonwealth. Large waterway systems are normally the discharge point not only for the regional watertable aquifers (that are often saline) and also the underlying confined aquifers by way of upward leakage. In a general sense these aquifers drain to the waterway where the waterway would be classified as a discharge area.

Increasing the pondage of water through raising the weir level may mean the storage has a sufficient head of pressure to act as a recharge zone and create a gradient of water moving away from the river, which may result in rising of the saline watertable in adjacent areas and creating a localised salinity problem.

A hydrogeological assessment has not been undertaken, however it is proposed that this risk is quite low as the Business Case does not propose to significantly increase the pondage permanently. An operational regime will be developed to optimise the system to achieve the right balance between servicing the irrigation requirements and improving flows to the mid Murrumbidgee wetlands.

Raising of Yanco Weirs by 2.5 m will create a larger weir pool (refer to Figure 24 in Section 3.2.3), inundating significant habitat for flow-dependent State and Federally listed species (e.g. Trout and Murray Cod), thus potentially changing hydro-dynamically diverse flowing waterways into static bodies of water that may favour exotic pest species such as carp.

The desktop flora and fauna review described native vegetation and Inland Grey Box Woodland in the Riverina, NSW South Western Slopes, Cobar Penneplain, Nandewar and Brigalow Belt South Bioregions (Inland Grey Box Woodland) (EPBC Act and TSC Act) that occur upstream of the study area on banks of the Murrumbidgee River and its tributaries may be impacted as a result of the increased inundation, through over watering. In turn, fauna species that rely on these communities as habitat may also be impacted.

Again, a key issue is that the ponding is not a permanent outcome and the timing of the ponding will be governed by the development of operational rules. Any impacts on fish need

to consider the actually agreed operating rules and the broader net benefits of allowing fish passage for medium bodied fish in flows less than 2500 ML/d (current functional barrier).

The impact on changes to the hydrology as a result of the operating protocol adopted and impact on fish (and other fauna) along with impacts of greater inundation of riparian flora has not been quantified and does require further assessment in the detailed design. The level of impact is primarily a result of the operating protocol that is implemented.

## 5.6 Blocking fish passage between the Murrumbidgee and Yanco creek

Installation of a regulator between the Murrumbidgee and Yanco Creek will impact on fish movement. The design solution provided in this Business Case provides passage for large bodied fish (including juveniles which are >80 mm long) because these fish have declined regionally. This approach was undertaken given large bodied fish need to complete obligatory migrations to complete their lifecycle and these migrations can be over a large spatial scale (e.g. 10s-100s of km) and these fish target flowing water for spawning.

In addition the operation of the regulator means the gates will not always be closed and large bodied fish will be able to migrate through the structure when it is open.

Small bodied fish can complete their life cycle at a small spatial scale (hundreds of metres) and they are habitat generalists. Small bodied fish (<60 mm long) are often less successful using a long vertical slot fishway and are better suited to the use of a fish lock (which is not so suitable for large bodied fish).

Small bodied fish may not be able to pass through the regulator when it is open due to increased water velocities passing through the gates. It would be expected that there would be increased mortality of small bodied fish as they attempt to disperse upstream and are blocked by the structure and are then subject to predation by piscivorous birds and large fish.

Generally small bodied fish do not need to migrate to complete their life cycle and the installation of the regulator is a low risk of impacting on populations in the Yanco Creek. Small bodied fish are also highly abundant. However, the science in regards to small bodied fish is incomplete and there may be some impacts on some species which do require upstream passage for life cycle reasons and there may be some intergeneration impacts.

The consideration to fish issues needs to be an on balance decision. The construction of the Yanco Creek structure will likely impact on small bodied fish, but the structure on the Murrumbidgee will remove a major fish barrier to migratory species.

## 5.7 Resolving operational rules

The business case presented is very much underpinned by the development of operational rules for both regulation structures. These are not static structures, but managed to allow flexibility in the delivery of water to meet multiple objectives.

Multiple objectives invariably means there are multiple interest groups who need to be involved in the development of these rules. Table 16 provides an overview of the groups and the key issues raised during the consultation period.

Table 16. Likely interest groups to be involved in the development of operational rules

Entity	Key drivers based on consultation
Fisheries	Best outcome for fish passage and impact of current small bodied fish populations.
OEH	Best outcome for environmental assets and values
Irrigation landholders Yanco Landholders	Best outcome for provision of irrigation water Best outcome for provision of environmental water into Yanco Creek System
Retail Water Authorities	Best outcome for the provision of potable water to the community
MDBA	Best outcome for the watering of the Mid Murrumbidgee wetlands and other downstream assets.
WaterNSW	Best outcome for cost effective operation and flexibility of operations.
NOW	Best outcome for sharing the water

Solving problems involving multiple objectives often require an ‘on balance’ decision and some compromised considerations. The development of the operational rules are a key part of the management of the structures to meet the needs of these parties and the process needs to be undertaken in a highly consultative way.

In order to ensure an outcome it is proposed that the process is led by the NSW government with the authority to make a final decision on the operational arrangements on behalf of all NSW government bodies.

## 5.8 Risk assessment conclusion

Overall the largest residual risks associated with this project are associated with the resolution of the operating rules and fish passage for small bodied fish.

The resolution of operating rules of both the weir structures on the Murrumbidgee River and Yanco Creek is a significant piece of work and constitutes a significant risk to the project until they are resolved. The rules need to consider;

- Backwatering impacts on fish and broader ecology values (flora and fauna) in the Murrumbidgee
- Provision of flows to meet landholder and ecological flow requirements in the Yanco Creek system.
- Provision of flows to meet community potable water needs
- Most effective watering of the Mid Murrumbidgee wetlands and other downstream assets.
- Cost effective operation and flexibility of operations.



In order to ensure an outcome it is proposed that the process is led by the NSW government with the authority to make a final decision on the operational arrangements on behalf of all NSW government bodies.

The only risk that is planned to be mitigated is the impact on movement of small bodied fish upstream of weir structures as it is not possible to provide a satisfactory fish passage suitable for all types of fish.

On the Murrumbidgee River there is currently no effective fish passage through a number of key flow regulation structures for small bodied fish and the proposed changes do not alter that status-quo. There is no net negative impact on small bodied fish in the Murrumbidgee River from this proposal.

As per section 5.6, although it is a low risk, there is a negative effect on the common and abundant small bodied fish in the Yanco Creek as the new regulator will limit their ability to move upstream to the Murrumbidgee River. Despite migration not being required as an obligatory part of their lifecycle, summer flows will trigger small bodied fish to travel upstream and there would likely be greater mortality rates at the weir barrier. The presence of Yanco Creek regulator also has the potential to reduce passage for large fish as no fishway is 100% effective.

## 6 Technical feasibility and fitness for purpose

### 6.1 Options assessment

A range of alternative options have been considered and excluded from the design. They are summarised below:

#### **No increase in weir pool level**

Whilst this approach was significantly cheaper there were impacts on the ability to meet environmental flow targets in the Yanco Creek system.

The cost for installing a regulator and fishway at Yanco Creek, upgrading the existing Yanco regulator for overshot discharge, and provision of a fishway on the Murrumbidgee River was estimated at [REDACTED].

We also looked at a 'minimum cost' option that did not include any works on the Murrumbidgee River, but just installed a new regulator and fishway on Yanco Creek. This cost was [REDACTED].

Because of the requirement to demonstrate no net impact on affected systems this approach has not been taken up.

#### **Upgrading existing gated Yanco regulator and raising existing (older) fixed crest Yanco Weir**

Raising the existing Yanco weir to accommodate increased weir pool level has a large impact on the capacity to deliver flows through the existing regulator. Thus the existing regulator needs to be supplemented by additional gates to achieve a greater discharge capacity.

The additional gates can be provided adjacent to the existing regulator gates, or built into the current Yanco fixed weir site. The former proposal is limited by the available space and dimensions of the waterway at the existing regulator site, while the second option creates an issue for fish passage if discharge is from two competing branches of the waterway.

The existing Yanco Regulator would need to be upgraded with larger gates to accommodate the increased weir pool. However the existing hoist system and the gate track wheel system, do not have the capacity for larger, heavier gates.

There is a heavy emphasis on providing for downstream fish passage at this site. This means that the type of gate needs to be changed, or a second gate operated with it as a 'split-leaf' type gate. The nature of the seals and wheel mountings, as well as the slots in the support piers mean that it would be difficult to marry a second leaf and achieve a satisfactory seal.

The gates could be extended, but the hoist bridge would need to be raised to allow the gates to be lifted clear of the flood level. Alternatively the gate sill can be raised to cover part, or all, of the weir pool increase in level. However this further decreases the capacity of the regulators and adds to the supplementary capacity that will be required.

Further the analysis of the existing structure indicates that any weir pool increase of more than 1m will affect the structural stability of the structure. This means that substantial upgrade works will be required to restore stability under the higher hydraulic loads.

We looked at the costs associated with raising the weir pool by 1m or 2m rather than the 2.5m that has been adopted (Figure 32).

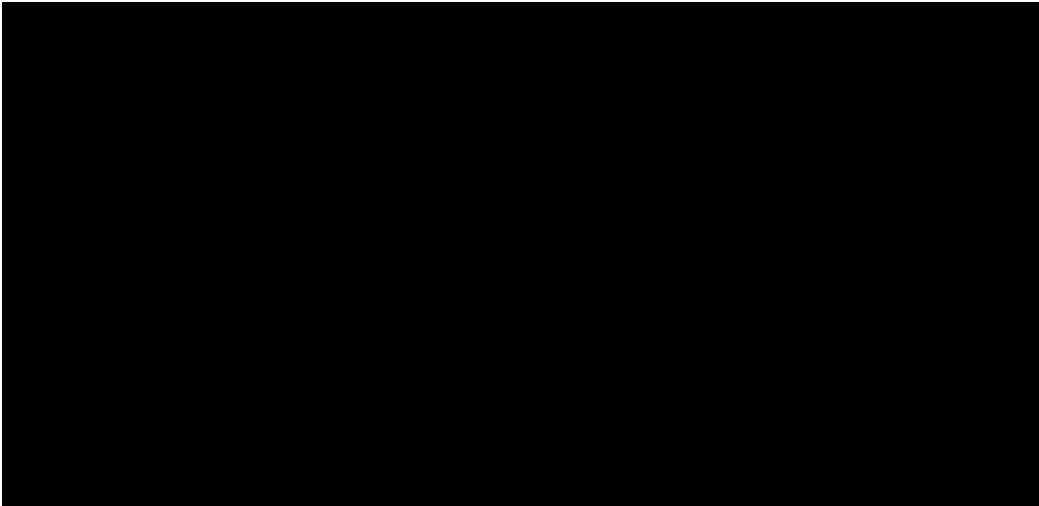

## 6.2 Ecological considerations associated with works site

A desktop EIA was undertaken to identify any impacts on this proposal. The complete report is provided in Appendix 3.

### 6.2.1 Threatened flora and RoTAP

The desktop research identified four threatened flora and/or RoTAP species as occurring within 10 km of the study area (the search area). Only one species (*Diuris tricolor*) was found to have a medium or high likelihood of occurrence in study area. A number of species are not listed on the EPBC Act or TSC Act but were identified as rare RoTAP species that occur in the broader search area. This includes; Small-flower Goodenia *Goodenia pusilliflora*, Green Honey Myrtle *Melaleuca diosmifolia* and *Caladenia rileyi*.

### 6.2.2 Threatened fauna

The desktop research identified a range of threatened fauna (including aquatic threatened fauna) as occurring within 10 km of the study area (the search area).

| Table 17

**Table 17** presents threatened fauna with a medium to high likelihood of occurrence in the study area and search area.

Table 17. Threatened fauna in the site area

Common name	Study area (recorded) – yes/no	Search area (recorded) – yes/no	EPBC Act	TSC Act /FM Act
Birds				
Bush Stone-curlew	No	Yes		E1
Pied Honeyeater	No	Yes		V
Speckled Warbler	No	Yes		V
Brown Treecreeper (eastern subspecies)	Yes	Yes		V
Varied Sittella	Yes	Yes		V
Black Falcon	No	Yes		V
Painted Honeyeater	Yes	Yes		V
Little Eagle	No	Yes		V
Turquoise Parrot	No	Yes		V
Barking Owl	No	Yes		V
Scarlet Robin	No	Yes		V
Superb Parrot	No	Yes	VU	V
Grey-crowned Babbler (eastern subspecies)	No	Yes		V
Australian Painted Snipe	No	Yes	EN	E1
Diamond Firetail	No	Yes		V
Mammals				
Southern Myotis	No	Yes		V
Koala	No	Yes	VU	V

### 6.2.3 Threatened ecological communities

The Threatened Ecological Communities for the study area were ascertained through desktop research across a range of detailed mapping exercises undertaken and collectively captured by the OEH Six Viewer Portal (2013) or DPI such as the Central Southern – VIS 3884 (Maguire et al. 2012) and current NSW Fisheries DPI list of endangered and vulnerable ecological communities.

This map datum was then assessed against the desktop research through the OEH BioNet Atlas and DoE PMST to determine which of the ecological communities within the region comprise TEC under TSC Act or EPBC Act.

Ecological Communities listed under the FM Act were determined from the NSW DPI listings (DPI 2007). The Threatened Ecological Communities with a medium or high likelihood of occurrence was the Lower Murray River aquatic ecological community.

## **6.3 Heritage considerations associated with works site**

### **6.3.1 Cultural heritage**

A desktop heritage assessment was undertaken at this site. The Office of Environment and Heritage (OEH) maintains a database of Aboriginal sites within NSW under Part 6 of the NSW National Parks and Wildlife Act 1974. Aboriginal objects and places in NSW are legally required to be registered on the Aboriginal Heritage Information Management System (AHIMS) register.

A search of the NSW Office of Environment and Heritage (OEH) Aboriginal Heritage Information Management System (AHIMS) was conducted on the 15 May 2015 (ID173344). The search area covered a 5 km search area centred on the study area. No Aboriginal archaeological sites listed on AHIMS are currently within the study area or the 5 km radius.

The study area covers the river flats to a distance of approximately 250 m from the Murrumbidgee River. To the south of the River the study area also contains Yanco Creek and associated creek flats. Both of these landforms are considered to be sensitive landforms and require further investigation under the Due Diligence Code.

The potential for unidentified aboriginal sites to be present in these landforms is considered to be moderate to high based on the distribution of sites in the wider region of the Riverine lowlands and previous site distribution models developed by previous researchers (OzArk 2009, NOHC 2004, Edmonds 2001, Wood 1992 (a and b)). Previous assessments have also shown that specific areas of impact may occur in areas with lower potential due to previous disturbance or minor topographic features (OzArk 2009).

Wider plains and gently sloping areas are considered to hold low potential for Aboriginal sites to occur as they are a distance from resources and have been subject to previous disturbance.

Sections of the study area appear, based on aerial photography to have suffered from high levels of previous disturbance associated with the construction of irrigation weirs, access roads and associated tree and vegetation removal. Undisturbed areas of dense tree cover are present along the southern bank of the Murrumbidgee and along Yanco Creek. The disturbance may have impacted and or removed heritage sites but the potential for them to occur, albeit in a disturbed context is considered to be moderate. Within undisturbed areas the potential for sites to occur is considered also to be moderate.

No known Aboriginal objects or places have the potential to be impacted by the proposed works. Additionally the proposed works will take place within a landform considered sensitive and holding moderate potential for unrecorded sites to be present.

### **6.3.2 Historical significance**

Relevant heritage register searches were completed. These searches resulted in the identification of one heritage place (Yanco Weir) being present within the study area and two additional sites being located in the vicinity but outside the zone of impact. The Yanco weir

is listed on the NSW Heritage Register and WaterNSW's s 170 register. The project contains two historical items (Yanco Weir and McCaugheys Irrigation area) on Leeton LEP.

The creek systems and surrounds have been previously assessed for their heritage values with listing to various State, local and agency registers. The area would appear not to have been subject to a systematic or thorough survey for historical heritage items, but that known items have been registered on local LEPs. The area does contain low potential for further unidentified heritage sites associated with the early irrigation or settlement of the area but in relation to the known heritage items any further items would most probably be of low and local significance only.



## 7 Stakeholders

### 7.1 Overview

A Stakeholder Management Strategy (or communication plan) guided engagement and communication activities for the project. An overview of the key components of the strategy and the outcomes from the business case development phase is provided in the following sections.

Agencies and stakeholder representative groups materially affected by the proposal have been consulted in the development of this business case. These groups include:

- Murray-Darling Basin Authority
- WaterNSW
- NSW DPI Water
- Office of Environment and Heritage (NSW)
- NSW Parks and Wildlife
- NSW Fisheries
- Department of Environment (Commonwealth)
- Commonwealth Environmental Water Office
- YACTAC – Yanco Creeks and Tributaries Advisory Council
- Murrumbidgee Customer Service Committee
- Local Land Services
- Environmental Watering Advisory Groups

A workshop was held on 13 May 2015 (at Hume Dam, Albury) and representatives of the state and Commonwealth agencies were invited to attend. The workshop attendees identified the potential risks of this proposal and interested stakeholder groups. Minutes of the workshop are provided in Appendix 5 of this business case.

Following this workshop, targeted discussions with all other interest groups listed were undertaken. The purpose of these discussions was to identify the potential risks and concerns regarding the proposal. Issues raised during consultation (where appropriate) have been addressed in this business case (refer Section 5).

Due to the timeframe for the development of this business case, WaterNSW has not engaged with all individual landholders one-on-one, rather they have targeted interest groups that represent the broader community views (such as YACTAC, Murrumbidgee CSC, Local Land Services, and EWAG). Further engagement is proposed in the next stages of the project.

## 7.2 Stakeholder map

**Table 18** lists the interested stakeholders with an interest in this proposal. Engagement with all stakeholders listed has been initiated and a commitment provided to continue engagement beyond the submission of this business case.

Table 18. Map of agencies, groups and individual stakeholders with an interest in the SDL adjustment proposal, including their interface with proposal and areas of concern

Stakeholder	Role / responsibility	Interface with the proposal	Areas of concern	Awareness of proposal
Murray-Darling Basin Authority	Operations planning Constraints management Hydrological modelling Water policy	Influence of constraints in Murrumbidgee	Achievement of ecological outcomes Interaction with CMS	Consulted in development of business case
NSW DPI Water	Water policy/planning and water resource allocation	Water resource manager	Impacts on NSW water users and riparian communities	Proponent of business case Co-sponsor of proposal
WaterNSW	Local water delivery and operations	Water manager	Impacts to WaterNSW customers Changes to system operations	Proponent of business case Co-sponsor of proposal
Office of Environment and Heritage (NSW)	NSW Environmental policy/planning	Environmental water planning and delivery	Achievement of ecological outcomes Interface with other environmental water use	Consulted in development of business case
Department of Environment (Commonwealth)	Support management of Commonwealth environmental water portfolio	Environmental water planning	Achievement of ecological outcomes Interface with other environmental water use	Consulted in development of business case
Commonwealth Environmental Water Office	Management of Commonwealth environmental water portfolio	Environmental water planning Interaction with entitlement portfolio	Achievement of ecological outcomes Interface with other environmental water use	Consulted in development of business case
Department of Environment, Water and Natural Resources (South)	Management of water and environment (South)	Water planning Downstream water user	Implications of proposal on downstream assets and water	Aware of proposal

Stakeholder	Role / responsibility	Interface with the proposal	Areas of concern	Awareness of proposal
Australia)	Australia)		supply (quantity and quality)	
Murray Local Land Services	Catchment manager – Murray catchment NSW	Catchment management	Interface with land assets	Consulted in development of business case
NSW Parks and Wildlife Services	Mid Murrumbidgee wetlands land manager (NSW)	Land manager	Site management implications Achievement of ecological outcomes	Consulted in development of business case
Fisheries NSW	Fishery stock manager	Referral authority for infrastructure upgrade	Creation of backwater Reduction in fish passage, habitat and hydrodynamic diversity	Consulted in development of business case
Yanco Creeks and Tributaries Advisory Council	Local advocate of the Yanco/Billabong system	Representative of creek system users	Water supply to Yanco Billabong system Impacts on environmental condition Flow share management	Consulted in development of business case
Murrumbidgee Customer Service Committee	WaterNSW customer committee	Representative of water users	Flow share management Water supply to Yanco Billabong system	Consulted in development of business case

## 1.1 Feedback on consultation outcomes

The following list outlines the outcome of stakeholder consultation undertaken during the development of this business case. All concerns raised during consultation have been addressed in Section 5 of this business case.

**Murrumbidgee Customer Service Committee:** The Murrumbidgee CSC supported the improvements to water supply level of service to customers through modifications to Yanco weir and Yanco regulator. Representatives expressed concern regarding the impact of the proposed structures on supplementary water access and Yanco Creek system.

**YACTAC:** YACTAC expressed concern about the potential impacts of any exercise that sought to close down the Yanco Creek and re-establish 'natural flows' (i.e. periods of cease to flow). During consultation there was acknowledgement by YACTAC that the intent of the current proposal was not to return the Yanco Creek to a 'natural' flow regime. However, there was unease regarding installation and future management of a structure with the ability to 'shut off' the creek system from the Murrumbidgee (especially during times of prolonged low flow).

Support from YACTAC for the proposal was not forthcoming at this stage of development. Engagement with YACTAC in future project stages (if this supply measure proceeds) is essential to address their water supply concerns adequately. These concerns may be alleviated through the development and implementation of operational rules for Yanco Creek offtake, and/or the formalisation of the temporary diversion channel around Yanco Creek Regulator to provide a permanent source of water to the system.

**Local Land Services:** LLS supported engagement of local community representatives in the development of any proposed changes and emphasised the values of any future environmental flow regime.

**NSW Fisheries:** Fisheries expressed concern regarding the increase in backwater from the proposed Yanco Weir modification, resulting in a reduction in flowing habitat and hydrodynamic diversity in the Murrumbidgee. They also expressed concern regarding the installation of a barrier to fish passage at the Yanco Creek offtake. Consultation with Fisheries has occurred throughout the development of this business case and the potential negative impacts on fish populations have been minimised through adoption of industry best practice for the proposed works.

**Office of Environment and Heritage:** OEHL in the role of environmental water manager was generally supportive of being able to achieve more efficient watering of the mid Murrumbidgee wetlands. However, OEHL expressed concern that this outcome for the mid Murrumbidgee wetlands should not come at the cost of the ecological outcomes of wetlands on the Yanco Creek system. They also expressed a desire for the structures to be operated 'transparently', maintaining currently flow variability in both the Murrumbidgee and Yanco system. The operating rules proposed in this business case have been developed to meet these requirements and address their concerns.

**NSW Parks and Wildlife Services:** As the Mid Murrumbidgee wetlands land manager, NSW Parks and Wildlife Services were supportive of the proposed improvement in watering outcomes for the mid-Murrumbidgee wetlands.

**CEWO:** The Commonwealth Environmental Water Office was supportive of improvements to delivery efficiency to the Mid Murrumbidgee wetlands, providing no detrimental impact to ecological condition of Yanco Creek system.

## 7.3 Further consultation plans

### 7.3.1 Project stages

Four project phases have been identified for the project's engagement with stakeholders. These are:

- Stage 1: SDL adjustment proposal development
  - Phase 1: Preliminary development and documentation
  - Phase 2: Conceptual design and documentation
  - Phase 3: Functional design and documentation
- Stage 2: Approvals and detailed design
- Stage 3: Construction

- Stage 4: Operation and maintenance.

The various phases of the project will require different approaches to engagement with various stakeholder groups. There will be some overlap as the project moves into different phases; and adaptive management will need to be adopted in order to respond to stakeholders needs.

### 7.3.2 Proposed consultation approaches for next phase of project

Further engagement activities and implementation of the Stakeholder Engagement Strategy will continue into the next phase of the project. The strategy will be updated and revised for subsequent phases. An overview of the proposed approach is provided in Table 19.

Table 19. Consultation strategy for the implementation phase

Stakeholder group	Consultation approach	Number/timing
<b>Group 1: Agencies</b>	Intensive engagement with technical experts through Steering Committees Construction and operation progress meetings	Ongoing
<b>Group 2: Landholders and directly impacted stakeholders</b>	Irrigator/adjacent landholder meetings (face-to-face) Special events – site tours (e.g. commencement of construction) Notifications via email, mail or phone as necessary	Ongoing
<b>Group 3: Other community members and groups</b>	Information packages via website (e.g. fact sheets, photos, contact information) Media communication (e.g. media releases, newspaper articles, radio and television interviews) Emails or mail outs if necessary	Ongoing

## 8 Project delivery plan

### 8.1 Operation date for proposal

The expected implementation schedule for the projects is illustrated below (Figure 33). The implementation schedule outlined is highly conservative and includes a significant contingency allowance. The project could be fast-tracked if and as required by SDLAAC. The works will be fully operational prior to 2024.

Stage	Year 1	Year 2	Year 3	Year 4
Business case development	■			
Planning and concept designs	■			
Detailed design phase		■		
Approvals		■	■	
Procurement		■	■	
Construction works			■	■
Commissioning				■

Figure 33. Proposed implementation timeframe for the project

### 8.2 Legal and regulatory requirements

Implementation of the supply measures including i) a new offtake regulator across Yanco creek (including fish-way), ii) raising Yanco concrete(older) fixed crest Old Weir on the Murrumbidgee River, iii) raising Yanco Weir on the Murrumbidgee River and upgrade of the associated operating system and equipment (including fish-way), and iv) an upgrade of the weir pool/storage including control of any escapes and anabranches, will be subject to approvals at Federal, State and Local government levels. The following legislation may be relevant to the project:

- Environment Protection and Biodiversity Conservation Act 1999 (Commonwealth);
- Native Title Act 1995 (Commonwealth);
- Water Act 2007 (Commonwealth);
- NSW Environmental Planning and Assessment Act 1979;
- NSW Crown Lands Act 1989;
- NSW Water Management Act 2000;
- NSW Fisheries Management Act 1994;
- NSW Threatened Species Conservation Act 1995;
- NSW Environmental Planning and Assessment Act 1979; and
- NSW Native Vegetation Conservation Act 2003.

The main considerations for approvals, statutory durations and expected timelines are presented in Table 20 below.

Table 20. Summary of possible Commonwealth and State approvals

Works requiring approval	Approval required	Legislation	Determining Authority
<b>Potential impacts to Matters of National Environmental Significance</b>	Determination under the EPBC Act 1999 if the action constitutes a significant impact to MNES.	Commonwealth Environment Protection and Biodiversity Conservation Act 1999	Commonwealth Department of Environment
<b>All works</b>	Decision on whether or not the project needs to be assessed under Part 3A - State Significant or likely to have significant impacts and thus Environmental Impact Statement.	Environmental Planning and Assessment Act 1979	The Minister
<b>All works</b>	Planning Permit assessment and consent process for the entire project	Environmental Planning and Assessment Act 1979	NSW Planning and Infrastructure
<b>Any proposed activity that will – directly or indirectly – harm an Aboriginal object, or a declared Aboriginal place</b>	Aboriginal Heritage Impact Permit (AHIP)	National Parks and Wildlife Act 1974 (NPW Act)	NSW Office of Environment and Heritage
<b>Any listed threatened or protected flora or fauna potentially impacted upon by project footprint</b>	Permit to harm or remove protected flora or Fauna	NSW Threatened Species Conservation Act 1995 NSW Fisheries Management Act 1994	NSW Office of Environment and Heritage NSW Department of Trade and Investment (NSW Fisheries)
<b>Damage to or clearing of native vegetation</b>	Authority to clear or harm native vegetation	NSW Native Vegetation Conservation Act 2003	NSW Trade and Investment (NSW Local Land Services)
<b>Work and access approvals in relation to water diversions and use</b>	Works associated with control structures, banks regulators	NSW Water Management Act 2000	NSW DPI Water
<b>All works</b>	Public Land Managers Consent	Crown Lands Act 1989	NSW Lands

<b>Creation of easements, licences or leases</b>	Creation of easements, licences or leases across crown land that also relates to any permits or authorities under legislation that relates to the management or regulation of water	Native Title Act 1995
--	---	-----------------------

## 8.2.1 Commonwealth

### 8.2.1.1 Environment Protection and Biodiversity Conservation Act 1999

The EPBC Act applies to developments and associated activities that have the potential to significantly impact on Matters of National Environmental Significance (MNES) protected under the Act. The MNES relevant to the project are summarised below.

Table 21. Summary of Matters of National Environmental Significance relevant to the project

Matter of NES	Project specifics	Comments
<b>Threatened flora species</b>	Two flora species are predicted to occur.	
<b>Threatened fauna species</b>	Twelve fauna species (one amphibian, five birds, four fish and two mammals) have been previously recorded or are predicted to occur.	
<b>Threatened ecological communities</b>	One EPBC Act TEC (Inland Grey Box Woodland) has been recorded near the study area.	
<b>Migratory species</b>	Nine migratory species have been recorded or are predicted to occur.	The study area is unlikely to support an ecologically significant population of any of these species.
<b>Wetlands of international importance (Ramsar sites)</b>	<p>There are five Ramsar sites downstream or in the vicinity of the study area:</p> <ul style="list-style-type: none"> <li>Banrock Station Wetland Complex</li> <li>Coorong and Lakes Alexandrina and Albert</li> <li>Fivebough and Tuckerbil Swamps</li> <li>NSW Central Murray State forests</li> </ul>	<p>Fivebough Swamp is located approx. 30 km north-west of Narrandera, and Tuckerbill Swamp is approx. 35 km north-west of Narrandera.</p> <p>Banrock Station Wetland Complex, Coorong and Lakes Alexandrina and Albert, and Riverland Ramsar sites are located over 500 km downstream of the study area.</p> <p>NSW Central Murray State forests site consists of a large complex of forested wetlands which are approx. 180 km</p>



- Riverland south-west the study area.
- 

An assessment of potentially significant impacts on threatened or migratory species, ecological communities or Ramsar wetlands cannot be undertaken until the infrastructure modernisation project has been refined and thus the implications for the relevant Matters of NES identified and assessed accordingly. A Significant Impact Criteria assessment can then be undertaken for those MNES likely to be impacted by the project.

## **8.2.2 State**

### **8.2.2.1 Environmental Planning and Assessment Act 1979**

The Environmental Planning and Assessment Act 1979 (EP&A Act) was enacted to encourage the proper consideration and management of impacts of proposed development or land-use changes on the environment (both natural and built) and the community. The Act is administered by the NSW Department of Planning. WaterNSW are deemed a determining authority of the EP&A Act under Section 110 of the Act and is has been assumed that the proposal would be assessed under Part 5 of the Act. As such under Section 111 of the Act the determining authority has a duty to consider the environmental impacts of an activity and is required to “take into account to the fullest extent possible all matters affecting or likely to affect the environment” arising from the proposal. WaterNSW would be required to prepare a Review of Environmental Factors (REF) if impacts to the environment are not considered significant.

Sections of the EP&A Act of primary relevance to the natural environment are considered further below in relation to the current proposal.

#### *Assessment of Significance (Section 5A)*

Section 5A of the EP&A Act requires proponents and consent authorities to consider if a development will have a significant effect on threatened biota listed under the TSC Act and FM Act. Section 5A (and Section 9A of the TSC Act) outlines seven factors that must be taken into account in an Assessment of Significance (formally known as the “7-part test”). Where any Assessment of Significance (AoS) determines that a development will result in a significant effect to a threatened biota, a Species Impact Statement (SIS) is required.

The proposed works would alter the hydrological regime of the study area as well as further upstream, which may result in changes to the composition and structure of ecological communities including native vegetation communities and Inland Grey Box Woodland (EPBC Act and TSC Act). The aim of SDL projects is to increase the amount of water available for maintaining and improving ecological values, however overwatering of native vegetation communities and TECs may result in a decline in the quality or extent of these threatened ecological communities.

The need for assessments of significance should be identified during future ecological assessments once the study area has been determined. Refinement of the scope of works within the proposed study area is fundamental to the determination of the impact of significant effects arising from the works. Assessments of significance are not within the scope of the current constraints assessment.

### **8.2.2.2 Threatened Species Conservation Act 1995**

The TSC Act provides for the protection and conservation of biodiversity in NSW through the listing of threatened biota; key threatening processes; and critical habitat for threatened biota.

Native vegetation within the study area may contain threatened biota, or habitat for them. Impacts to the threatened biota must be assessed through the AoS process under Section 5A of the EP&A Act.

Habitat critical to the survival of an endangered or critically endangered species, population or ecological community can be identified under the TSC Act and listed on the Register of Critical Habitat kept by the OEHL.

Refinement of the project requirements needs to be undertaken to determine if any areas of critical habitat may be subject to impacts associated with the proposal.

A licence to harm/pick/damage habitat of a threatened species, population or community or damage critical habitat is unlikely to be required; however the completion of an AoS for each relevant species or ecological community would support the project approval documentation.

#### **8.2.2.3 State Environmental Planning Policies (Part 3 Division 2)**

State Environmental Planning Policies (SEPPs) outline policy objectives relevant to state wide issues. A number of SEPPs are likely to be relevant to the current project and would be identified once the final design is determined.

#### **8.2.2.4 Fisheries Management Act 1994**

The FM Act provides for the protection and conservation of aquatic species and their habitat through NSW. Impacts to threatened biota listed under the FM Act must be assessed through the AoS process under Section 5A of the EP&A Act.

SDL projects are considered to generally benefit native fish species. Provided Fisheries NSW is consulted in regards to the project and appropriate fish passage and flow requirements can be incorporated into the project a permit would not be required.

The proponent for the project will be WaterNSW. As a public authority, the proposal would be permissible without development consent and would be assessed under Part 5 of the EP&A Act (Figure 34).

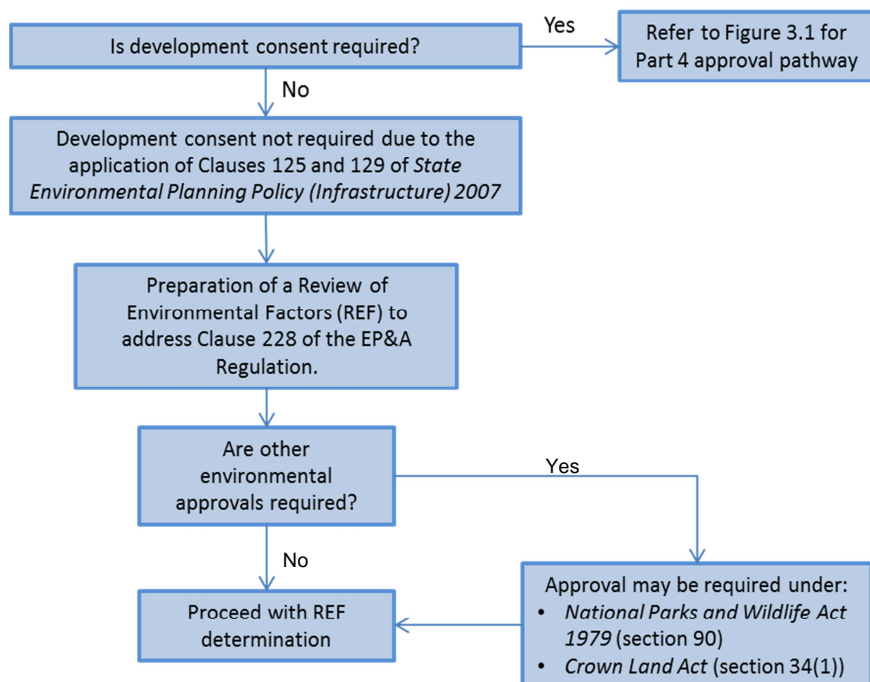

Figure 34. Approvals pathway under Part 5 of the EP&A Act 1979 (GHD 2014b)

The statutory approvals for the project are considered straight-forward for environmental works projects. The construction components will require assessments, consents and approvals – which can take time. This would include a study to assess the potential impacts of the proposal on threatened species and endangered ecological communities listed under the *Threatened Species Conservation Act 1995*, *Fisheries Management Act 1994* and *EPBC Act 1999*. It is anticipated that the proposed works are consistent with legislation outcomes and so should pass without undue delays.

### 8.3 Heritage constraints

The principal means to reduce impacts on heritage values within the study area will be to minimise removal of vegetation and soil in the vicinity of the Murrumbidgee River frontage or areas adjacent to creek systems. As this is not viable in the context of the planned proposals then further assessments will be required to meet the requirements of heritage legislation. Refinement of the project plans with a defined area of construction impact will be required to determine the impacts of the project on heritage values. The key heritage constraints for the study area are:

- The Project contains no AHIMS sites, but river and creek frontages are considered sensitive.
- The Project contains one historical item (Yanco Weir) on NSW Heritage Register and WaterNSW s170 register
- The Project contains two historical items (Yanco Weir and McCaugheys Irrigation area) on Leeton LEP.

The work described in this report cannot proceed without further assessment as the potential of locating Aboriginal sites during the proposed works is assessed as moderate to high. The heritage values of these areas of potential may be at risk of impact from the proposed works. It is recommended that when works are finalised, the works area be subject to further assessment in accordance with the Code of Practice for the archaeological investigation of Aboriginal Objects in New South Wales (OEH 2010).

Listed Heritage items are located within the Study area and will be impacted by the proposed works. Further investigations will be required when works are finalised to determine the impacts on any known historical heritage item. For state listed items a Statement of Heritage Impacts will be required under the NSW Heritage Act 1977 if works are in the immediate vicinity.

All Aboriginal places and objects are protected under the NPW Act. This protection extends to Aboriginal objects and places that have not been identified but might be unearthed during construction. The following contingency plan describes the actions that must be taken in instances where Aboriginal cultural material any such discovery at the study area must follow these steps:

1. Discovery: Should unanticipated Aboriginal cultural material be identified during any works, works must cease in the vicinity of the find.
2. Notification: OEH must be notified of the find.
3. Management: In consultation with OEH, the Local Aboriginal Land Council and a qualified archaeologist, a management strategy should be developed to manage the identified Aboriginal cultural material. This may include the requirement to apply for an Aboriginal Heritage Impact Permit.
4. Recording: The find will be recorded in accordance with the requirements of the National Parks and Wildlife Act 1974 and OEH guidelines.

The following contingency plan describes the actions that must be taken in instances where human remains or suspected human remains are discovered. Any such discovery at the study area must follow these steps:

1. Discovery: If suspected human remains are discovered all activity in the vicinity of the human remains must stop to ensure minimal damage is caused to the remains, and the remains must be left in place, and protected from harm or damage.
2. Notification: Once suspected human skeletal remains have been found, the Coroner's Office and the NSW Police must be notified immediately. Following this, the find must be reported to OEH and it is recommended that it is also reported to the Local Aboriginal Land Council.
3. Management: If the human remains are of Aboriginal ancestral origin an appropriate management strategy will be developed in consultation with Aboriginal Stakeholders and OEH.
4. Recording: The find will be recorded in accordance with the requirements of the National Parks and Wildlife Act 1974 and OEH guidelines.

## 8.4 Legislative and policy amendments and inter-jurisdictional agreements

The current weir pool management terms are included within the water supply works approval. The revised operating rules would require a new works approval to be issued by NSW DPI Water.

Detailed procedures and manuals will need to be updated to reflect the approved rule change. It is expected that these changes will fall within the delegated authority of NSW DPI Water senior officers.

It is not anticipated that there would be any significant legal or regulatory approval barriers to implementation of the proposed supply measures on the Yanco Creek.

## 8.5 Governance and project management

### 8.5.1 Governance arrangements during business case development

Responsibility for the business case development lies with the NSW DPI Water on behalf of the Sustainable Diversion Limit Adjustment Assessment Committee (SDLAAC). Development of the business case has involved close liaison with interested parties including:

- WaterNSW, as the project proponent and the owner of the relevant assets
- NSW DPI Water
- NSW agencies, including NSW Fisheries, NSW Office of Environment and Heritage, NSW National Parks and Wildlife Service and the NSW DPI Water
- YACTAC and the Murrumbidgee Customer Service Committee – the primary interested parties in the Yanco regulator and weir pool adjustment initiatives

### 8.5.2 Governance arrangements during project implementation

The two primary players are NSW DPI Water as the project co-proponent, WaterNSW as the co-proponent, owner and manager of the assets. These partners have a proven track-record of effective project development and implementation.

## 8.6 Monitoring and evaluation

The effectiveness of the proposed supply measure and its operation will be monitored and reported on through WaterNSW's monitoring, evaluation and reporting (MER) strategies and protocols. . These strategies and protocols aim to:

- Establish a robust program logic to define the correlation between works and other inputs and identified outputs and ecosystem outcomes. This provides the basis for a suite of KPIs that are relevant to the specific site
- Monitor progress against those KPIs on a regular basis
- Evaluate the implications of the results for the operational parameters of the scheme, and
- Amend and adjust the operational arrangements to optimise performance and outcomes.

Monitoring data is required to plan weir pool raising and lowering regimes, to manage risks and to refine ecological objectives. The evaluation process involves analysing collected data and improving operations.

A suitable MER approach will be formalised once funding for the supply measure has been confirmed.

The final MER approach for this supply measure will be informed by broader intergovernmental arrangements for Basin-wide monitoring and evaluation under the Basin Plan. This measure is expected to contribute to the achievement of outcomes under two key Chapters of the Plan, namely: (i) under Chapter 8, the delivery of ecological outcomes and (ii) under Chapter 10, meeting the relevant sustainable diversion limit/s (SDLs), which must be complied with under the state's relevant water resource plan/s (WRPs) from 1 July 2019.

---

## 9 References

Alexander, P., D. L. Nielsen & D. Nias, 2008. Response of wetland plant communities to inundation within floodplain landscapes. *Ecological Management & Restoration* 9: 187-195.

Alluvium 2013. Yanco Creek system environmental flows study. Report prepared for State Water by Alluvium Consulting Australia, Melbourne.

Baumgartner, L. J., Reynoldson, N. and Gilligan, D.M. (2006). Mortality of larval Murray cod (*Maccullochella peelii peelii*) and golden perch (*Macquaria ambigua*) associated with passage through two types of low-head weirs. *Marine and Freshwater Research* 57, 181-191.

Baumgartner, L. J. (2007). Diet and feeding habits of predatory fishes upstream and downstream of a low-level weir. *Journal of Fish Biology* 70, 879-894.

Baumgartner, L. J. and Harris, J.H. (2007). Passage of non-salmonid fish through a Deelder lock on a lowland river. *River Research and Applications* 23, 1058-1069.

Boon, P. J., 1988. The impact of river regulation on invertebrate communities in the U.K. *Regulated Rivers: Research & Management* 2: 389-409.

Brock, M. A., D. L. Nielsen, R. J. Shiel, J. D. Green & J. D. Langley, 2003. Drought and aquatic community resilience: the role of eggs and seeds in sediments of temporary wetlands. *Freshwater Biology* 48: 1207-1218.

Casanova, M. T. & M. A. Brock, 2000. How do depth, duration and frequency of flooding influence the establishment of wetland plant communities? *Plant Ecology* 147: 237-250.

CEWO, 2014. Commonwealth environmental water use options 2014–15: Murrumbidgee River Valley, Commonwealth of Australia 2014'.

Clifton, E., 2004, Murrumbidgee Wetland Seedbank Research Project Preliminary Report. Land & Water Project No. NDW32 Improving the management of wetlands on the Murrumbidgee River floodplain, Canberra.

Doeg, T. J., 1984. Response of the macroinvertebrate fauna of the Mitta Mitta River, Victoria, to the construction and operation of Dartmouth Dam. 2. Irrigation release. *Occasional Papers from the Museum of Victoria* 1: 101-108.

Frazier, P. & K. Page 2006. The effect of river regulation on floodplain wetland inundation, Murrumbidgee River, Australia. *Marine and Freshwater Research* 57, 133-141.

Frazier, P., K. Page, J. Louis, S. Briggs & A. Robertson 2003. Relating wetland inundation to river flow using Landsat TM data. *International Journal of Remote Sensing* 24, 3755-3770.

Gilligan, DM. 2002. Fish communities of the Murrumbidgee catchment: Status and trends, NSW Department of Primary Industries - Fisheries Final Report Series No. 75 ISSN 1449-9967

---

---

Gilligan, D. M., 2005. Fish communities of the Murrumbidgee catchment: status and trends. New South Wales Department of Primary Industries: Cronulla Fisheries Centre.

Jones, M and Stuart, I. (2008). Lateral movement of common carp (*Cyprinus carpio*) in a large lowland river and floodplain. *Ecology of Freshwater Fish* 18, 72-82.

Lintermans, M., 2007, *Fishes of the Murray-Darling Basin: an introductory guide*. Murray-Darling Basin Commission, Canberra.

Lyon, J. Stuart, I. Ramsey, D. O'Mahony, J. (2010). The effect of water level on lateral movements of fish between river and off-channel habitats and implications for management. *Marine and Freshwater Research* 61, 271-278.

Mallen-Cooper, M. (1999). Developing fishways for nonsalmonid fishes: a case study from the Murray River in Australia. pp. 173-195 in M. Odeh (ed.). *Innovations in Fish Passage Technology*. (American Fisheries Society: Bethesda, Maryland.)

MDBA 2012. Assessment of environmental water requirements for the proposed Basin Plan: Mid Murrumbidgee River Wetlands, Licensed from the Murray–Darling Basin Authority, under a Creative Commons Attribution 3.0 Australia Licence.

MDBA 2013, Constraints Management Strategy 2013 to 2024. Licensed from the Murray–Darling Basin Authority, under a Creative Commons Attribution 3.0 Australia Licence.

MDBA 2014. 2014–15 Basin Annual Environmental Watering Priorities. Licensed from the Murray–Darling Basin Authority, under a Creative Commons Attribution 3.0 Australia Licence.

NSW Department of Primary Industries (2006) *Reducing the Impact of Weirs on Aquatic Habitat - New South Wales Detailed Weir Review – Murrumbidgee Region*. Report to the Murrumbidgee Catchment Management Authority and the New South Wales Environmental Trust. NSW Department of Primary Industries, Flemington, NSW.

Page, K., A. Read, P. Frazier & N. Mount, 2005. The effect of altered flow regime on the frequency and duration of bankfull discharge: Murrumbidgee River, Australia. *River Research and Applications* 21: 567-578.

Sharpe, C. and Stuart, I. (2015). *The Distribution of Trout Cod in Yanco and Colombo Creeks*. Final Report for Murray Local Land Services by CPS Enviro and Kingfisher Research, Irymple Victoria.

Sharpe, C., Stuart, I. and Vilizzi, L (2013). *Billabong, Yanco and Colombo Creek Fish Baseline Project 2012-13*. Draft Report, for Murray Catchment Management Authority by CPS Environmental Research.

Sheldon, F., A. J. Boulton & J. T. Puckridge, 2002. Conservation value of variable connectivity: aquatic invertebrate assemblages of channel and floodplain habitats of a central Australian arid-zone river, Cooper Creek. *Biological Conservation* 103: 13-31.

Stuart, I. G. Zampatti, B. P. and Baumgartner, L. J. (2008). Can a low-gradient vertical-slot fishway provide passage for a lowland river fish community? *Marine and Freshwater*

---



---

Wassens, S. Watts, R.J., Howitt, J., Spencer, J., Zander, A. and Hall, A. (2011) Monitoring of ecosystem responses to the delivery of environmental water in the Murrumbidgee system. Institute for Land, Water and Society. Report 1

Wassens, S., 2006. Frog communities of the Murrumbidgee Irrigation Area, NSW In Taylor, I. R., P. A. Murray & S. G. Taylor (eds.), *Wetlands of the Murrumbidgee River Catchment: Practical Management in an Altered Environment*. Fivebough and Tuckerbil Wetlands Trust, Leeton, NSW: 86-95.

Wassens, S. & M. Maher, 2011. River regulation influences the composition and distribution of inland frog communities. *River Research and Applications* 27: 238-246.

Wassens, S. & C. Amos, 2011, *Assessing the resilience of frog communities within River Red Gum forest*. New South Wales Office of Environment and Heritage, Sydney.

Wassens, S., R. J. Watts, A. Jansen & D. Roshier, 2008. Movement patterns of southern bell frogs (*Litoria raniformis*) in response to flooding. *Wildlife Research* 35: 50-58.

Wassens, S., A. Hall, W. Osborne & R. J. Watts, 2010. Habitat characteristics predict occupancy patterns of the endangered amphibian *Litoria raniformis* in flow-regulated flood plain wetlands. *Austral Ecology* 35: 944-955.

Watts, R. J., D. S. Ryder, A. Burns, A. Zander, A. L. Wilson & R. Dehaan. 2008. Monitoring of a pulsed release in the Mitta Mitta River, Victoria, during the bulk water transfer from Dartmouth Dam to Hume Dam 2007-08. Institute for Land Water and Society Report No. 45.

Watts, R. J., D. S. Ryder & C. Allan, 2009, *Environmental monitoring of variable flow trials conducted at Dartmouth Dam, 2001/02-07/08 - Synthesis of key findings and operational recommendations*. Charles Sturt University ILWS Report No. 50. , Albury, NSW.

Watts, R. J., A. Zander, A. Burns & C. Allan. 2011. *Environmental monitoring of pulsed releases from Dartmouth Dam to the Mitta Mitta River in 2009/2010*. Report to the Murray Darling Basin Authority. Charles Sturt University, Institute for Land Water and Society Report Number 63, Albury.

---

## Appendix 1. Summary of response to the Phase 2 Assessment Guidelines

This section confirms how this business case delivers against each of the relevant requirements of the SDLAAC Phase 2 Assessment Guidelines. The following table lists the requirements and then records where the issue is dealt with in this business case.

Table 22. Concordance - SDLAAC Phase 2 Assessment Guidelines and Business Case

Guidelines Section	Heading	Requirement	Business Case Section
3.1	Supply measure definition	Defines the requirements for supply measures to: <ul style="list-style-type: none"> <li>operate to increase the quantity of water</li> <li>achieve equivalent environmental outcomes with a lower volume of water</li> <li>have no detrimental impacts</li> </ul>	1.3
3.1.2	Measures not included in the benchmark conditions of development	Confirm that the measure was not in the benchmark conditions of development	1.4, 1.7
3.2	Constraint measure requirements	Defines application of guidelines to constraint measure initiatives	Not applicable to this business case
3.3	Operational by June 2024	The measure must be capable of entering into operation by 30 June 2024	8.1
3.4.1	The measure is a 'new measure'	Confirm the measure has not received funding or have funding approved	1.7

Guidelines Section	Heading	Requirement	Business Case Section
3.4.2	Compliance with the purposes of the Water for the Environment Special Account	Defines funding eligibility for constraint measure initiatives	Not applicable to this business case
4.1	Project details	Key project details and overview	2
4.2	Ecological values of the site	Description of the ecological values of the site	2.5, 2.6
4.3	Ecological objectives and targets	Confirm objectives and targets	2.5
4.4.1	Anticipated ecological benefits	Proposed outcomes from the investment	4.1
4.4.2	Potential adverse ecological impacts	Assessment of potential adverse impacts	5.4, 5.5, 5.6
4.5.1	Current hydrology and proposed changes	Clear articulation of current and proposed hydrology	2.4, 3.3
4.5.2	Environmental water requirements	Water requirements of new inundated areas	2.5.1
4.6	Operating regime	Explanation of the role of each operating scenario	3.3
4.7	Risks and impacts from operation	Assessment of risks and mitigation options	5
4.8	Technical feasibility and fitness for purpose	Evidence that the project infrastructure is technically feasible	6
4.9	Complementary actions and interdependencies	Confirm interaction with other initiatives	2.3
4.10	Costs, Benefits and Funding Arrangements	Detailed costing and listing of benefits	3.4
4.11.1	Stakeholder management strategy	Stakeholder management strategy	7
4.11.2	Legal and regulatory requirements	Legal and regulatory requirements	8.2
4.11.3	Governance and project management	Governance and project management	8.5
4.11.4	Risks from project development and delivery	Risks from project development and delivery	8

---

## Appendix 2

### Yanco Creek environmental flow achievement under proposed conditions

#### Reach 1 results

##### Baseflows

The achievement of the baseflow recommendations for Reach 1 under the benchmark, current and pre-development flow regimes (~~Table 23~~~~Table-23~~) indicates that while the baseflow recommendation was rarely achieved prior to river regulation, it is achieved all the time under the benchmark and proposed management arrangements. The proposal does not affect the ability to provide baseflow recommendations.

Table 23. *Reach 1 – Achievement of baseflow recommendations under benchmark and proposed conditions*

Period	Pre-development (percent of years)	Benchmark (percent of years)	Proposed (percent of years)
Jan-Apr (lower flow season)	1%	100%	100%
May-Dec (higher flow season)	6%	100%	100%

##### Fresh, bankfull and overbank events

~~Figure 35~~~~Figure-35~~ shows the number of events that occur in each year (during the specified flow period) for each fresh, bankfull or overbank flow recommendation; ~~Figure 36~~~~Figure-36~~ shows the duration of each event (fresh, bankfull or overbank) for all years. These results are provided for both the benchmark (shown as bars) and proposed (shown as shaded area) conditions - the recommended number and duration of events is also shown as a red line on the graphs. The number and duration of these events over the entire period is also summarised all in ~~Table 24~~~~Table-24~~ and ~~Table 25~~~~Table-25~~.

~~Figure 35~~~~Figure-35~~ and ~~Table 24~~~~Table-24~~ show overall moderate compliance under the benchmark flow regime with the recommended number of environmental flow freshes - the recommended number of freshes are achieved in 44% – 59% of years. Bankfull and overbank events are achieved more frequently under the benchmark, at 82% to 100% of target years respectively. Under the proposal, the number of freshes, bankfull and overbank events are maintained.

~~Figure 36~~~~Figure-36~~ and ~~Table 25~~~~Table-25~~ show that the duration of the freshes, bankfull and overbank events is very often in accordance with the environmental flow recommendations under both the benchmark and proposed flow regime - these events exceed the recommended duration for 85-100% of events.

The proposal therefore retains the ability to provide freshes, bankfull and overbank flows at the duration and frequency found under the benchmark.

---

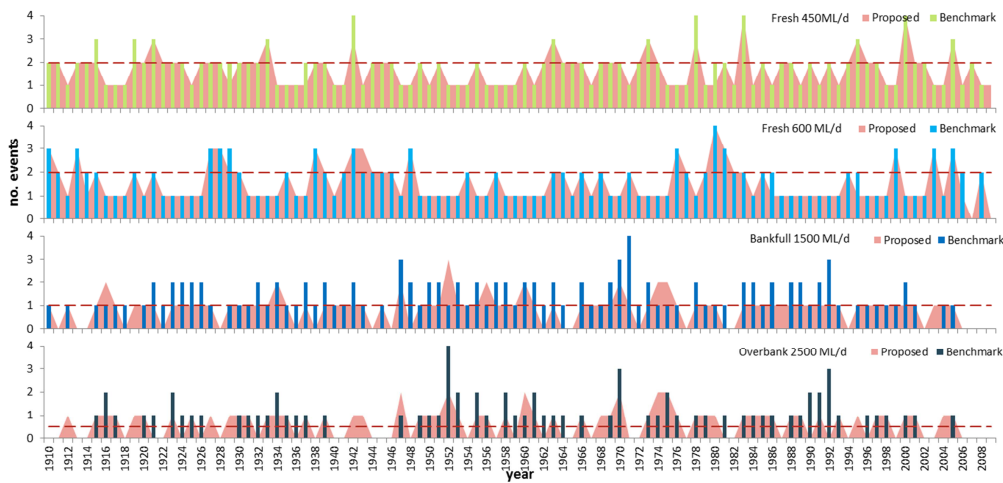

Figure 35. Reach 1 – Number of events achieved each year

Table 24. Reach 1 – Percentage of years in the flow record that the recommended number of events is achieved

Event	Benchmark (percent of years)	Proposed (percent of years)
Fresh 450 ML/d (target 2 events / period)	59%	56%
Fresh 600 ML/d (target 2 events / period)	44%	40%
Bankfull 1500 ML/d (target 1 event / period)	82%	76%
Overbank 2500 ML/d (target 1 event every second year)	>100% of target years	>100% of target years

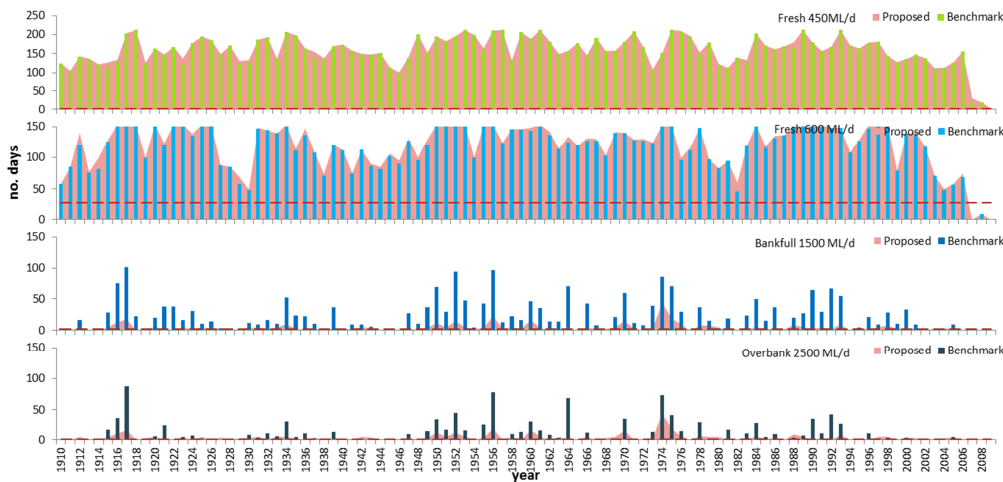

Figure 36. Reach 1 – Total duration of flows above recommended rate each year

Table 25. Reach 1 – Percentage of target events achieved that persist for the recommended duration

Event	Benchmark (percent of events)	Proposed (percent of events)
Fresh 450 ML/d (target 1 day duration)	100%	100%

Event	Benchmark (percent of events)	Proposed (percent of events)
Fresh 600 ML/d (target 14 day duration)	85%	86%
Bankfull 1500 ML/d (target 2 day duration)	98%	99%
Overbank 2500 ML/d (target 2 day duration)	92%	97%

## Reach 2 results

### Baseflows

The achievement of the baseflow recommendations for Reach 2 under the benchmark, current and pre-development flow regimes ([Table 26](#)) indicates that while the baseflow recommendation was rarely achieved prior to river regulation, it is achieved more than half the time under the benchmark and proposed management arrangements. The proposal does not affect the ability to provide baseflow recommendations.

Table 26. Reach 2 – Achievement of baseflow recommendations under benchmark and proposed conditions

Period	Pre-development (percent of years)	Benchmark (percent of years)	Proposed (percent of years)
Jan-Apr (lower flow season)	1%	54%	56%
May-Dec (higher flow season)	6%	76%	76%

### Fresh, bankfull and overbank events

[Figure 37](#) shows the number of events that occur in each year (during the specified flow period) for each fresh, bankfull or overbank flow recommendation; [Figure 37](#) shows the duration of each event (fresh, bankfull or overbank) for all years. These results are provided for both the benchmark (shown as bars) and proposed (shown as shaded area) conditions - the recommended number and duration of events is also shown as a red line on the graphs. The number and duration of these events over the entire period is also summarised all in [Table 27](#) and [Table 28](#).

[Figure 38](#) and [Table 27](#) show overall moderate to good compliance under the benchmark flow regime with the recommended number of 350 ML/d freshes, bankfull and overbank events. The frequency of the 250 ML/d fresh is much less than desired, only being fully achieved in 7% of years. The proposal retains much the same frequency of these events, with the exception of a major improvement in the frequency of the 350 ML/d fresh, but a slight decline in the frequency of bankfull events.

[Figure 38](#) and [Table 28](#) show that the duration of the 250 ML/d fresh, bankfull and overbank events is very often in accordance with the environmental flow recommendations under both the benchmark and proposed flow regime - these events exceed the recommended duration for 84-100% of events. The compliance of the duration of the 350 ML/d fresh is lower, and under the benchmark, the required 14 day duration of the 350 ML/d fresh only occurs in 65% of events. The proposal results in a further decline in event duration, to provide the required duration for 52% of events. Bankfull events also experience a slightly reduced frequency under the proposal.

The proposal therefore retains the ability to provide freshes and overbank events at a similar frequency and duration to that occurring under the benchmark. The proposal also provides a vast improvement in the frequency of the 350 ML/d fresh, but the duration of 350 ML/d

freshes declines by about 13%. The proposal also has a slight adverse impact on the frequency and duration of the bankfull event.

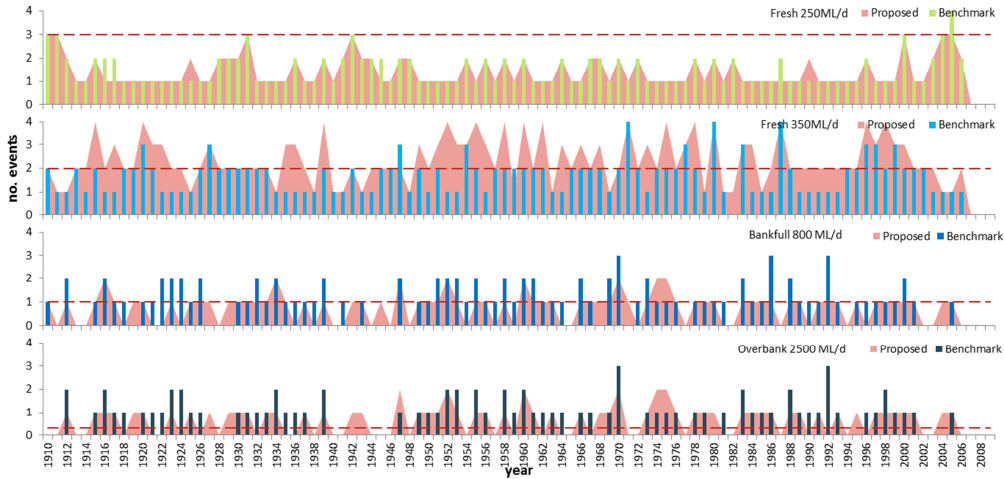

Figure 37. Reach 2 – Number of events achieved each year

Table 27. Reach 2 – Percentage of years in the flow record that the recommended number of events is achieved

Event	Benchmark (percent of years)	Proposed (percent of years)
Fresh 250 ML/d (target 3 events / period)	7%	7%
Fresh 350 ML/d (target 2 events / period)	55%	79%
Bankfull 800 ML/d (target 1 event / period)	73%	66%
Overbank 1000 ML/d (target 1 event every third year)	>100% of target years	>100% of target years

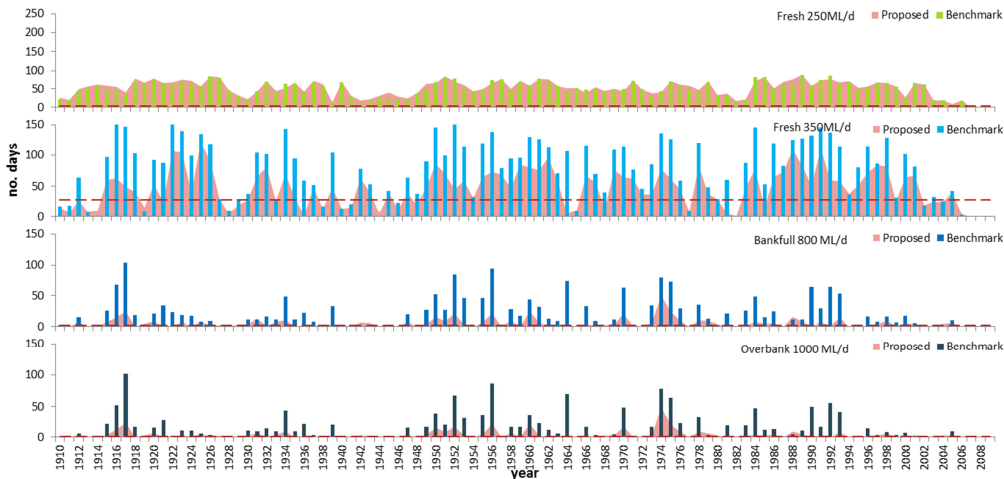

Figure 38. Reach 2 – Total duration of flows above recommended rate each year

Table 28. Reach 2 – Percentage of target events achieved that persist for the recommended duration

Event	Benchmark (percent of events)	Proposed (percent of events)
Fresh 250 ML/d (target 1 day duration)	100%	100%
Fresh 350 ML/d (target 14 day duration)	65%	52%
Bankfull 800 ML/d (target 2 day duration)	94%	84%
Overbank 1000 ML/d (target 2 day duration)	94%	95%

## Reach 3 results

### Baseflows

The achievement of the baseflow recommendations for Reach 3 under the benchmark, current and pre-development flow regimes (~~Table 29~~~~Table-29~~) indicates that while the baseflow recommendation was rarely achieved prior to river regulation, it is always achieved under the benchmark and proposed management arrangements. The proposal does not affect the ability to provide baseflow recommendations.

Table 29. Reach 3 – Achievement of baseflow recommendations under benchmark and proposed conditions

Period	Pre-development (percent of years)	Benchmark (percent of years)	Proposed (percent of years)
Sept-May (55 ML/d)	4%	100%	100%
Sept-May (105 ML/d)	4%	100%	100%

### Overbank events

Note, this reach has no recommended fresh or bankfull events, so the following analysis is based on the overbank flow recommendation only.

~~Figure 39~~~~Figure-39~~ shows the number of events that occur in each year (during the specified flow period) for the overbank flow recommendation; ~~Figure 40~~~~Figure-40~~ shows the duration of each overbank event for all years. These results are provided for both the benchmark (shown as bars) and proposed (shown as shaded area) conditions - the recommended number and duration of events is also shown as a red line on the graphs. The number and duration of these events over the entire period is also summarised all in ~~Table 30~~~~Table-30~~ and ~~Table 31~~~~Table-31~~.

~~Figure 39~~~~Figure-39~~ and ~~Table 30~~~~Table-30~~ show overall good compliance under the benchmark flow regime with the recommended number of overbank events, with it occurring in 80% of target years. However, the proposal results in an overall decrease in the number of overbank events that occur in this reach, from 80% to 60% of target years.

~~Figure 40~~~~Figure-40~~ and ~~Table 31~~~~Table-31~~ show that the duration of the overbank events is very often in accordance with the environmental flow recommendations under both the benchmark and proposed flow regime – there is a slight improvement under the proposal.

The proposal therefore maintains the ability to provide overbank events at the target duration, but does result in an overall decrease in the number of overbank events that occur in this reach.



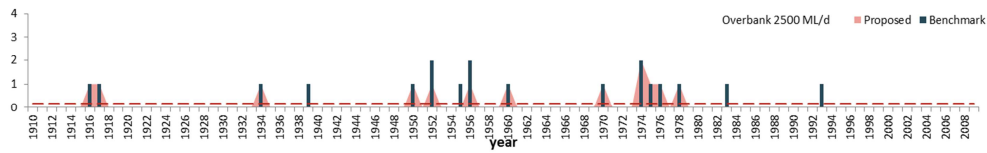

Figure 39. Reach 3 – Number of events achieved each year

Table 30. Reach 3 – Percentage of years in the flow record that the recommended number of events is achieved

Event	Benchmark (percent of years)	Proposed (percent of years)
Overbank 1600 ML/d (target 2 events every ten years)	80% of target years	60% of target years

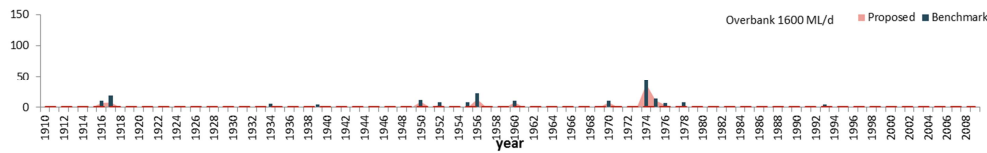

Figure 40. Reach 3 – Total duration of flows above recommended rate each year

Table 31. Reach 3 – Percentage of target events achieved that persist for the recommended duration

Event	Benchmark (percent of events)	Proposed (percent of events)
Overbank 6000 ML/d (target 4 day duration)	84%	85%

---

## Reach 4a results

### Baseflows

The achievement of the baseflow recommendations for Reach 4a under the benchmark, current and pre-development flow regimes ([Table 32](#)~~Table 32~~) indicates that while the baseflow recommendation was rarely achieved prior to river regulation, it is achieved 67-100% of the time under the benchmark management arrangements. The frequency of success is retained under the proposal. The proposal does not affect the ability to provide baseflow recommendations.

Table 32. Reach 4a – Achievement of baseflow recommendations under benchmark and proposed conditions

Period	Pre-development (percent of years)	Benchmark (percent of years)	Proposed (percent of years)
Sept-Apr (lower flow season)	4%	100%	100%
May-Aug (higher flow season)	7%	67%	67%

### Fresh, bankfull and overbank events

[Figure 41](#)~~Figure 41~~ shows the number of events that occur in each year (during the specified flow period) for each fresh, bankfull or overbank flow recommendation; [Figure 42](#)~~Figure 42~~ shows the duration of each event (fresh, bankfull or overbank) for all years. These results are provided for both the benchmark (shown as bars) and proposed (shown as shaded area) conditions - the recommended number and duration of events is also shown as a red line on the graphs. The number and duration of these events over the entire period is also summarised all in [Table 33](#)~~Table 33~~ and [Table 34](#)~~Table 34~~.

[Figure 41](#)~~Figure 41~~ and [Table 33](#)~~Table 33~~ show overall poor compliance with the frequency of freshes of 250 ML/d and 300 ML/d under the benchmark flow regime, but much better compliance with the recommended number of 700 ML/d freshes, bankfull and overbank events. The frequency of these three larger events under the benchmark varies from 88% to more than 100% of target years. The proposal largely retains the frequency of fresh and overbank events, although does result in a slightly reduced frequency of the bankfull event.

[Figure 42](#)~~Figure 42~~ and [Table 34](#)~~Table 34~~ show the duration of the fresh and overbank events are largely retained under the proposal, but there is an increase in the duration of bankfull events.

The proposal therefore retains the frequency and duration of the freshes and overbank events, while the bankfull event sees a slight decrease in frequency but an increase in duration.

---

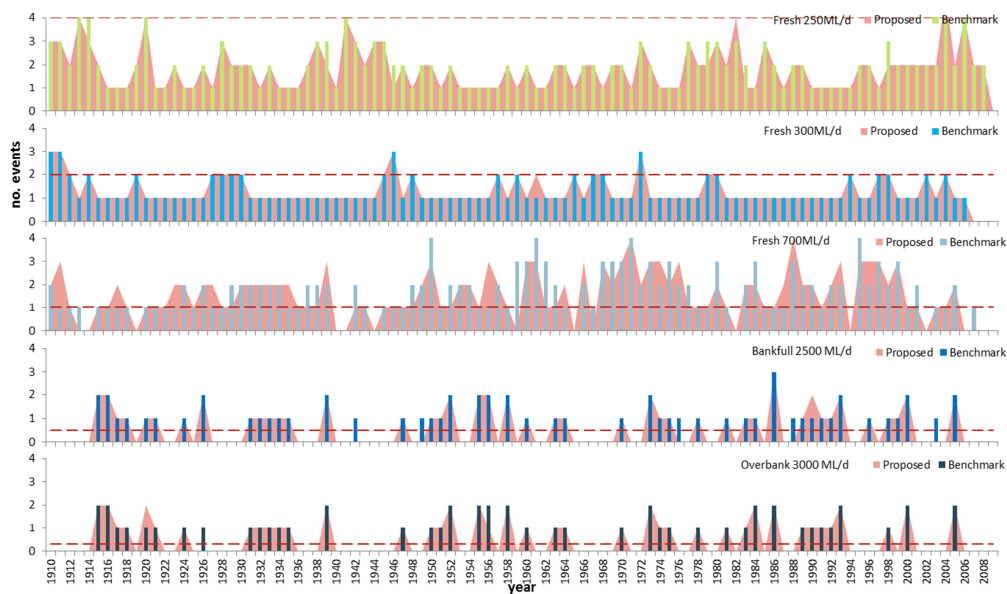

Figure 41. Reach 4a – Number of events achieved each year

Table 33. Reach 4a – Percentage of years in the flow record that the recommended number of events is achieved

Event	Benchmark (percent of years)	Proposed (percent of years)
Fresh 250 ML/d (target 4 events / period)	6%	6%
Fresh 300 ML/d (target 2 events / period)	25%	26%
Fresh 700 ML/d (target 1 event / period)	88%	84%
Bankfull 2500 ML/d (target 1 event every second year)	96%	86%
Overbank 3000 ML/d (target 1 event every third year)	>100% of target years	>100% of target years

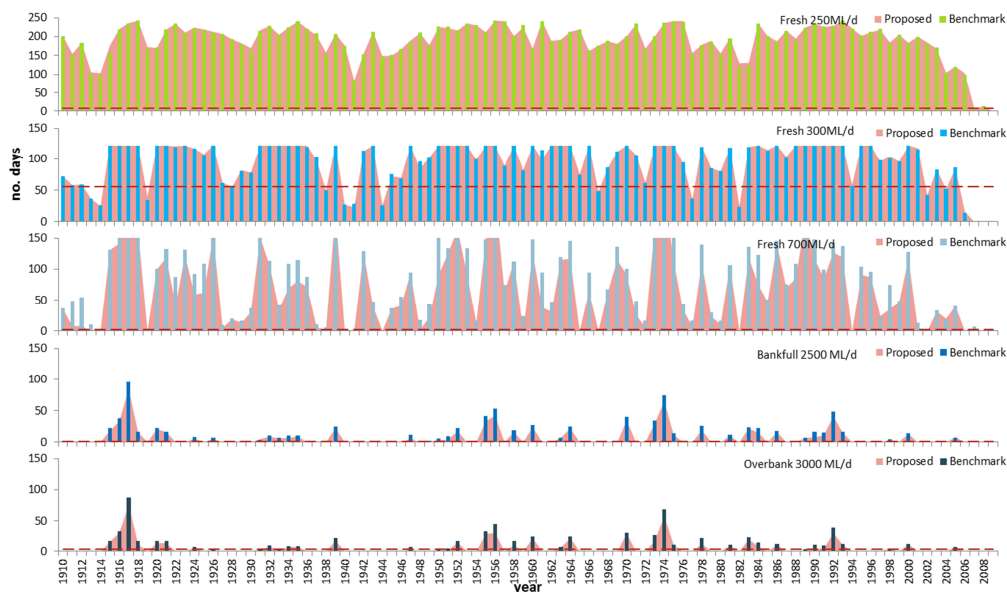

Figure 42. Reach 4a – Total duration of flows above recommended rate each year

Table 34. Reach 4a – Percentage of target events achieved that persist for the recommended duration

Event	Benchmark (percent of events)	Proposed (percent of events)
Fresh 250 ML/d (target 2 day duration)	96%	97%
Fresh 300 ML/d (target 28 day duration)	75%	74%
Fresh 700 ML/d (target 2 day duration)	96%	95%
Bankfull 2500 ML/d (target 2 day duration)	90%	95%
Overbank 3000 ML/d (target 10 day duration)	43%	38%

## Reach 5 results

### Baseflows

The achievement of the baseflow recommendations for Reach 5 under the benchmark, current and pre-development flow regimes (Table 35) indicates that the baseflow recommendations were almost always achieved prior to river regulation, and continue to be satisfactorily achieved under both the benchmark and proposal. The proposal does not affect the ability to provide baseflow recommendations.

Table 35. Reach 5 – Achievement of baseflow recommendations under benchmark and proposed conditions

Period	Pre-development (percent of years)	Benchmark (percent of years)	Proposed (percent of years)
Jan-Apr (lower flow season)	100%	100%	100%
May-Dec (higher flow season)	99%	99%	99%

### Fresh, bankfull and overbank events

Figure 43 shows the number of events that occur in each year (during the specified flow period) for each fresh, bankfull or overbank flow recommendation; Figure 44 shows the duration of each event (fresh, bankfull or overbank) for all years. These results are provided for both the benchmark (shown as bars) and proposed (shown as shaded area) conditions - the recommended number and duration of events is also shown as a red line on the graphs. The number and duration of these events over the entire period is also summarised all in Table 36 and Table 37.

Figure 43 and Table 36 show overall moderate to good compliance under the benchmark flow regime with the recommended number of 700 ML/d freshes, bankfull and overbank events. The frequency of the 200 ML/d fresh is never successfully achieved under the benchmark regime, as the durations of spells above the threshold are very long – in some cases most of the season. The proposal sees a small decline in the frequency of the 700 ML/d fresh (reducing from 91-95%) and bankfull (reducing from 65-56%) events, while the frequency of the other events is maintained.

Figure 44 and Table 37 show that the duration of the freshes, bankfull and overbank events is very often in accordance with the environmental flow recommendations under both the benchmark and proposed flow regime - these events exceed the recommended duration for 88-99% of events.

The proposal therefore largely retains the ability to provide freshes, bankfull and overbank events at a similar frequency and duration to that occurring under the benchmark, with the exception of a slightly reduced frequency of the 700 ML/d fresh and bankfull events.

It is worth noting that the failure of the number of 200 ML/d events target is because the durations of spells above the threshold are very long – in some cases most of the season – therefore while the durations are complied with the number of events is less so.

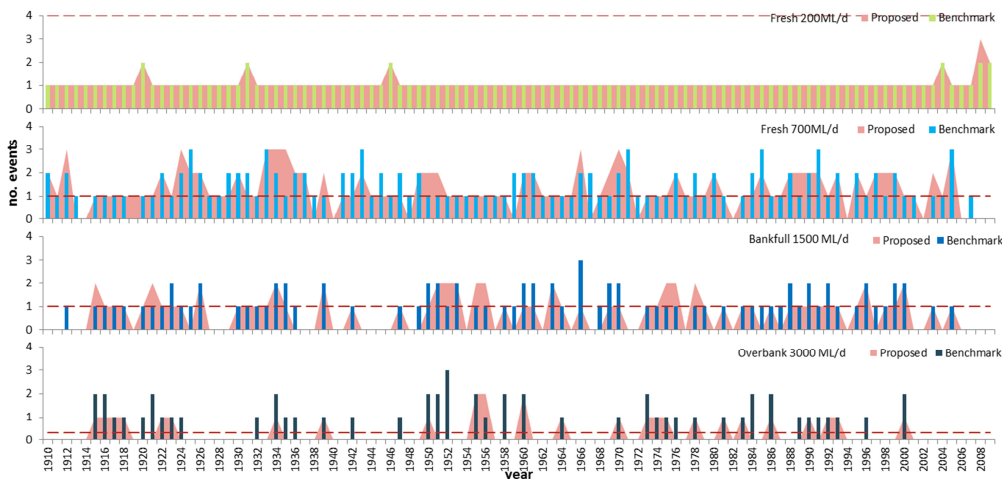

Figure 43. Reach 5 – Number of events achieved each year

Table 36. Reach 5 – Percentage of years in the flow record that the recommended number of events is achieved

Event	Benchmark (percent of years)	Proposed (percent of years)
Fresh 200 ML/d (target 4 events / period)	0%*	0%*
Fresh 700 ML/d (target 1 event / period)	91%	85%
Bankfull 1500 ML/d (target 1 event / period)	65%	56%
Overbank 3000 ML/d (target 1 event every third year)	96% of target years	93% of target years

\* Percentage of years for 200 ML/d is so low as events tend to occur only once each season, but last entire season

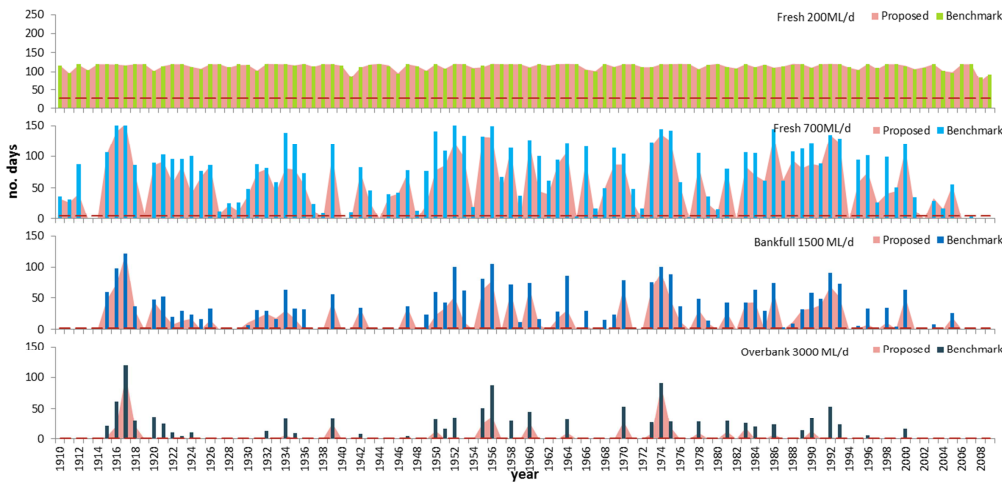

Figure 44. Reach 5 – Total duration of flows above recommended rate each year

Table 37. Reach 5 – Percentage of target events achieved that persist for the recommended duration

Event	Benchmark (percent of events)	Proposed (percent of events)
Fresh 200 ML/d (target 7 day duration)	99%	98%
Fresh 700 ML/d (target 5 day duration)	88%	90%
Bankfull 1500 ML/d (target 2 day duration)	98%	96%
Overbank 3000 ML/d (target 2 day duration)	96%	93%

## Reach 6 results

### Baseflows

The achievement of the baseflow recommendations for Reach 6 under the benchmark, current and pre-development flow regimes (~~Table 38~~ ~~Table 38~~) indicates that while the baseflow recommendation was rarely achieved prior to river regulation, the winter baseflow is achieved more than three-quarters of the time under the benchmark and proposed management arrangements while the summer base flow is achieved almost half the time. The proposal does not affect the ability to provide baseflow recommendations.

**Table 38. Reach 6 – Achievement of baseflow recommendations under benchmark and proposed conditions**

Period	Pre-development (percent of years)	Benchmark (percent of years)	Proposed (percent of years)
Jan-Apr (lower flow season)	1%	46%	45%
May-Dec (higher flow season)	7%	78%	77%

**Fresh and overbank events**

Note, this reach has no recommended bankfull events, so the following analysis is based on the two fresh and overbank flow recommendation only.

Figure 45 shows the number of events that occur in each year (during the specified flow period) for each fresh and overbank flow recommendation; Figure 46 shows the duration of each event (fresh or overbank) for all years. These results are provided for both the benchmark (shown as bars) and proposed (shown as shaded area) conditions - the recommended number and duration of events is also shown as a red line on the graphs. The number and duration of these events over the entire period is also summarised all in Table 39 and Table 40.

Figure 45 and Table 39 show overall very good compliance under the benchmark flow regime with the recommended number of 100 ML/d freshes. However, 800 ML/d freshes and overbank events occur at a much less frequent interval than desired. The proposal provides each of these events at much the same frequency as under the benchmark.

Figure 46 and Table 40 show that the duration of the 100 ML/d fresh and overbank events is very often in accordance with the environmental flow recommendations under both the benchmark and proposed flow regime - these events exceed the recommended duration for 86-100% of events. The compliance of the duration of the 800 ML/d fresh is much lower, with the required 14 day duration of the 800 ML/d fresh only occurs in 47% and 44% of events for the benchmark and proposal respectively.

The proposal therefore retains the ability to provide freshes and overbank events at a similar frequency and duration to that occurring under the benchmark.

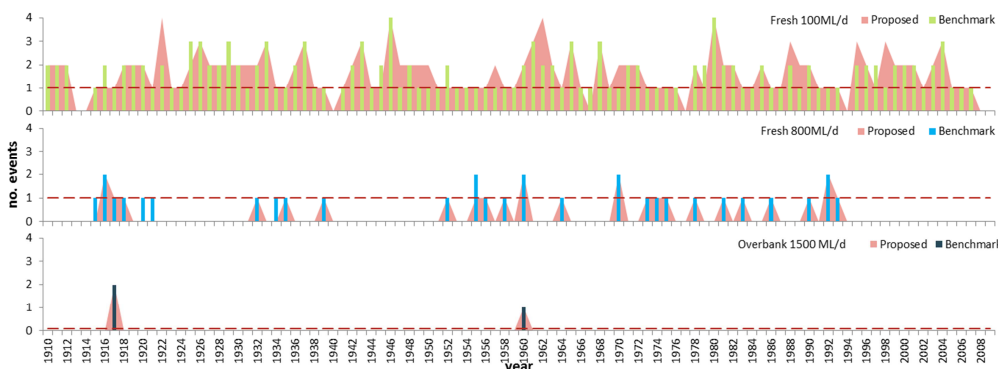

**Figure 45. Reach 6 – Number of events achieved each year**

**Table 39. Reach 6 – Percentage of years in the flow record that the recommended number of events is achieved**

Event	Benchmark (percent of years)	Proposed (percent of years)
Fresh 100 ML/d (target 1 event / period)	93%	92%
Fresh 800 ML/d (target 1 event / period)	27%	23%
Overbank 1500 ML/d (target 1 event every ten years)	20% of target years	20% of target years

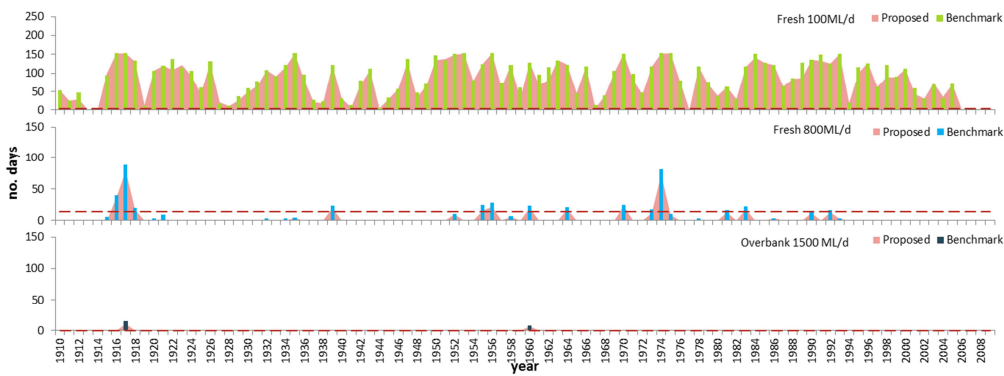

**Figure 46. Reach 6 – Total duration of flows above recommended rate each year**

**Table 40. Reach 6 – Percentage of target events achieved that persist for the recommended duration**

Event	Benchmark (percent of events)	Proposed (percent of events)
Fresh 100 ML/d (target 4 day duration)	88%	86%
Fresh 800 ML/d (target 14 day duration)	47%	44%
Overbank 1500 ML/d (target 2 day duration)	100%	100%



---

**Appendix 3.**  
**Preliminary ecological constraints assessment**  
**Desktop heritage constraints assessment**

---

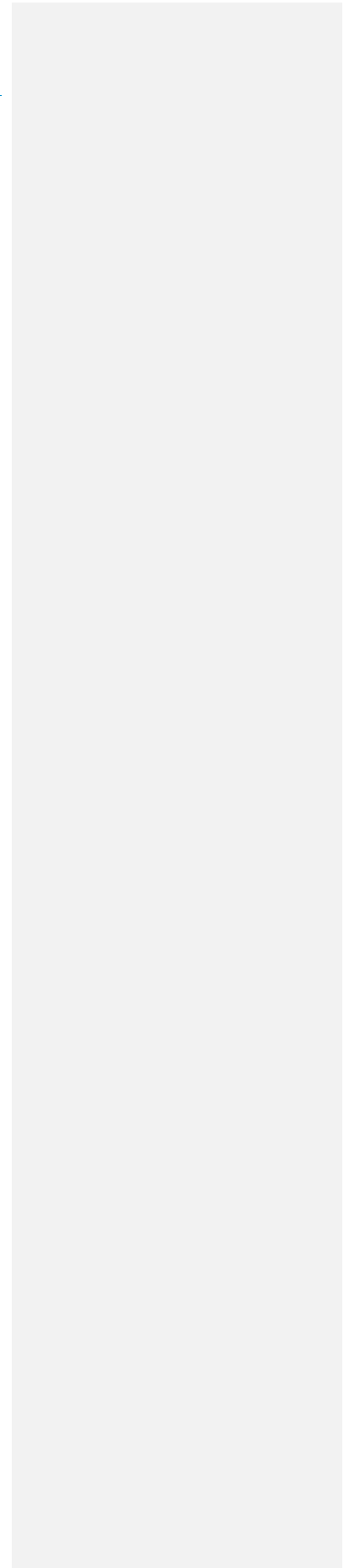

---

## Appendix 4. Fish ecology report

### Murrumbidgee River and Yanco Creek fish community

The mid-Murrumbidgee River and Yanco Creek are within the range of at least 15 native fish species (Gilligan 2005; Table 1). In the mainstem of the Murrumbidgee River there are strong populations of golden perch, silver perch, freshwater catfish, Trout Cod and Murray cod. There is spawning and self-sustaining populations of the majority of these fish (Baumgartner 2007; Baumgartner and Harris 2007; Jason Thiem, pers. com.). In Yanco Creek, there is also a Trout Cod population but it is unclear whether these fish form a self-sustaining population or are reliant on spawning in the mainstem of the Murrumbidgee system (Sharpe et al. 2013; Sharpe and Stuart 2014).

Small-bodied fish are also common, as they are elsewhere in the lowlands of the Murrumbidgee River catchment and these include Australian smelt, carp gudgeons, Murray-Darling rainbowfish, flatheaded gudgeons and unspotted hardyhead. The very uncommon small-bodied fish include: southern purple spotted gudgeon, southern pygmy perch, olive perchlet and flatheaded galaxias but these are not expected to be present in the Yanco Weir project area.

Spangled perch, lampreys and freshwater eels are very uncommon in this area of the Murray-Darling Basin. Macquarie perch might also occur in the Murrumbidgee River below the township of Wagga Wagga but would likely be in very low numbers.

### Broad fish movement patterns

Low and rising flows are important for upstream migration of native fish species and the fish which can be expected to migrate at low flows are identified in Table 1. Fish which can be expected to migrate upstream during high flows, particularly in spring are also shown and the seasonal timing is summarised in Table 2. Although no fish species migrate upstream exclusively on high flows, some fish like golden perch, silver perch and Murray cod are highly mobile during floods (100s km). Downstream migration is also an important component of the life-history of most of the native fish species. Late winter, spring and summer are the important times for upstream and downstream fish movement. Some fish appear to make more localised movements (metres) for feeding and these include river blackfish and to a slightly lesser extent freshwater catfish.

The early life stages of fish also drift downstream with golden perch, Murray cod, Trout Cod and potentially silver perch eggs and larvae present in spring and summer.

### Movement to-and-from Yanco Creek

Fish movement to-and-from Yanco Creek is important for the local population ecology and will occur for almost all fish species but especially for freshwater catfish and Trout Cod. This reasons for this movement include for feeding, dispersal, gene flow and re-colonisation.

Trout Cod are most common in the upper part of Yanco Creek, usually above Tarabah Weir while freshwater catfish and golden perch are found through the system (Sharpe et al. 2013). Large-bodied fish species (e.g. Murray cod and Trout Cod) will generally stay in the deeper pools, with strong habitat values and water velocities (i.e. >0.3 m/s). All fish species

---

---

are more likely to use Yanco Creek in spring and summer rather than winter, unless flow and permanent pools are maintained. There is also likely to be drift of native fish eggs and larvae into Yanco Creek during spring and summer.

Small-bodied fish will be permanent residents in Yanco Creek though there is likely to be some exchange with the Murrumbidgee (Lyon et al. 2010). Yanco Creek supports the most robust native fish community while there is flow through the system and strong connectivity with the Murrumbidgee River.

In summary the major expected trends in fish movements are:

- **CATEGORY 1: Large-bodied native fish** (Murray cod, Trout Cod and potentially freshwater catfish):
    - Adult fish will move upstream and downstream in the Murrumbidgee River, mainly from mid-winter to the end of spring and early summer.
    - Some adult fish will move between Yanco Creek and Murrumbidgee River with fish entering in spring and leaving when water levels fall at the end of the irrigation season. However, there is likely to be constant exchange of fish during spring and summer.
      - Fish will be strongly cued to move by rising or falling water levels (e.g. 150-200 mm/day).
      - More adult fish will move at medium and high flows, including floods
    - Larvae will be swept under Yanco Weir during spring/summer, where mortality rates will be high (Baumgartner et al. 2006). Larvae will drift into Yanco Creek where there will likely be a low level of recruitment.
    - Juveniles and sub-adults will likely move upstream and downstream at Yanco Weir in spring and summer, some fish will also move in and out of Yanco Creek. Juvenile fish will move at low, medium and high flows.
  - **CATEGORY 2: Medium-bodied native fish** (mainly golden perch and silver perch and possibly bony herring)
    - Adult fish will migrate upstream and downstream in spring and summer and especially during a river rise and flooding (Mallen-Cooper 1999).
    - Eggs and larvae will drift downstream in spring and summer where there is high mortality associated with under-shot weir gate passage. Larvae will drift into Yanco Creek where there will be little or no recruitment.
    - Juveniles migrate upstream, especially from mid/late-spring and summer though few appear to actively enter Yanco Creek.
  - **CATEGORY 3: Small-bodied native fish** (mainly carp gudgeons, Australian smelt and Murray-Darling rainbowfish and unspotted hardyhead)
    - Adult fish will migrate in the Murrumbidgee River throughout spring and summer and to-and-from Yanco Creek (see Stuart et al. 2008 for an example in the lower Murray River; Lyon et al. 2010).
    - Larvae will drift under the Yanco Weir gates and into Yanco Creek.
-

---

➤ Juveniles will likely inhabit and complete their life-histories in Yanco Creek.

• **CATEGORY 4: Non-native fish**

➤ Adult fish, particularly carp, will migrate in the Murrumbidgee River from spring to autumn and use fishways (Jones and Stuart 2008). Some fish will also enter Yanco Creek.

➤ Larvae, particularly of carp, will enter Yanco Creek in spring and summer. Some larvae will be spawned in Yanco Creek.

➤ Juveniles will reside in Yanco Creek and grow to adults.

## Ecological Priorities

The local ecological priorities are to:

- Maintain and improve connectivity of habitats along the mainstem of the Murrumbidgee River and Yanco Creek
- Maintain and improve regional populations of medium and large bodied fish, including golden perch, silver perch, Trout Cod, Murray cod and freshwater catfish
- Enhance the survival of all life stages of fish that migrate downstream at Yanco Weir and at the proposed Yanco Creek regulator

## Priority Fish Passage Objectives

The Murrumbidgee River and Yanco Creek support a valuable native fish community. The recommended design philosophy for fish passage at Yanco Weir (Murrumbidgee River) and at the proposed new Yanco Creek Weir is to provide fish passage at low and medium flow events up to the drown-out level of the weir.

The objectives from this approach are therefore to:

- 1) Provide safe downstream passage of eggs, larvae, juvenile and adult fish.
- 2) Provide upstream passage of medium and large-bodied fish (60-1000 mm long; Category 1 & 2) over a wide range of flows, including high flows.
- 3) Improve habitat connectivity for Category 1 & 2 fish that migrate at macro (100s km) and meso (10s km) scales

Hence, the fishway design should be based on fish biology and hydraulically cater for a variety of fish behaviours and especially medium/large fish (Category 1 & 2) which require continuous attraction flow and traditionally pass more efficiently through pool-type fishways than locks.

## Risks

➤ The major risk in accepting this model is that the fishways do not specifically cater for small bodied common fish (<60 mm long), including carp gudgeons, flatheaded gudgeons, Australian smelt, Murray rainbowfish and unspotted hardyhead .

---

**Table 1.** The fish community which occurs in the Murrumbidgee River. H=high flow, M=medium flow, L=low flow. \*Unlikely indicates fish species that once occurred in the Murrumbidgee catchment but have not been recorded in the last 20-30 years. # indicates a species with conservation significance. Scale of movement is micro (<100 metres), meso (100s to 10s km) macro (100s km).

Medium and large-bodied fish CATEGORY 1 & 2	Common name	Murrumbidgee River	Yanco Ck	Usual maximum size	Juvenile migration	Migration river flow	Scale of movement
<i>Macquaria ambigua</i>	Golden perch	✓	✓	600 mm	Yes	H,M,L	macro
<i>Bidyanus bidyanus</i> #	Silver perch	✓	✓	500 mm	Yes	H,M,L	macro
<i>Leipotherapon unicolor</i>	Spangled perch	Unlikely	Unlikely	300 mm	Yes	H,M	macro
<i>Gadopsis marmoratus</i>	River blackfish	Possible	Unlikely	350 mm	Unknown		meso
<i>Maccullochella peelii</i> #	Murray Cod	✓	✓	1200 mm	Yes	H,M,L	macro
<i>Maccullochella macquariensis</i> #	Trout Cod	✓	✓	700 mm	Yes	H,M,L	meso
<i>Tandanus tandanus</i>	Eel-tailed catfish	✓	✓	800 mm	Unknown		meso
<i>Macquaria australasica</i> #	Macquarie perch	Possible	Unlikely	400 mm	Unknown		meso
<i>Anguilla</i> spp.	Freshwater eels	Unlikely	Unlikely	1000 mm	Yes	H,M,L	macro
<i>Mordacia mordax</i>	lamprey	Unlikely	Unlikely	500 mm	Yes	M,L	macro
<i>Nematalosa erebi</i>	Bony herring	✓y	✓	400 mm	Yes	H,M,L	macro
<b>Small-bodied fish (&lt;100 mm long)</b> CATEGORY 3							
<i>Hypseleotris</i> spp	Carp gudgeons	✓	✓	45 mm	Yes	M,L	micro
<i>Craterocephalus stercusmuscarum</i>	Unspecked hardyhead	✓	✓	80 mm	Yes	M,L	micro
<i>Galaxias olidus</i>	Mountain galaxiids	Unlikely	Unlikely	100 mm	unknown		meso
<i>Galaxias rostratus</i>	Flat-headed galaxias	Possible	Possible	100 mm	unknown	unknown	meso
<i>Philypnodon grandiceps</i>	Flat-head gudgeon	✓	✓	90 mm	unknown		micro

<i>Philypnodon sp. 1</i>	Dwarf flat-headed gudgeon	✓	✓	50 mm	Unknown		micro
<i>Retropinna semoni</i>	Australian smelt	✓	✓	100 mm	Yes	M,L	micro
<i>Melanotaenia fluviatilis</i>	Murray rainbow fish	✓	✓	90 mm	Yes	M,L	micro
<i>Ambassis aqassizi</i> #	Olive perchlet	*Unlikely	*Unlikely	60 mm	Unknown	unknown	micro
<i>Mogurnda adspersa</i> #	Southern purple spotted gudgeon	*Unlikely	*Unlikely	100 mm	Unknown	unknown	micro
<i>Nannoperca australis</i> #	Southern pygmy perch	*Unlikely	*Unlikely	80 mm	Unknown	unknown	micro
<b>Non-native fish CATERGORY 4</b>							
<i>Carassius auratus</i>	Goldfish	✓	✓	300 mm	Yes	M,L	
<i>Cyprinus carpio</i>	Common carp	✓	✓	800 mm	Yes	H,M,L	
<i>Gambusia holbrooki</i>	Gambusia	✓	✓	60 mm	Yes	M,L	
<i>Tinca tinca</i>	tench	Unlikely	Unlikely	400 mm	Unknown		
<i>Perca fluviatus</i>	Redfin perch	✓	✓	400 mm	Yes	M,L	
<i>Salmo trutta</i>	Brown trout	✓	Possible	800 mm	Yes	M,L	
<i>Misgurnus anguillicaudatus</i>	Oriental weatherloach	Possible	Possible	200 mm	Unknown		

**Table 2.** The timing of fish migrations in the Yanco Weir area of the mid Murrumbidgee River system.

		WINTER	SPRING	SUMMER	AUTUMN
<b>NATIVE</b>					
<b>Large-bodied (500-1000 mm)</b>	Adult		—————	—————	.....
	Juvenile		—————	—————	.....
	Murray cod		—————	—————	
Trout Cod	Adult		.....	.....	.....
	Juvenile		.....	.....	.....
	Larvae		—————	—————	
<b>Medium-bodied (90-500 mm)</b>	Adult		—————	—————	.....
	Juvenile		—————	—————	.....
	Golden perch, silver perch		.....	—————	
Bony herring	Adult		—————	—————	.....
	Juvenile		—————	—————	.....
	Larvae		—————	—————	
Freshwater catfish, river blackfish, Macquarie perch	Adult		.....	.....	.....
	Juvenile		.....	.....	.....
	Larvae				
<b>Small-bodied (20-90 mm)</b>	Adult	—————	—————	—————	.....
	Juvenile		—————	—————	.....
	Australian smelt		—————	—————	
Carp gudgeons, flat-headed gudgeon	Adult			—————	.....
	Juvenile			—————	.....
	Larvae			—————	
Unspecked hardyhead	Adult			—————	.....
	Juvenile			—————	.....
	Larvae			—————	
Pygmy perch, flat-headed galaxias, olive perchlet, southern purple-spotted gudgeon, dwarf flat-headed gudgeon, Murray hardyhead			.....	.....	.....
<b>NON-NATIVE</b>					
Carp	Adult		.....	.....	.....
	Juvenile		.....	.....	.....
	Larvae		—————	—————	
Redfin perch, oriental weatherloach, Eastern gambusia, goldfish			.....	.....	.....

---

## References

- Baumgartner, L. J., Reynoldson, N. and Gilligan, D.M. (2006). Mortality of larval Murray cod (*Maccullochella peelii peelii*) and golden perch (*Macquaria ambigua*) associated with passage through two types of low-head weirs. *Marine and Freshwater Research* **57**, 181-191.
- Baumgartner, L. J. (2007). Diet and feeding habits of predatory fishes upstream and downstream of a low-level weir. *Journal of Fish Biology* **70**, 879-894.
- Baumgartner, L. J. and Harris, J.H. (2007). Passage of non-salmonid fish through a Deelder lock on a lowland river. *River Research and Applications* **23**, 1058-1069.
- Gilligan, D. (2005). Fish communities of the Murrumbidgee catchment: status and trends. NSW Department of Primary industries report. 138 pp.
- Jones, M and Stuart, I. (2008). Lateral movement of common carp (*Cyprinus carpio*) in a large lowland river and floodplain. *Ecology of Freshwater Fish* **18**, 72-82.
- Lintermans, M. (2009). Fishes of the Murray-Darling Basin: An Introductory Guide. MDBC Publication. 157 pp.
- Lyon, J. Stuart, I. Ramsey, D. O'Mahony, J. (2010). The effect of water level on lateral movements of fish between river and off-channel habitats and implications for management. *Marine and Freshwater Research* **61**, 271-278.
- Mallen-Cooper, M. (1999). Developing fishways for nonsalmonid fishes: a case study from the Murray River in Australia. pp. 173-195 in M. Odeh (ed.). *Innovations in Fish Passage Technology*. (American Fisheries Society: Bethesda, Maryland.).
- Sharpe, C., Stuart, I. and Vilizzi, L (2013). Billabong, Yanco and Colombo Creek Fish Baseline Project 2012-13. Draft Report, for Murray Catchment Management Authority by CPS Environmental Research.
- Sharpe, C/ and Stuart, I. (2014). The distribution of Trout Cod in Yanco and Columbo creeks. Final report for Murray Local Land Services. CPS Enviro and Kingfisher Research.
- Stuart, I. G. Zampatti, B. P. and Baumgartner, L. J. (2008). Can a low-gradient vertical-slot fishway provide passage for a lowland river fish community? *Marine and Freshwater*



---

**Appendix 5. Key issues workshop minutes**

# Murrumbidgee SDLA – Project models

22 March 2016

## 1 Project model overview

This report describes:

- The project model cases that have been developed
- How the models were developed from the Adjusted Benchmark model
- Key assumptions

The MDBA's Benchmark model was altered to produce an Adjusted Benchmark model (see note *Murrumbidgee SDLA – Update of Benchmark Model*, DHI, 2016). The Adjusted Benchmark was then changed to include the proposed SDLA projects for the Murrumbidgee. These include:

- Water for Rivers projects post 2009 (tripartite projects including CARM)
- Yanco Colombo Billabong modernisation project
- Yanco Offtake project
- Nimmie Caira project
- Yanga National Park project

Individual project models were produced for each of the above, as well as a combined overall model including all projects.

## 2 Project model development

### 2.1 Water for Rivers projects post 2009 (tripartite works)

This project includes a number of sub-projects which were carried out under the tripartite agreement between NSW Office of Water, Water for Rivers and State Water. These include:

- Wilson Anabranh and associated losses
- Beavers Creek existing offtake structure, and losses and return flows on the Beavers / Old Man Creek system
- Augmented supply via Irrigation Corporations:
  - Coleambally Irrigation Area escape drain operation and historical loss provision, and
  - Murray Irrigation Finley Escape drain operation,
- Oak and Gras Innes Wetland losses on Bundidgerry Creek
- Tributary utilisation for regulated orders (for CARM)
- Yanco Offtake operation (for CARM)
- Rainfall rejection from Murrumbidgee Irrigation (for CARM)

Prior to adding these tripartite projects, the Adjusted Benchmark model had been produced to allow better representation of these changes between the Benchmark and the post-project case. These changes are outlined in *Murrumbidgee SDLA – Update of Benchmark Model* (DHI, 2016).

The tripartite projects were added to the Adjusted Benchmark model to produce the post-project Tripartite works model. The significant changes to the model included:

- Wilson anabranch: adding a regulator that opens and closes the anabranch inlet on a seasonal basis, and change of the outlet relationship to reflect the outlet gate being left permanently open
- Beavers Creek / Old Man Creek: Replacement of the old weir structure with new gates, with these operated on a seasonal basis, and including some supplementary flow sharing; addition of the Dog Fall and Old Old Man Creek anabranch structures;; addition of the seasonal minimum flow target at the end of Old Man Creek
- Coleambally Irrigation Area Drains: Change of the ordering priority through Yanco Offtake, to provide a minimum 50 ML/d through offtake, then to supply all additional Yanco Creek orders through the CI drains until they are at full capacity
- Murray Irrigation Finley Escape: Change of operation to alter drains flows in respond to orders at Puckawidgee, with this reducing orders being passed up Billabong Creek to the Yanco Offtake
- Oak Creek and Gras Innes Regulators (Bundidgerry): Removal of these wetland areas from the creek, to represent supply from environmental water volumes as required
- CARM tributary utilisation: change of the “available flow to use for orders” time series, with more flow now available than in the Adjusted Benchmark, to reflect better tributary forecasting
- CARM Yanco Offtake Operation: Reduction of the seasonal oversupply factor through Yanco Offtake from 1.25 to 1.20, to reflect improved operational information on Yanco Billabong under CARM
- CARM rainfall rejection: Reduction of orders into MI Main Canal at Berembred in response to rainfall to represent improved river forecasting capacity under CARM (Benchmark only reduces extractions, not orders)

These changes are implemented in the model BIDGDA3.sqj.

As part of the tripartite agreement, licences were granted to Water for Rivers for the water savings produced by these projects. These included a 20,000 unit share High Security licence and a 13,000 unit share General Security licence. These licences have been added into the post-project model, and are placed in the model at two dummy irrigation nodes immediately downstream of Blowering Dam (one for General Security and one for High Security licences). These are the same nodes used to represent the pre-2009 Water for Rivers projects in the Adjusted Benchmark, with the licence volumes increased to include the additional tripartite projects licence.

The increased utilisation of Finley Escape also increases the volume coming through into the Murrumbidgee Valley from the Murray. This additional volume has to be returned to the Murray to ensure there is no net change in the intervalley trade balance. This is done in the model by adding a dummy irrigation node downstream of Balranald. This node orders and diverts a long-term average amount that is the same as the increase in Finley Escape outflow. This dummy node effectively sets aside water from the allocation to restore the IVT balance.

The addition of the projects also reduces the surplus flows within the system, including reducing end of system flows at Balranald and Moulamein. In the model, this reduction in surplus flow is linked to a reduction in dam releases, as unnecessary releases are reduced. This produces an increase in storage in the model, and an associated increase in allocations occurs. In the version of the post-project model provided, the allocation is allowed to increase, and there are no specific nodes calling this retained surplus out of the dams.

The projects also reduces the long-term average inflow to Lowbidgee by approximately 2,800 ML/yr compared to the Adjusted Benchmark case. This reduction has not been

restored in the post-CARM case, as the combined model includes diversion into Nimmie Caira and Yanga to satisfy environmental inundation targets.

## 2.2 Yanco Colombo Billabong modernisation project

This project includes a number of modifications to the Yanco Colombo Billabong system, as outlined in the Effluents Business Case. These include:

- DC800: Increase of the capacity of the Coleambally Irrigation drain DC800 from 50 ML/d to 100 ML/d
- Lower Yanco Weir: A new weir to re-regulate flows
- Colombo Weirs: Addition of re-regulation structures on Colombo Creek, at 8 Mile, Chesneys Weir, Cocketdegong and Coonong Weir (these are modelled as one combined weir in the model)
- Murray Irrigation Berrigan Escape: Supply of up to 100 ML/d through Berrigan Escape in response to orders. This is done in the model based on the remaining order upstream of Finley Escape, though maintaining a minimum 60ML/d in the creek upstream of Berrigan Escape
- Hartwood Weir: Reconstruction of the weir to include re-regulation storage
- Downstream of Yanco and Billabong confluence: A new weir to re-regulate flows
- Wanganella: A new weir to re-regulate flows
- Piccanniny diversion: Extraction of surplus flows at the end of Forest Creek, and diversion of these through Piccanniny Creek back into Billabong Creek
- Existing structures on Billabong Creek at Algudgerie and on Mid Yanco Creek: Lowering of these fixed crest structures to reduce losses

These changes are implemented in the model BIDGEA9.sqj.

The utilisation of Berrigan Escape increases the volume coming through into the Murrumbidgee Valley from the Murray, as was noted for the tripartite works projects for Finley Escape. This additional Berrigan Escape volume also has to be returned to the Murray to ensure there is no net change in the intervalley trade balance. The dummy irrigation node downstream of Balranald created to balance the tripartite Finley Escape additional flow is adjusted in the model to balance the combined increase in both Finley and Berrigan Escapes.

The re-regulation structures in the model are represented using in-line storages. These storages accumulate excess discharge. When the weir has reached a threshold stored volume, it reduces the order being passed upstream by the amount it has stored. It subsequently releases this on the appropriate day to supply the downstream order.

Existing fixed crest structures on the Mid-Yanco and at Algudgerie on Billabong Creek are modelled as time series of evaporation losses. Different time series are used for the Adjusted Benchmark and post-project models.

## 2.3 Yanco Offtake project

This project involves construction of a regulator on Yanco Offtake, as described in the *Business Case: Yanco Offtake SDL Adjustment Supply Measure* (Alluvium, XXX). The changes to the Adjusted Benchmark model are in the model BIDGMFE6.sqj

The offtake itself is implemented in the model by adding a control structure in the model, with an assumed maximum diversion capacity for the structure.

The approach in the Benchmark model to surplus flow sharing between the Murrumbidgee River and Yanco Creek is changed in the post-project model. The surplus flow diversion is determined by a new time series that specifies large diversions into Yanco Creek, in order to achieve bankfull and overbank flows within the creek system. This is specified in the Yanco Offtake Business Case.

The post-project model also includes a minimum flow time series downstream of the Yanco Offtake. This minimum flow aims to preserve the flow regime in the creek when river flows are less than 15,000 ML/d. It does this by extracting the Benchmark time series of discharges through the offtake for river flows < 15,000 ML/d, and adding this as minimum flow node referring to the extracted time series.

## 2.4 Yanga National Park 1AS regulator project

This project is described in the *Business Case: Murray and Murrumbidgee Valley National Parks SDL Adjustment Supply Measure* (Alluvium, October 2015). One of the measures proposed by this project is reconstruction of the Yanga 1AS regulator. The Business Case estimates this leaks water from the river into Yanga National Park at an average rate of approximately 5,400 ML/yr.

To model this the river loss between Maude Weir and Redbank Weir was changed. The loss rate in the benchmark model is a constant 55 ML/d for all flows greater than 55ML/d. This was reduced to 40 ML/d in the post-project model (which is equivalent to an annual volume of 5,400 ML as flows do not fall below the 55 ML/d threshold).

The changes to the Adjusted Benchmark model are in model BIDGFA2.sqq.

## 2.5 Nimmie Caira – Yanga National Park project

This project is described in the *Business Case: Nimmie-Caira SDL Adjustment Supply Measure* (Alluvium, XXX). The Business Case identifies target environmental water volumes inside Nimmie – Caira and Yanga National Park, which should be achieved on a target inter-annual frequency.

The project is modelled by diverting additional volumes out of the river to try and achieve these target volumes. Targets differ for different cases - the four cases considered were:

- Nimmie Caira with no rehabilitation: Target environmental volumes based on Nimmie Caira requirements, without any rehabilitation works of the floodplain inside Nimmie Caira having been carried out (i.e. current configuration)
- Nimmie Caira with rehabilitation: Target environmental volumes based on Nimmie Caira requirements, with rehabilitation works of the floodplain inside Nimmie Caira having been carried out
- Nimmie Caira and Yanga National Park with no rehabilitation: Target environmental volumes based on both Nimmie Caira and Yanga National Park requirements, without any rehabilitation works of the floodplain inside Nimmie Caira having been carried out (i.e. current configuration)
- Nimmie Caira and Yanga National Park with rehabilitation: Target environmental volumes based on both Nimmie Caira and Yanga National Park requirements, with rehabilitation works of the floodplain inside Nimmie Caira having been carried out

The targets specified in the business case were simplified in order to make them assessable in the model. The set of targets applied in the model were:

[Table 1 Nimmie Caira and Yanga environmental water volume targets](#)

Case	Model Name	Supply Measure (GL) achieved in percentile of years			
		95% tile	50% tile	40% tile	14% tile
Nimmie Caira (no Rehab)	BIDGA02	3	46	192	302
Nimmie Caira (with Rehab)	BIDGA03	3	46	290	414
Yanga and Nimmie Caira (no rehab)	BIDGA04	26	46	248	664
Yanga and Nimmie Caira (with Rehab)	BIDGA05	26	46	346	774

In order to apply these targets in the model, the following approach was used:

- Years in which SFI targets at Maude Weir are met in the model are identified – this is taken as an indicator that sufficient flow may be available to divert water into Nimmie Caira / Yanga to reach a watering target event
- The volume of environmental water already diverted into Lowbidgee is calculated from the Benchmark model run
- The additional volume required to reach the target is then worked out in a spreadsheet; this is done for each of the four target columns in Table 1
- The additional volume required for the four targets is disaggregated into a daily diversion series, based on the time series of surplus flows available according to the Benchmark run results
- The resulting time series is set as a diversion series in the project model
- The project model is run, and it is checked whether the target volumes are achieved, and whether the frequency of reaching these volumes is within the range specified in the business case

The project model is modified from the Adjusted Benchmark model. It includes an additional Lowbidgee floodplain storage that is separate to the “bucket” storages in the benchmark model. All additional discharge to meet the target event volume is diverted into the separate floodplain bucket.

Furthermore, it is assumed that none of the additional diverted flow to meet the environmental targets returns to the Murrumbidgee River. It is assumed that the entire volume is retained within Lowbidgee and eventually lost to the system.

### 3 Combined project model

The combined model includes all of the individual SDLA project model changes. As there are four different Nimmie-Caira and Yanga National Park cases, there are four different versions of the combined project model file, as outlined in Table 2.

Table 2 Combined project model files

Case	Model Name
Nimmie Caira (no Rehab)	BIDGCA2
Nimmie Caira (with Rehab)	BIDGCA3
Yanga and Nimmie Caira (no rehab)	BIDGCA4
Yanga and Nimmie Caira (with Rehab)	BIDGCA5

The key issues and assumptions regarding the combined model are summarised here:

- The models do not include nodes to utilise any water “produced” by the projects, instead any gain will result in an increased long-term allocation in the model
- Changes to Finley and Berrigan escapes increase the amount of water diverted from the Murray into Billabong Creek, and a dummy irrigation node downstream of Balranald is used to balance the IVT
- The water savings licences associated with the tripartite projects (including CARM) are included in the model, and are added to dummy irrigation nodes situated immediately downstream of Blowering Dam (these nodes also include the pre-2009 Water for Rivers project licences)
- There is a small decrease in Lowbidgee diversions in the post-CARM model (2.8 GL/yr), however the combined model includes the Nimmie-Caira environmental targets which override this
- Yanco Offtake is modelled with a fixed low flow regime, which is based on the MDBA Benchmark model discharge time series through the offtake (instead of specific low flow targets at the offtake)

DRAFT

DRAFT





FINAL REPORT:

Yanco Creek system environmental flows study

May 2013

## Document history

### Revision:

Revision no. 06  
Author/s



Checked  
Approved

### Distribution:

Revision no. 06  
Issue date 23 May 2013  
Issued to  
Description: Final report

### Citation:

Alluvium (2013), *Yanco Creek system environmental flow study (final report)*, report prepared by Alluvium Consulting Australia for State Water, Leeton NSW.

### Acknowledgements:

This study was managed by Amanda Wealands (Alluvium) and conducted by a Technical Panel comprising:

Dom Blackham	Geomorphology
Paul Boon	Vegetation and wetlands
Tim Doeg	Macroinvertebrates
Darcy Moar	Hydrology and hydraulics
Clayton Sharpe	Fish
Ivor Stuart	Fish

The project team would like to thank and acknowledge the input to this project from [redacted] (State Water project manager), and the project Steering Committee:

[redacted]	NSW Office of Water
[redacted]	Landholder
[redacted]	Murray CAM
[redacted]	State Water
[redacted]	DPI Fisheries
[redacted]	CEWO
[redacted]	Private consultant
[redacted]	Murrumbidgee CMA
[redacted] chair)	YACTAC
[redacted]	OEH

We would also like to acknowledge and thank the following people for involvement in the Technical Panel field inspection:

- [redacted]
- [redacted]
- [redacted]
- [redacted]

# Contents

<b>1</b>	<b>Introduction</b>	<b>3</b>
1.1	Background to the study	3
1.1.1	Scope	3
1.2	Method	4
1.3	Study area	5
	Study reaches	5
	Environmental flows study sites	7
1.4	The Final Report (this report)	8
<b>2</b>	<b>Yanco Creek system</b>	<b>10</b>
2.1	Overview	10
2.2	Water resource development and management	11
	Available environmental water	12
2.3	Water resource plans	13
	Murrumbidgee Water Sharing Plan	13
	Annual Environmental Watering Plans	14
2.4	System characteristics	15
	Hydrology	15
	Physical form	21
	Water dependent vegetation	22
	Floodplain wetlands	24
	Fish	24
	Macroinvertebrates	25
<b>3</b>	<b>Environmental objectives</b>	<b>27</b>
3.1	Maintain and/or rehabilitate riparian vegetation condition, extent and composition	28
	Description	28
	Relevant reaches	28
	Flow objectives	28
3.2	Maintain diversity and abundance of instream vegetation	30
	Description	30
	Relevant reaches	30
	Flow objectives	30
3.3	Maintain a mosaic of wetlands	30
	Description	30
	Relevant reaches	31
	Flow objectives	31
3.4	Maintain channel form and promote habitat diversity	33
	Description	33
	Relevant reaches	33
	Flow objectives	33
3.5	Maintain drought refuge habitat	34
	Description	34
	Relevant reaches	35
	Flow objectives	35
3.6	Support self sustaining populations of macroinvertebrate taxa from the endangered Lower Murray Aquatic Ecological Community and those found in mid-Murrumbidgee wetlands	36
	Description	36
	Relevant reaches	36

	Flow objectives	36
3.7	Maintain and improve large and medium-bodied native fish community	36
	Description	36
	Relevant reaches	37
	Flow objectives	37
3.8	Maintain small-bodied generalist native fish community	39
	Description	39
	Relevant reaches	39
	Flow objectives	39
3.9	Maintain small-bodied native fish – floodplain specialists	40
	Description	40
	Relevant reaches	40
	Flow objectives	41
<b>4</b>	<b>Environmental flow recommendations</b>	<b>42</b>
4.1	Approach to determining environmental flows	42
	Environmental flow assessment sites	42
	Hydraulic modelling	43
4.2	Reach 1: Upper Yanco Creek	46
	Summary – environmental values	47
	Reach 1 environmental objectives	49
	Reach 1 environmental flow recommendations	50
	Reach 1 Performance and risk assessment	51
4.3	Reach 2: Mid Yanco Creek	55
	Summary – environmental values	56
	Reach 2 environmental objectives	57
	Reach 2 environmental flow recommendations	58
	Reach 2 performance and risk assessment	59
4.4	Reach 3: Colombo Creek	63
	Summary – environmental values	63
	Reach 3 environmental objectives	65
	Reach 3 environmental flow recommendations	66
	Reach 3 performance and risk assessment	66
4.5	Reach 4: Mid Billabong Creek	68
	Summary – environmental values	68
	Reach 4 environmental objectives	70
	Reach 4 environmental flow recommendations	70
	Reach 4 performance and risk assessment	72
	Reach 5: Lower Billabong Creek	76
	Summary – environmental values	76
	Reach 5 environmental objectives	77
	Reach 5 environmental flow recommendations	78
	Reach 5 performance and risk assessment	79
4.6	Reach 6: Forest Creek	83
	Summary – environmental values	83
	Reach 6 environmental objectives	86
	Reach 6 environmental flow recommendations	88
	Reach 6 performance and risk assessment	89
<b>5</b>	<b>System-wide environmental flow opportunities and priorities</b>	<b>92</b>
5.1	Environmental flow recommendations for system-scale processes	92
	Fish movement, spawning and recruitment	92
	Riparian and wetland vegetation condition and connectivity	93
	Drought refuge – weir pools	94

5.2	System-wide seasonal watering priorities	94
	Baseflow prioritisation	95
	Prioritisation of freshes	96
	Bankfull prioritisation	97
	Overbank prioritisation	97
<b>6</b>	<b>End of system flows</b>	<b>99</b>
6.1	Yanco system contribution to receiving waters	99
6.2	Potential impacts on end of system flows	100
	Approach	100
	Findings	101
<b>7</b>	<b>Next steps</b>	<b>103</b>
7.1	Flow share management	103
7.2	Physical barriers to flow provision	103
	Potential modification to existing structures and flow delivery options	104
	Risks and issues to be considered if and when upgrading weirs in the Yanco system	104
7.3	Complementary management activities	105
	Stock exclusion	105
	Willow control	105
	Large woody debris recruitment and supply	105
	Carp management	105
7.4	Monitoring	106
<b>8</b>	<b>References</b>	<b>110</b>
	<b>Attachment A Schematics of water resource operations in the Yanco Creek system</b>	<b>117</b>
	<b>Attachment B Floodplain wetland flow principles</b>	<b>122</b>
	<b>Attachment C Hydrology of the Yanco Creek system</b>	<b>126</b>

## Figures

Figure 1. <i>Project method for investigating an environmentally sustainable water regime for the Yanco Creek system</i>	4
Figure 2. <i>Yanco Creek system showing the environmental flow study reaches</i>	5
Figure 3. <i>Murrumbidgee catchment - Yanco Creek system circled in red</i>	10
Figure 4. <i>Yanco Creek system showing irrigation outfalls and major regulating structures (Source: State Water, prep by Mark Rowe 5/5/2011)</i>	11
Figure 5. <i>Modelled system wide total annual flow volume (1970-2009)</i>	17
Figure 6. <i>Modelled system wide flow duration curves</i>	19
Figure 7. <i>Modelled system wide seasonality plots</i>	20
Figure 8. <i>Comparison of present channel (blue) and paleochannel (green) planform in middle Yanco Creek (upstream of Cobb Highway)</i>	21
Figure 9. <i>Instream and emergent vegetation observed in unregulated Forest Creek at Peppinella (image taken 20 June 2012)</i>	22
Figure 10. <i>Differences in riparian vegetation in Middle Billabong Creek - Billabong Creek upstream of Jerilderie (a) and at Old Corree downstream of Jerilderie (b) (images taken 21 June 2012 (a), 22 June 2012 (b))</i>	23
Figure 11. <i>Cumbungi (Typha spp.) present in Colombo Creek at Urana-Jerilderie Rd (image taken 18 June 2012)</i>	23
Figure 12. <i>Wetlands mapped in the Yanco Creek system through two previous projects –Investigation into potential water savings from the Yanco Creek system (off-take to Yanco Bridge) wetlands (Webster 2007) (referred to as Stage 1), and the follow-on Stage 2 study (GIS data only, Webster unpublished)</i>	24
Figure 13. <i>Conceptual hydrograph for large and medium bodied fish species</i>	38
Figure 14. <i>Conceptual hydrograph for small bodied generalist fish species</i>	40
Figure 15. <i>Conceptual hydrograph for small bodied floodplain fish species</i>	41
Figure 16. <i>Survey cross section (lower Billabong Creek, chainage 623) showing feature survey to top of bank (note concentration of points in low flow channel and benches as compared to channel banks) and supplementary LiDAR survey into the floodplain.</i>	43
Figure 17. <i>Flood level indicated by tree markings (circled in red), lower Billabong Creek at Millabong (Reach 5)</i>	44
Figure 18. <i>Reach 1: Upper Yanco Creek</i>	46
Figure 19. <i>Yanco Creek looking downstream from Devlins Bridge</i>	47
Figure 20. <i>Riparian zone at Devlins Bridge, showing River Red Gum overstorey and dense and floristically diverse understorey</i>	47
Figure 21. <i>Cross section of the Upper Yanco Creek hydraulic model (XS 670) showing the environmental flow recommendations and habitat inundation</i>	51
Figure 22. <i>Reach 1 – current conditions. Number of events achieved</i>	52
Figure 23. <i>Reach 1 – current conditions. Total duration of flows above recommendation threshold</i>	53
Figure 24. <i>Reach 2: Mid Yanco Creek</i>	55
Figure 25. <i>Undercut bank (a) and range of horizontal surfaces on far bank (b).</i>	56
Figure 26. <i>Cross section of the Middle Yanco Creek hydraulic model (XS 545) showing the environmental flow recommendations and habitat inundation</i>	59
Figure 27. <i>Reach 2 – current conditions. Number of events achieved</i>	60
Figure 28. <i>Reach 2 – current conditions. Total duration of flows above recommendation threshold</i>	61
Figure 29. <i>Reach 3: Colombo Creek</i>	63
Figure 30. <i>Typical upper bank sediments at the Urana-Jerilderie Road site</i>	64
Figure 31. <i>Colombo Creek at Urana-Jerilderie Rd.</i>	64
Figure 32. <i>Reach 3 – current conditions. Number of overbank events achieved</i>	67
Figure 33. <i>Reach 3 – current conditions. Total duration of flows above recommendation threshold</i>	67
Figure 34. <i>Reach 4: Mid Billabong</i>	68
Figure 35. <i>Middle Billabong Creek at reach 4a (a) and the band of River Red Gum regeneration (b)</i>	69
Figure 36. <i>Riparian zone at Old Coree Station when stock have been removed</i>	69
Figure 37. <i>Cross section of the Middle Billabong Creek hydraulic model (XS 710) showing the environmental flow recommendations and habitat inundation</i>	71
Figure 38. <i>Reach 4 – current conditions. Number of events achieved</i>	73
Figure 39. <i>Reach 4 – current conditions. Total duration of flows above recommendation threshold</i>	74
Figure 40. <i>Reach 5: Lower Billabong Creek</i>	76
Figure 41. <i>Lower Billabong Creek at lower flow showing bed and lower bank geomorphic features (photo courtesy of Colin McCrabb)</i>	76

Figure 42. Lower Billabong Creek. Photo taken from air during field inspection	77
Figure 43. Cross section of the Lower Billabong Creek hydraulic model (XS 0) showing the environmental flow recommendations and habitat inundation (cross section facing downstream)	79
Figure 44. Reach 5 – current conditions. Number of events achieved	80
Figure 45. Reach 5 – current conditions. Total duration of flows above recommendation threshold	81
Figure 46. Reach 6: Forest Creek. Note: full extent of Forest Creek anabranch, located downstream of Wanganella, is not shown	83
Figure 47. Forest Creek downstream of Mortimers Weir. Small billabong in abandoned meander (a). Bench in main channel (b)	84
Figure 48. Wanganella Swamp. Photo taken from air during field inspection	85
Figure 49. Cross section of the unregulated Forest Creek hydraulic model (XS 2280) showing the environmental flow recommendations and habitat inundation (cross section facing downstream)	89
Figure 50. Reach 6b – current conditions. Number of events achieved	90
Figure 51. Reach 6b – current conditions. Total duration of flows above recommendation threshold	90
Figure 52. Edward River profile, Billabong Creek inflow circled in red (source: MDBA 2012, <a href="http://www.mdba.gov.au/files/Edward_LP.pdf">www.mdba.gov.au/files/Edward_LP.pdf</a> )	100
Figure 53. Augmented flow series developed through eFlow Predictor modelling. Figures show 1985-1995 (top) and 2009-2009(bottom) current, pre-development and augmented flows in Reach 5.	101
Figure 54. End of system (Reach 5) annual shortfalls	101
Figure 55. Losing, disconnected stream (water table is disconnected from the stream so that infiltration is not affected by lowering of the water table) (NSW OOW 2011)	127
Figure 56. Yanco Weir (a) and off-take channel (b)	127
Figure 57. Flow characteristics under modelled current and pre-development conditions – Reach 1, Upper Yanco. Mean daily flows (and 25 <sup>th</sup> and 75 <sup>th</sup> percentile flows under current conditions) (a); total annual daily flows (1970 – 2009) (b); and flow duration curves (c)	129
Figure 58. Flow characteristics under modelled current and pre-development conditions – Reach 2, Mid Yanco. Mean daily flows (and 25 <sup>th</sup> and 75 <sup>th</sup> percentile flows under current conditions) (a); total annual daily flows (1970 – 2009) (b); and flow duration curves (c)	130
Figure 59. Flow characteristics under modelled current and pre-development conditions – Reach 3, Colombo Creek. Mean daily flows (and 25 <sup>th</sup> and 75 <sup>th</sup> percentile flows under current conditions) (a); total annual daily flows (1970 – 2009) (b); and flow duration curves (c)	132
Figure 60. Flow characteristics under modelled current and pre-development conditions – Reach 4, Mid Billabong Creek. Mean daily flows (and 25 <sup>th</sup> and 75 <sup>th</sup> percentile flows under current conditions) (a); total annual daily flows (1970 – 2009) (b); and flow duration curves (c)	133
Figure 61. Flow characteristics under modelled current and pre-development conditions – Reach 5, Lower Billabong Creek. Mean daily flows (and 25 <sup>th</sup> and 75 <sup>th</sup> percentile flows under current conditions) (a); total annual daily flows (1970 – 2009) (b); and flow duration curves (c)	135
Figure 62. Flow characteristics under modelled current and pre-development conditions – Reach 6, Forest Creek. Mean daily flows (and 25 <sup>th</sup> and 75 <sup>th</sup> percentile flows under current conditions) (a); total annual daily flows (1970 – 2009) (b); and flow duration curves (c)	136

## Tables

Table 1. Reach selection criteria and application to the Yanco Creek system	6
Table 2. Sites inspected by the Technical Panel during field inspection 18-21 June 2012	7
Table 3. Structure of this report	8
Table 4. Summary of Commonwealth environmental water holdings as at 30 April 2012	12
Table 5. Murrumbidgee environmental water available 2012/13	12
Table 6. Summary of NSW RiverBank purchases as at 31 October 2011	13
Table 7. Fish species recorded (rec) and expected (exp) to occur in study reaches of the Yanco Creek system, based on combination of site visit and NSW Fisheries Data for the Yanco Creek system. Note: native large-bodied fish = ■ <sup>L</sup> , native medium bodied fish = ■ <sup>M</sup> , native small bodied fish = ■ <sup>S</sup> , native small bodied floodplain specialist fish = ■ <sup>F</sup>	25
Table 8. Environmental objectives for the Yanco Creek system	27
Table 9. Summary of water regime requirements of structurally dominant riparian and floodplain plant species. <i>Vallisneria</i> spp. are used as a type-species for submerged taxa.	28
Table 10. Hydrological requirements to maintain broad groups of plant types in wetlands of the Murray-Darling Basin. Sources: <sup>A</sup> Victorian Environmental Assessment Council (2006, Table 5.6) and <sup>B</sup> Rogers (2011, Table 2.5). NP = information not provided in sources	31
Table 11. Representative sites for study reaches	42
Table 12. Hydraulic parameters adopted in HEC RAS model of reaches in the Yanco System	44
Table 13. Environmental flow recommendations for Upper Yanco Creek (Reach 1)	50
Table 14. Achievement of Reach 1 baseflow recommendations under pre-development and current flow regimes	51
Table 15. Macroinvertebrate fauna found in Yanco Creek in 1998	57
Table 16. Environmental flow recommendations for Mid Yanco Creek (Reach 2)	58
Table 17. Achievement of Reach 2 baseflow recommendations under pre-development and current flow regimes	59
Table 18. Environmental flow recommendations for Colombo Creek (Reach 3)	66
Table 19. Achievement of Reach 3 baseflow recommendations under pre-development and current flow regimes	66
Table 20. Environmental flow recommendations for Mid Billabong Creek (Reach 4a)	71
Table 21. Environmental flow recommendations for Billabong Creek (Reach 4b)	72
Table 22. Achievement of Reach 4 baseflow recommendations under pre-development and current flow regimes	72
Table 23. Environmental flow recommendations for Lower Billabong Creek (Reach 5)	78
Table 24. Achievement of Reach 5 baseflow recommendations under pre-development and current flow regimes	79
Table 25. Timing, duration of flooding, key habitats and minimum depths required to ensure successful habitation and/or breeding of indicator species in Wanganella Swamp (Webster <i>et al</i> 2012)	87
Table 26. Environmental flow recommendations for unregulated Forest Creek (Reach 6b)	88
Table 27. Achievement of Reach 6b baseflow recommendations under pre-development and current flow regimes	89
Table 28. Flow recommendations for riparian and wetland vegetation in the Yanco Creek system	93
Table 29. Management objectives for environmental water use under different resource availability scenarios (adapted from CEWO 2012)	94
Table 30. Priorities for baseflow component provision based on different water availability scenarios	95
Table 31. Priorities for fresh component provision based on different climatic scenarios	96
Table 32. Priorities for bankfull component provision based on different climatic scenarios	97
Table 33. Priorities for overbank component provision based on different climatic scenarios	98
Table 34. Annual water shortfall volume for Reach 5 (Lower Billabong Creek) to achieve full environmental flow recommendation compliance	102
Table 35. Recommended monitoring to assess condition and monitor the impact of environmental water management in the Yanco Creek system	107



## Glossary

Bankfull flow	Completely fill the channel, with little flow spilling onto the floodplain.
Cease to flow	No discernible flow in the river, or no measurable flow recorded at a gauge.
Current flow conditions	Long-term flow series simulating behaviour of the system under the current Murrumbidgee Regulated River Water Sharing Plan. Allocated diversions information is based on data collected from 1990s-2000s and reflects the level of irrigation development around the time the Water Sharing Plan was implemented in 2004
High flow	A continual increase in the seasonal baseflow. A high flow remains within the channel and connects most habitats within the channel.
High flow freshes	Small and short duration peak flow events that exceed the baseflow (high flow) and last for at least several days. Usually in winter and spring in Victoria.
Hydraulic roughness	Refer to Manning's 'n'
Independence of flow events	Where a flow series is being assessed for the recurrence of a particular flow event that exceeds a threshold magnitude, an independence criteria is applied (in this case 14 days). If the flow drops below the threshold magnitude for less than 14 days, the two peaks above the threshold are not considered to be 'independent' and will only be counted as a single event.
Low flow	Flow that generally provides a continuous flow through the channel.
Low flow freshes	Small and short duration peak flow events that exceed the baseflow (low flow) and last for at least several days. Usually in summer and autumn in Victoria.
Manning's 'n'	The Manning coefficient of hydraulic roughness, often denoted as n, is an empirically derived coefficient, which is dependent on many factors, including river-bottom roughness and sinuosity. Values typically range between 0.02 for smooth and straight rivers, to 0.075 for sinuous rivers and creeks with excess debris on the river bottom or river banks.
Overbank flow	Flows greater than bankfull which result in surface flow on the floodplain habitats.
Pre-development flow conditions	Long-term flow series simulating the best estimate of natural flows in the Yanco Creek system, utilising historical inflow series for tributaries and dam locations, no structures, irrigation or other demands, and river loss functions as per the Water Sharing Plan model

## Abbreviations

CCD	Coleambally Catchment Drain
CEWH	Commonwealth Environmental Water Holder
CEWO	Commonwealth Environmental Water Office
CMA	Catchment Management Authority
CRC	Cooperative Research Centre
DC800	Drainage Canal 800
DNRE	Victorian Department of Natural Resources and Environment (now Department of Sustainability and Environment)
DPI	NSW Department of Primary Industries
FCWG	Forest Creek Working Group
IQQM	Integrated water Quantity and Quality Model
MDBA	Murray Darling Basin Authority
NSW	New South Wales
OEH	NSW Office of Environment and Heritage
OoW	NSW Office of Water
RERP	Rivers Environmental Restoration Program
SRA	Sustainable Rivers Audit
WSP	Water Sharing Plan
XS	Cross section
YACTAC	Yanco Creek and Tributaries Advisory Council

# 1 Introduction

## 1.1 Background to the study

This environmental flows study was initiated by the Yanco Creek and Tributaries Advisory Council (YACTAC) to address the lack of recognition of the Yanco Creek System in the Water Sharing Plan for the Murrumbidgee Regulated River Water Source 2003. There was also concern about water savings projects removing water from the system without a good understanding of the potential environmental impacts.

Prior to 2006 the Murrumbidgee Water Sharing Plan included a requirement for a 100 ML/d replenishment flow over Warriston Weir to supply stock and domestic water to landholders along the Forest Creek and Forest Creek Anabranch. Water for Rivers successfully negotiated two projects (Forest Creek Stages 1 and 2) which included alternative stock and domestic supplies to landholders. 34.7GL of Murrumbidgee high security water was converted to environmental water with zero regulated flows the new target over Warriston Weir.

In 2007, Water for Rivers agreed to fund this Environmental Flows Study as well as a report on Wanganella Swamp. The Wanganella Swamp Management Plan was completed in 2011. In 2010, Water for Rivers signed an agreement with State Water and NSW Office of Water for the finalisation of water savings projects in the Murrumbidgee. State Water assumed responsibility for the implementation of these projects, one being this Environmental Flows Study.

This environmental flows study will be useful for inclusion in the next round of water sharing plan development, for sourcing and targeting delivery of environmental flows and as a platform for further environmental works and measures in the Yanco system.

### 1.1.1 Scope

The Yanco Creek system supplies water to a vast area of the Riverine Plains of New South Wales for agricultural production and also water supply for townships of Morundah, Urana, Oaklands, Jerilderie, Conargo and Wanganella. Along the system there are a number of environmental assets including significant wetland areas that have been impacted by historic water management practices. The community along the creek system is highly committed to improving the ecological health of all the system and has initiated and/or supported several studies and environmental restoration programs, particularly for riparian habitat.

Water management for the entire system is governed by the Water Sharing Plan for the Murrumbidgee Regulated River Water Source 2003. However the environmental flow provisions of the Water Sharing Plan do not target ecological outcomes for the Yanco Creek System.

The aim of this environmental flows study is to derive scientifically based recommendations to identify the benefits for the use of environmental water in the Yanco Creek system from the available sources in the regulated Murrumbidgee or NSW Murray River systems. The scope of the environmental flows study includes:

- Assessment and integration of a substantial amount of existing ecological and hydrological data and reports for each of the Creeks and individual localities.
- Development of environmental flow requirements for a range of ecological attributes of the system as a whole and for each Creek.
- Identification of the relative contribution the system can make to specified environmental flow requirements in the Edward/Murray River.
- Identification of environmental flow requirements and provision of practical and realistic environmental flow recommendations
- Identification of risks or benefits to environmental outcomes on the creeks which may arise due to water efficiency activities and changes to operating regimes.

The scope of this study does not include:

- Development of flow sharing rules for water resource plans
- Identification of water requirements for social and/or economic benefit
- Development of individual wetland watering plans for wetland assets present in the system

Alluvium was engaged by State Water to undertake the environmental flows study. This *Final Report* describes the environmental values and threats in the Yanco Creek system, environmental objectives for flow dependent environmental values, reach by reach environmental flow requirements to meet the objectives, and an assessment of the performance and risk associated with the current water management regime. This report builds on information presented in the *Site Paper* and the *Issues Paper*.

## 1.2 Method

There are many methods for determining environmental water requirements for flow dependent ecological values (ie. the FLOWS method used throughout Victoria (DNRE 2002), the Tasmanian Environmental Flows Framework, the 80:20 rule applied in the Northern Territory, or the eco-hydrologic approaches used in Queensland). The New South Wales State Government and water managers do not use a standard method for the determination of environmental flows. Therefore, we have developed a method that draws on the elements of the existing flow determination approaches that can be completed within the scope of this project (tasks outlined in Figure 1).

The environmental flows study is aimed at identifying the key environmental values and functions of the Yanco Creek system, and providing recommendations for their specific ecological watering requirements. Environmental values are identified through a desktop exercise and field assessment with a scientific technical panel. The values and their interaction with the natural hydrology and the current modified hydrology form part of this study. The negative and positive impacts of the current hydrology are key project outputs.

This process provides an understanding of how to protect the identified values and determine the watering regime appropriate to achieve the environmental objectives for the Yanco Creek system. This water regime is described in terms of flow components that are important to the values.

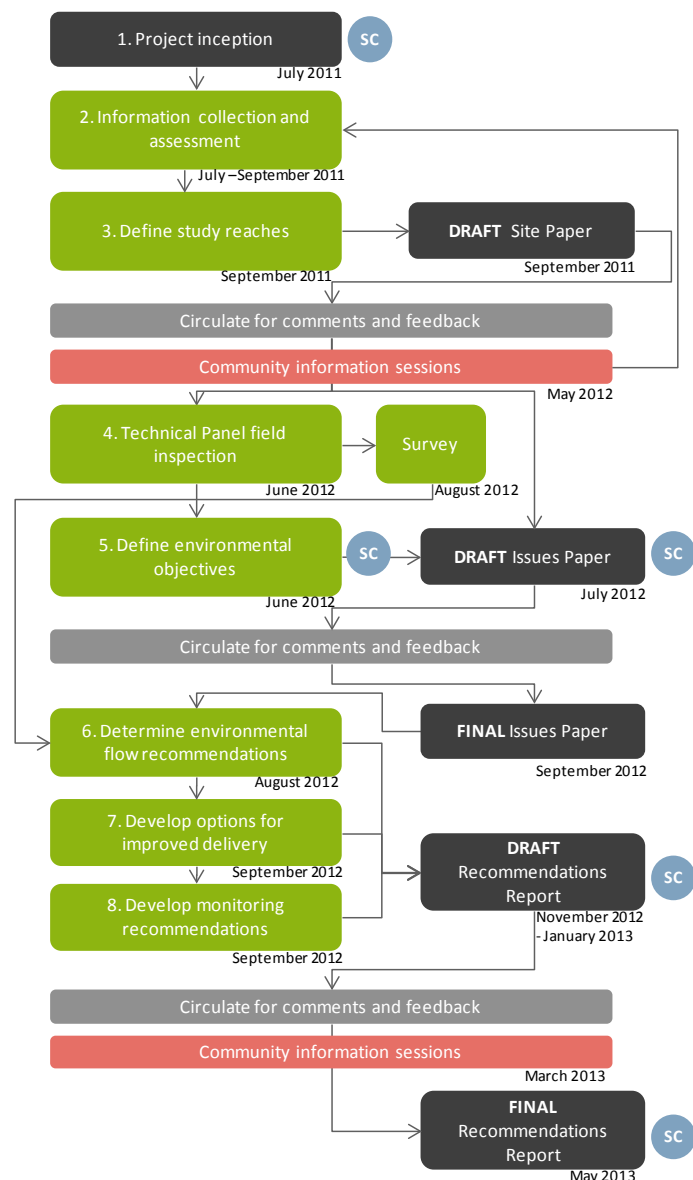

**Figure 1.** Project method for investigating an environmentally sustainable water regime for the Yanco Creek system

The study was undertaken through the tasks outlined in Figure 1. The Draft Site Paper was circulated in September 2011 and comments were received from numerous parties which have been addressed in the Issues Paper (finalised September 2012). This report forms the final deliverable of the study.

### 1.3 Study area

The study area for this assessment is the Yanco Creek System which is an effluent of the Murrumbidgee River downstream of Narrandera which flows south-west, discharging into the Edward River (part of the Murray River basin) at Moulamein. The Yanco Creek system includes the floodplains of the Yanco Creek, the regulated portion of Billabong Creek, Colombo Creek, the regulated and unregulated portions of Forest Creek, and the significant environmental values serviced by these. The Forest Creek anabranch was not specifically included in the study area<sup>1</sup>.

#### Study reaches

To determine environmental flow requirements for the Yanco Creek system, the study area is divided into reaches that are relatively homogeneous in terms of the following features:

- Location of major tributaries
- Channel morphology and structure
- Floodplain morphology and structure
- Presence of key habitats of value
- System operation
- Flora and fauna structure and value

The Technical Panel has recommended that the Yanco Creek system be assessed as six reaches for the purpose of the environmental flow determination. These reaches are (Figure 2):

1	Upper Yanco Creek	from Yanco off-take to Sheepwash weir pool (Colombo Creek)
2	Mid Yanco Creek	from Tarabah Weir to confluence with Billabong Creek
3	Colombo Creek	from Sheepwash weir pool to Cocketgedong weir
4	Mid Billabong Creek	Cocketgedong weir to Yanco Creek confluence. Sub-reach 4a upstream of Jerilderie, sub-reach 4b downstream of Jerilderie
5	Lower Billabong Creek	downstream of Yanco confluence to Edward River
6	Forest Creek	regulated (sub-reach 6a) and unregulated (sub-reach 6b) sections

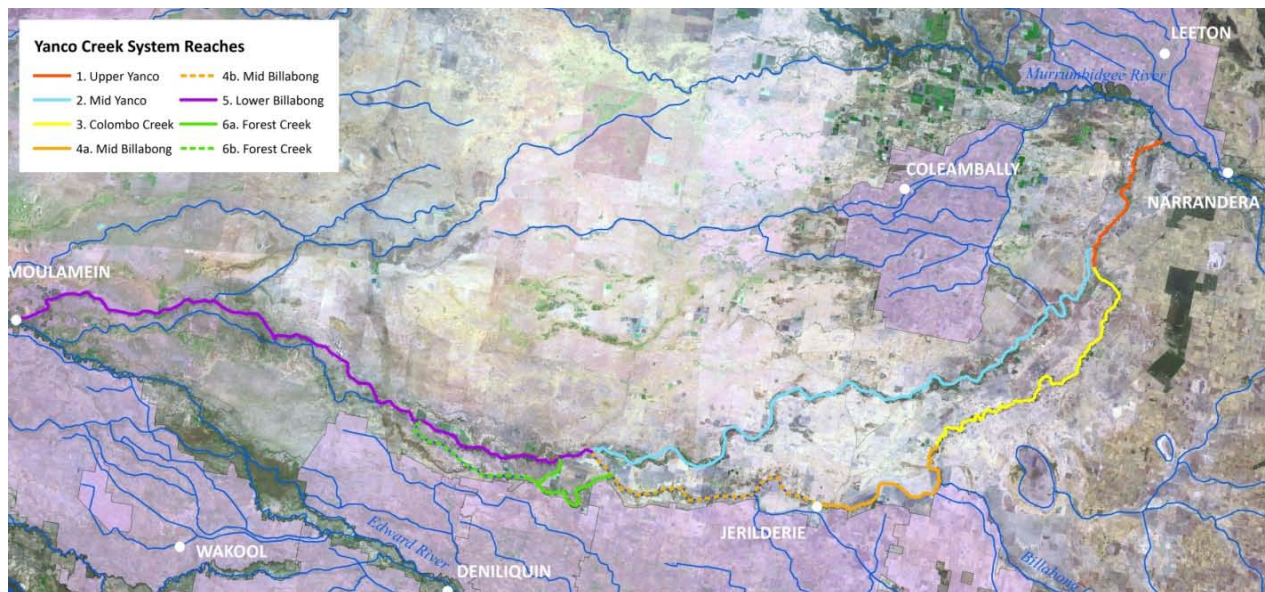

**Figure 2.** Yanco Creek system showing the environmental flow study reaches

<sup>1</sup> Sufficient data for the Forest Creek anabranch was not available to enable inclusion of this section of the system in the study. Modelled daily flow data and ecological surveys are required to undertake such assessment.

The rationale for the recommended reaches is summarised in Table 1.

**Table 1. Reach selection criteria and application to the Yanco Creek system**

Criteria	Summary of characteristics	Reach
Location of major tributaries / distributaries	Washpen Creek – right bank distributary, leaves Yanco Creek near Morundah and re-enters downstream of Tarabah Weir	1
	Coleambally Catchment Drain (CCD) – right bank tributary drain from Coleambally Irrigation Area, enters Yanco Creek	2
	Drainage Canal 800 (DC800)– right bank tributary drain from Coleambally Irrigation Area, enters Yanco Creek	2
	Unregulated Billabong Creek – left bank tributary, enters Billabong Creek at Colombo Creek confluence	4
	Forest Creek – left bank distributary, leaves Billabong Creek at Forest Creek off-take and re-enters Billabong Creek through numerous creeks including Piccaninny Creek, Eight Mile Creek and unregulated Forest Creek	6
	Forest creek anabranch <sup>2</sup> – left bank distributary, leaves Billabong and Forest creeks downstream of Wanganella Swamp, enters the Edward River upstream of Moulamein	-
Channel morphology and structure	Simple cross section morphology with well connected channel and floodplain. Sandy-silt dominated banks. In channel hydraulic diversity evident with variable loading of large wood throughout.	1, 2
	Homogeneous cross section morphology with broad, shallow banks. Little evidence of in channel diversity.	3
	Broad asymmetric cross section morphology. Alternating steep, high banks with opposite broad, shallow bank.	4
	Deep and steep banks. Frequently inundated narrow floodplain set below broader (infrequently inundated) floodplain. In channel hydraulic diversity evident with variable loading of large wood throughout and deep pools.	5
	Simple cross section morphology with broad, shallow banks.	6
Floodplain morphology and structure	Broad floodplain with numerous relic flow paths now forming scattered floodplain depressions within riparian corridor. Highly sinuous main channel with connection to significant wetland complexes.	1, 2
	Narrow floodplain with generally similar plan form to (low sinuosity) main channel	3, 4, 6
	Moderate width floodplain with some relic flow paths forming scattered floodplain depressions	5
Presence of key habitats of value	Instream hydraulic diversity with variable large wood loading throughout. Connectivity with scattered floodplain depressions, wetland complexes and longitudinally (to Murrumbidgee River)	1, 2
	Persistent weir pools throughout with brief sections of flow downstream of weirs. Drought refugia with limited longitudinal connectivity (presence of weirs).	3, 4b, 5, 6a
	In channel diversity including deep pools, benches and variable loading of large wood.	5
	Connection with Wanganella Swamp	6
System operation	Bulk of water supplied to the Yanco System via off take (volume entering Yanco Creek is well controlled up to 10,000 ML/d in the Murrumbidgee River).	1
	Drainage and regulated flows enter the system via the CCD, DC800, and WWC channels	2, 5
	Flow split between mid Yanco and Colombo Creeks controlled by Tarabah Weir	2, 3
	Fixed crest weirs (no control of flow magnitude) influence system operation throughout	3, 4b, 5, 6a

<sup>2</sup> The Forest Creek anabranch was not considered part of the study area

Criteria	Summary of characteristics	Reach
	Colombo Creek joins unregulated Billabong Creek (and continues as Billabong Creek)	4
	Hartwood Weir allows sharing of flows between Billabong Creek and Forest Creek (and downstream Eight Mile Creek/Wanganella Wetland)	5, 6
	No flow beyond regulated Forest Creek (Warriston Weir)	6
Flora and fauna structure and value	Variable width frequently inundated community of River Red Gum dominated overstorey with healthy understorey of diverse rushes, reed and sedges. Black Box present beyond frequently inundated zone	1, 2
	Thick and narrow riparian stand dominated by River Red Gum with <i>Typha</i> fringe	3
	Degraded homogeneous corridor with poor longitudinal connectivity	4a
	Wide riparian corridor with good longitudinal connectivity	4b
	Narrow River Red Gum dominated riparian corridor with good longitudinal connectivity	5
	Wide River Red Gum dominated riparian corridor	6a
	Black Box dominated narrow riparian stand	6b

### Environmental flows study sites

In the development of environmental flow recommendations, a number of sites were inspected by the Technical Panel during a four day field inspection (18-21 June 2012). These sites (Table 2) are described in further detail in the Issues Paper (Alluvium 2012).

**Table 2. Sites inspected by the Technical Panel during field inspection 18-21 June 2012**

Reach	Description	Date inspected
1 Upper Yanco Creek	Yanco Creek at Yanco weir	19 June 2012
	Dry Lake, Mollys Lagoon, Back Creek	19 June 2012
	Yanco Creek at Devlins Bridge	19 June 2012
	Yanco Creek at Morundah	18 June 2012
2 Mid Yanco Creek	Yanco Creek at Tarabah Weir	19 June 2012
	Yanco Creek at TSR	19 June 2012
	Yanco Creek at Silver Pines	19 June 2012
	Yanco Creek at Yanco Bridge	21 June 2012
3 Colombo Creek	Colombo Creek at Urana Jerilderie Rd	18 June 2012
	Colombo Creek – Chesneys Weir	18 June 2012
	Colombo Creek ski club, off Coonong Rd	18 June 2012
	Colombo Creek at TSR – Sheepwash weir pool	18 June 2012
4 Mid Billabong Creek	Billabong Creek at Jerilderie	21 June 2012
	Billabong Creek at Brick Kiln	21 June 2012
	Billabong Creek at Old Coree	21 June 2012
5 Lower Billabong Creek	Billabong Creek at Four Mile Weir	20 June 2012
	Billabong Creek at Wanganella	20 June 2012
	Billabong Creek at Millabong	20 June 2012
6 Forest Creek	Forest Creek off-take	20 June 2012
	Warriston weir	20 June 2012
	Forest Creek at Peppinella	20 June 2012
	Eight Mile Creek	20 June 2012
	Wanganella swamp	20 June 2012
	Forest Creek anabranch	20 June 2012

Due to the limited detailed scientific studies or information available, the Technical Panel has relied on the visits to a number of sites in the reach and the aerial survey undertaken during the field inspection of June 2012; and experience in similar river systems in south eastern Australia, especially in the Murray-Darling Basin. High flows at the time of field visits limited the Panel's ability to observe bed and lower bank features and characteristics at a number of sites. Where possible the physical form was inferred from hydraulic and physical forms visible above the water surface and verified following field cross section survey.

## 1.4 The Final Report (this report)

The approach to determining the environmental flow requirements for the Yanco Creek system is focussed on taking the concepts and theory of environmental flows and translating those through a transparent, robust scientific process into flow magnitudes, frequency, duration and timing that can be used to develop operating regimes for regulating structures.

The structure of this report is shown below, indicating where each of the study terms of reference has been addressed.

**Table 3. Structure of this report**

Section	Description of content	Relevant study term of reference addressed
<b>1</b> Introduction	Outline of the background and scope of the study.	-
<b>2</b> Yanco Creek System	Summary of the current and potential condition of water dependent environmental values of the catchment, and the current threats to the water dependent environmental values within the catchment, specifically resulting from any system operation, water extraction and harvesting Summary description of the system characteristics including hydrology, geomorphology, vegetation, wetlands, fish and macroinvertebrates	Assessment and integration of a substantial amount of existing ecological and hydrological data and reports for each of the Creeks and individual localities.
<b>3</b> Environmental objectives	Environmental objectives that are described in terms of the ecological or geomorphic functions of the stream flows in the catchment	Development of environmental flow requirements for a range of ecological attributes of the system as a whole and for each Creek.
<b>4</b> Environmental flow recommendations	Approach applied to determine environmental flow recommendations Environmental flow recommendations for each study reach Performance assessment of the environmental flow recommendations against the current flow regime Risk assessment outlining the potential risks associated with the current and any potential future water management regimes.	Development of environmental flow requirements for a range of ecological attributes of the system as a whole and for each Creek. Identification of environmental flow requirements and provision of practical and realistic environmental flow recommendations Identification of risks or benefits to environmental outcomes on the creeks which may arise due to water efficiency activities and changes to operating regimes
<b>5</b> System-wide environmental flow opportunities and provision	Description of system scale environmental flow recommendations Discussion of seasonal priorities for environmental flow provision	Identification of environmental flow requirements and provision of practical and realistic environmental flow recommendations.
<b>6</b> End of system flows	Identification of potential volumes required to achieve environmental flow recommendations in the Yanco system, and the potential flow reduction to the Edward Wakool system.	Identification of the relative contribution the system can make to specified environmental flow requirements in the Edward/Murray River. Identification of risks or benefits to environmental outcomes on the creeks which

Section	Description of content	Relevant study term of reference addressed
		may arise due to water efficiency activities and changes to operating regimes
<b>7</b> Next steps	Recommendations relating to the development of operational arrangements for implementation of the environmental flow recommendations. Includes discussion of barriers for removal, monitoring requirements and complementary catchment management actions.	
<b>8</b> References	Full reference list	Assessment and integration of a substantial amount of existing ecological and hydrological data and reports for each of the Creeks and individual localities.
<b>Attachment A</b> Water resource schematics	Diagrams outlining system operation in each reach	
<b>Attachment B</b> Floodplain wetland flow principles	Detailed information regarding watering principles for floodplain wetlands	
<b>Attachment C</b> Hydrology	Reach by reach assessment of pre-development and current hydrology	





## 2 Yanco Creek system

This section provides a summary of the hydrological and ecological data<sup>3</sup> available for the Yanco Creek system relevant to this study. System characteristics described in this section have been summarised from detailed assessments reported in the Site Paper and Issues Paper (Alluvium 2012). This section contains a summary of:

- water resource development and management in the Yanco Creek system (including the changes from pre-development to current operating conditions)
- hydrological and ecological characteristics of the system

### 2.1 Overview

The Yanco Creek system is situated in the Riverine plains of southern New South Wales (Figure 3). The system receives most inflow from the Murrumbidgee River, and also catchment inflows from the unregulated Billabong Creek (upstream of Colombo Creek confluence). The system discharges to the Edward River, an effluent of the Murray River, near Moulamein.

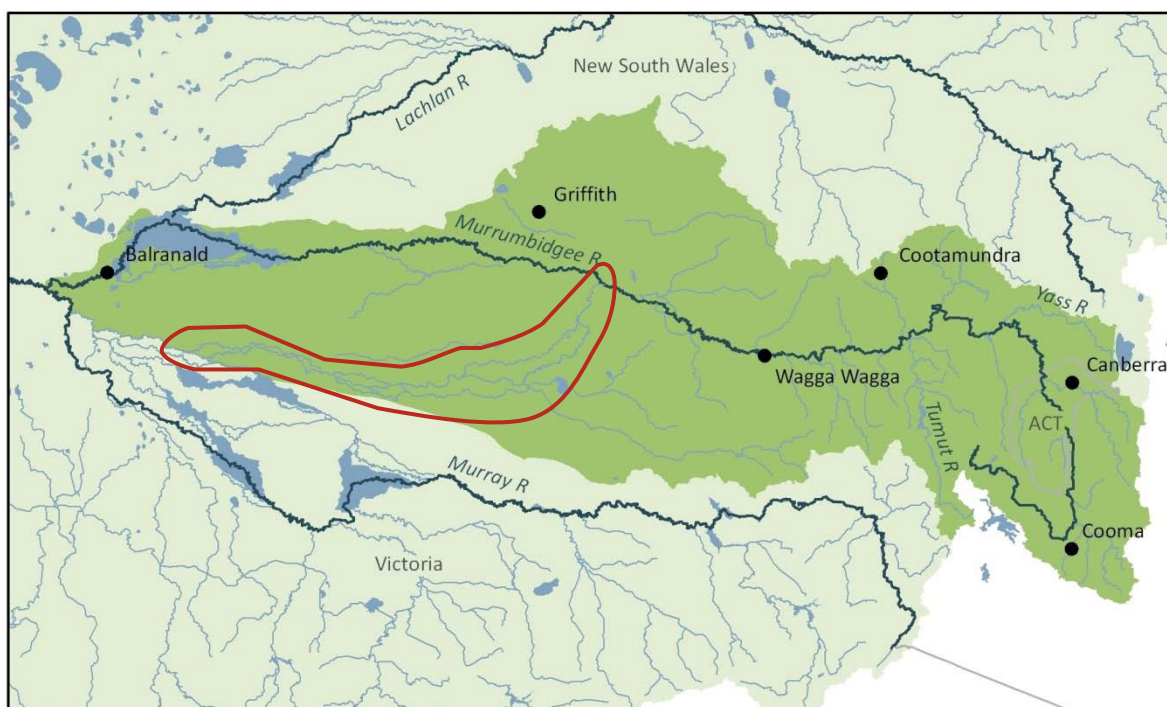

**Figure 3.** Murrumbidgee catchment - Yanco Creek system circled in red

The Yanco Creek commences as an off-take from the Murrumbidgee River at Yanco Weir downstream of Narrandera. It travels in a south west direction before diverging into two separate channels upstream of Morundah. The northern arm retains the name Yanco Creek, whilst the southern arm is initially called Colombo Creek, and then Billabong Creek after the junction with upper (or unregulated) Billabong Creek. The Yanco Creek joins Billabong Creek at Conargo, and the downstream channel is named Billabong Creek (until it's confluence with the Edward River). The Forest Creek system is an anabranch of Billabong Creek, which diverges from the creek upstream of the confluence with Yanco Creek and reconnects shortly before Wanganella. Flows are controlled at the Forest Creek off-take and it is a regulated stream only as far as Warriston Weir. Just downstream of Wanganella, Forest Creek Anabranch leaves the Billabong Creek and eventually rejoins the Billabong just upstream of Moulamein, after which it discharges into the Edward River. The Eight Mile Creek connects the Forest Creek to Forest Creek Anabranch via the Wanganella Swamp.

<sup>3</sup> Data available up to August 2012 (timing of the Technical Panel workshop) has been included in this study. Additional information has and will become available over time and should be considered in any update to the environmental flow recommendations in the future.

The bulk of water supplied to Yanco Creek System from the Murrumbidgee River is via the Yanco off take. Additional flows from the Murrumbidgee enter the system from drainage channels out of the Coleambally Irrigation Area (the Coleambally Catchment Drain, Drainage Canal 800, West Coleambally Channel). Water from the Murray system enters the Billabong and Forest Creeks through numerous Murray Irrigation Area escapes and drains, the main one being Finley Escape.

## 2.2 Water resource development and management

Irrigation works in the last century have significantly altered the Yanco Creek system flow regime. Prior to irrigation development the system would have flowed only when flooding was occurring in the Murrumbidgee River (flows >40GL at the Yanco off-take) and/or when there was substantial runoff and flows in the upper catchment of Billabong Creek (Molino Stewart 1999). Demand for water in the area led to the construction of a significant number of structures, both publicly and privately owned, that impact on flows along the system. These include the off-take from the Murrumbidgee River, and weirs, regulators, block dams and by-wash dams throughout the creek system (Figure 4).

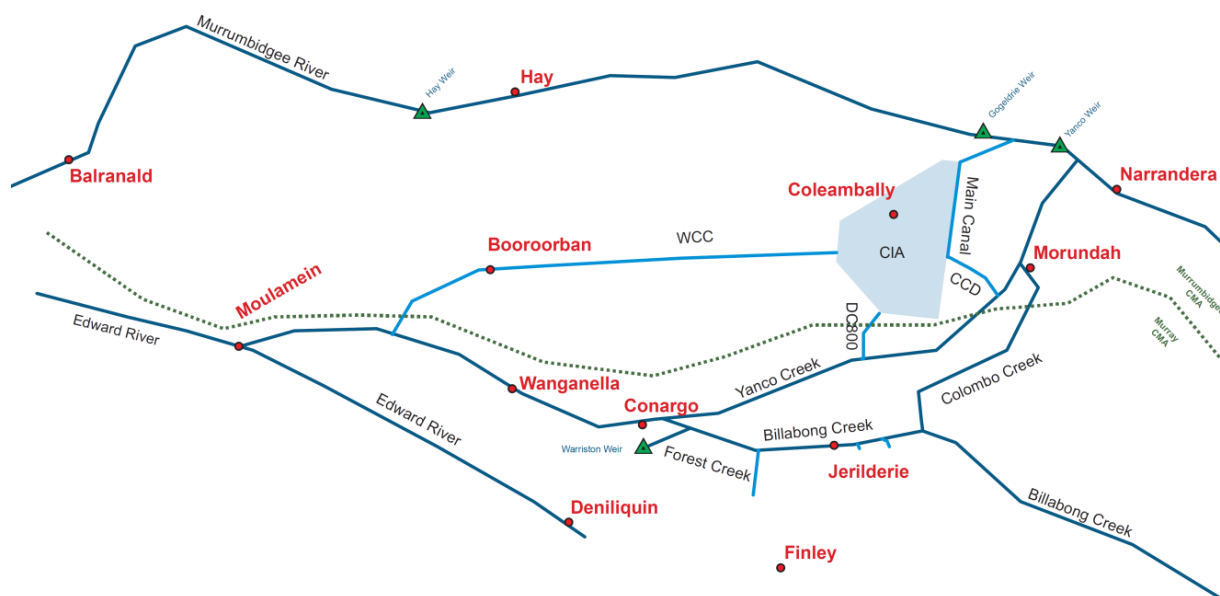

**Figure 4.** Yanco Creek system showing irrigation outfalls and major regulating structures (Source: State Water, prep by Mark Rowe 5/5/2011)

Downstream of Morundah, Yanco Creek has a much greater flow capacity than Colombo Creek and carries the major portion of the unregulated flows that generally occur in winter-spring, whereas Colombo Creek carries the major portion of regulated flows in summer-autumn (Molino Stewart 1999). Both Yanco Creek and Billabong Creek also receive inflows from drains and/or tributary streams. Yanco Creek receives flows from the Coleambally Catchment Drain (CCD) and drain DC 800, both of which carry drainage flows and regulated releases from the Coleambally Irrigation Area. The Billabong Creek receives inflows from a number of creeks and drains, namely the upper (or unregulated) Billabong Creek which has a catchment that extends 160km to the east of Colombo Creek (Molino Stewart 1999). Murray Irrigation Limited (MIL) delivers drainage water and some regulated flows to the Billabong and Forest Creeks. The main MIL channel used for regulated flows is Finley Escape.

Forest Creek is an anabranch of Billabong Creek which has a limited capacity and only receives a fraction of the flood flows of Billabong Creek. Hartwood Weir, downstream of the junction of Billabong Creek and Forest Creek, allows sharing of the regulated flows between the two creeks. Forest Creek flows are confined to a pre-development channel but Eight Mile Creek splits off the Forest Creek in Peppinella and it spreads out in the vicinity of Wanganella Swamp before being confined to a channel again downstream of McCrabbs Regulator. Flows from Forest Creek, Eight Mile Creek and Forest Creek Anabranch tend to return to Billabong Creek via

small interconnecting creeks and breakaways due to a difference in height between the two creeks. Many block banks are constructed along these creeks to prevent this return of flow.

It takes approximately 5-6 weeks for regulated flows to pass from the Murrumbidgee irrigation dams through the Yanco Creek system to Moulamein (Beal et al. 2004).

#### **Available environmental water**

The Commonwealth Environmental Water Holder (CEWH) and New South Wales both hold entitlements to water for environmental use that can be delivered to the Yanco Creek System to achieve environmental objectives.

#### **Commonwealth environmental water**

The Commonwealth has been acquiring water entitlements in the Murray Darling Basin through direct buy-backs from irrigators and savings from infrastructure upgrades with the objective of returning more water to the environment. As at 30 April 2012, the Commonwealth environmental water holdings in the Murrumbidgee and NSW Murray systems, which potentially could be used to achieve environmental objectives in the Yanco Creek system, are greater than 150 GL (Murrumbidgee) and 200 GL (NSW Murray) of general security entitlement. A breakdown of Commonwealth holdings is shown in Table 4.<sup>4</sup>

**Table 4. Summary of Commonwealth environmental water holdings as at 30 April 2012**

<b>Southern Connected Basin Valley</b>	<b>Security</b>	<b>Entitlement volume (GL)</b>
Murrumbidgee	High	0.4
	General	153
	Conveyance	1.6
	Supplementary	20.8
NSW Murray	High	2.6
	General	232

Note: The volumes in this table include only entitlements which have been formally transferred to the Commonwealth (i.e. registered with the relevant NSW authority) at 30 April 2012. Registration can occur a number of months after the exchange of contract.

Commonwealth environmental water is required to be managed for the purpose of protecting or restoring the environmental assets of the Murray-Darling Basin. It must be managed in accordance with relevant environmental water plans (including the Environmental Watering Plan under the Basin Plan), any operating rules made under the *Water Act 2007*, and any environmental watering schedules to which the CEWH is party.

#### **NSW environmental water**

New South Wales holds water entitlements to water for the environment in the Murrumbidgee and Murray basins which can be delivered to the Yanco Creek System to achieve environmental objectives (Table 5). The bulk of NSW owned water was purchased under the Living Murray Initiative. This program saw the purchase of 115 GL of entitlements across the Murray, Murrumbidgee and Darling Rivers. The NSW Living Murray entitlement is currently managed by the Murray Darling Basin Authority (MDBA).

**Table 5. Murrumbidgee environmental water available 2012/13**

<b>Account</b>	<b>Maximum GL</b>	<b>GL available at 1/7/12 (64%AWD)</b>
<b>OEH Adaptive Environmental Water</b>		
General Security	27.7	22.2 (includes carryover)
Supplementary	5.7	Available at 10/7/12
Unregulated	5.9	N/A
<b>Environmental Water Allowance (EWA)</b>		
EWA1		56*

<sup>4</sup> (<http://www.environment.gov.au/ewater/about/holdings.html>)

Account	Maximum GL	GL available at 1/7/12 (64%AWD)
EWA2		36
EWA3		40*
<b>Commonwealth Environmental Water</b>		
High security	0.5	0.5
General security	157.7	100.9
Supplementary	3.2	Available at 10/7/12
Unregulated	20.8	

The NSW RiverBank is a separate purchasing program, coordinated by the Office of Environment and Heritage. Under this program, NSW has purchased more than 20 GL of general entitlement. Table 6 shows the breakdown of entitlements purchased in the Murrumbidgee River under the RiverBank program. Note that no entitlements were purchased in the NSW Murray basin, and the program was scheduled for completion by December 2011.<sup>5</sup>

**Table 6. Summary of NSW RiverBank purchases as at 31 October 2011**

Basin	Security	Entitlement volume (GL)
Murrumbidgee	General	23.9
	Supplementary	5.7
	Unregulated	6.2

## 2.3 Water resource plans

### Murrumbidgee Water Sharing Plan

The Murrumbidgee Regulated River Water Sharing Plan 2003 (Murrumbidgee WSP) is the statutory water management plan (under the *Water Management Act 2000*) encompassing the Yanco Creek system. The plan is based on recommendations from the former Murrumbidgee River Management Committee (which included representatives from the irrigation industry, indigenous communities, the CMAs, state and local government agencies). It commenced on July 1, 2004, and was suspended from November 2006 to September 2011 due to severe drought conditions.

The Murrumbidgee WSP aims to 'provide equitable sharing of limited water resources to sustain a healthy and productive river and the welfare and well-being of Murrumbidgee regional communities' (DIPNR 2004). The Plan specifies the following environmental water rules:

1. Reserve all water above the extraction limit for the environment
2. Protect low flows in the upper reaches (of the Murrumbidgee River)
3. Provide winter flow variability
4. Establish environmental water allowances
5. Protect end of system flows (on the Murrumbidgee River)

The environmental flow provisions in the Murrumbidgee WSP do not specifically target ecological outcomes for the Yanco Creek system<sup>6</sup>.

<sup>5</sup> (<http://www.environment.nsw.gov.au/environmentalwater/waterpurchase.htm>)

<sup>6</sup> Note that a proposed amendment to the water sharing plan is currently under consideration. This amendment does not propose any change to the environmental water rules or affect the Yanco Creek system.

### Annual Environmental Watering Plans

Adaptive environmental watering plans are statutory instruments prepared by the Office of Environment and Heritage in consultation with Environmental Watering Advisory Groups and approved by the NSW Office of Water. Annual plans completed for the Murrumbidgee and NSW Murray identify the primary objectives for environmental water in the catchments, and outline how the available and potential environmental water will be used in each catchment during the year.

The *Environmental Watering Plan for the Murrumbidgee Valley 2011/12* guides the prioritisation of sites for environmental watering in the Murrumbidgee Valley (from Commonwealth and State allocations) during the 2011/12 season. Ten primary objectives have been identified for the use of environmental water in 2011/12 and are shown below: (Note these objectives are unchanged from the 2010/11 objectives)

1. To improve and/or maintain the condition of a diversity of wetland types within the Murrumbidgee Valley
2. To prevent the further decline in stressed wetland vegetation communities, in particular River Red Gum, Black Box and Lignum communities
3. To assist in the best management of RAMSAR wetlands and “native fish in wetlands” demonstration sites
4. To increase and/or maintain the abundance and diversity of wetlands and riparian aquatic vegetation
5. To reinstate a wetting/drying cycle for natural ephemeral floodplain wetlands that have been negatively impacted by river regulation and/or severe drought conditions
6. To provide habitat for wetland-dependent fauna including endangered species such as the Southern Bell Frog and Fishing Bat
7. To trigger and/or maintain colonial waterbird breeding events primarily in the Lowbidgee wetlands
8. To complement naturally occurring higher river flows (or if necessary create high flows) that provide a benefit to wetland/floodplain dependent fauna and flora communities by increasing duration and/or extent of inundation
9. To minimise the adverse impacts that altered flow rates may have on instream fauna, in particular native fish populations
10. To assist in furthering the understanding of biological processes and functions within wetland/riverine habitats that will inform future management of environmental water allocations

Based on these objectives, the following sites in the Yanco Creek system have been identified for potential watering during the 2011/12 season:

- Yanco and Colombo Creeks, to introduce flow variability that has been removed and attenuated by flow regulation, to benefit populations of threatened fish and endangered aquatic ecological communities
- Wanganella Swamp

The *Murray Valley Annual Environmental Watering Plan for 2012/13* outlines the proposed use of environmental water (from Commonwealth and state allocations) in the NSW Murray Valley for the 2012/13 season. The plan sets eight primary objectives (identical to those in the *Environmental Watering Plan for the Murrumbidgee Valley 2012/13*) for environmental watering, and lists Wanganella Swamp as an asset to receive water under a median/wet scenario if a large breeding event is triggered and needs to be maintained.

Based on the primary objectives, the Wanganella Swamp on the Forest Creek floodplain has been identified as a potential site for receiving environmental water during 2012/13. Over 12 GL of environmental water was used to inundate the swamp during 2010/11 to sustain a significant bird breeding event and attracting up to 13,000 pairs of Straw-necked Ibis, as well as national and internationally listed species of waterbirds. If another large bird breeding event is triggered naturally in 2012/13 and there are insufficient inflows to support

the event to its end, the environmental watering plan recommends the provision of environmental water to sustain it.

In addition to the State plans, the Commonwealth Environmental Water Office publishes *Annual Water Use Options* for the Murrumbidgee Catchment. The annual options document sets out the proposed approach for the use of Commonwealth environmental water in the catchment based on a range of possible river conditions. The Commonwealth's environmental watering program objectives are dependent upon the prevailing climatic conditions during the period for which they are established. The Commonwealth considers proposals for water use from a range of stakeholders, including state government organisations, and incorporates advice provided by the panel of scientific experts that make up the Environmental Water Scientific Advisory Panel.

## 2.4 System characteristics

### Hydrology

The physical form and condition of ecological values in the Yanco Creek system is shaped not only by the regulation of water, but by the spatial and temporal variability of this supply. That is, both physical form (the shape of the waterway) and ecological values such as fish and vegetation are driven by the hydrological behaviour of the system. In order to appreciate the Yanco Creek system ecology it is important to first understand the system hydrology, including both surface water, and groundwater-surface water interaction. One way to explore the system hydrology is to use a hydrological model. Unfortunately very little groundwater-surface water interaction information was available for the Yanco Creek System as a whole; however the hydrological model (described below) does comprise localised groundwater interaction (losses and gains) throughout the system.

Hydrological interactions along Billabong Creek were investigated in a 2011 report by NSW Office of Water that evaluated the connectivity and infiltration rates along Billabong Creek using a range of techniques (Brownbill et. al. 2011). Billabong Creek was identified as a losing-disconnected reach with an associated well-defined clogging layer near or slightly below the streambed (usually a clay unit 0.5 to 2 m thick, Brownbill et. al. 2011). Hydraulic conductivity in Billabong Creek was classified as low. Local river loss along Billabong Creek was estimated at around 15 to 16 thousand litres per kilometre per day for median and high (tenth percentile) river flows respectively. Regional losses were much lower at around 400 and 850 litres per kilometre per day for median and high river flows.

Two integrated water quantity and quality (IQQM) simulation models have been developed by NSW Office of Water for the Yanco Creek system water resources management planning: one for pre-development (or pre-regulated) conditions and one for current conditions. The IQQM models have been used to generate 100 years of flow data at various locations throughout the system under each condition. The pre-development flow series assumed no development over the entire 100 years (thus allowing direct comparison of the two conditions).

Using the modelled flow series, three key hydrological indicators have been developed: total annual flow, flow duration, and seasonality.

Total annual flow shows, on an annual basis, the quantity of water flowing through the Yanco Creek system under pre-development and current conditions and at various locations. This is a simple way of comparing the number of flow or no-flow, wet and dry years under each condition.

Flow duration illustrates the temporal variation of flows. For example, the flow duration curve can be used to understand the percentage of time that flows exceed 200 ML/d (or the percentage of time there is no flow at all, and so on) in any part of the system under pre-development and current conditions.

Seasonality shows what is driving the various flow-related ecological events tied to particular times of year, or seasons. For example, biological events such as fish migration and spawning which take place only if suitable flows occur and at the right time of year.

The below paragraphs summarise the hydrological behaviour of the Yanco Creek System.

### ***Total annual flow<sup>7</sup>***

Under current operating conditions the total annual flow is greatest in upper Yanco Creek between the off-take and Tarabah Weir (average 331 GL/y). This flow from the upper Yanco is split almost equally (on an annual basis) between middle Yanco Creek (average 150 GL/y) and Colombo Creek (average 145 GL/y). Unregulated Billabong Creek contributes on average 60 GL/year to the Colombo Creek flow, resulting in an increased total annual flow volume in middle Billabong Creek (average 205 GL/y). Downstream of the confluence of Yanco and Billabong creeks, the average total annual flow volume increases to 281 GL/y. Forest Creek has the lowest total annual flow (average 45 GL/y).

The total annual volume of flow prior to development was much lower than under current conditions. This is more pronounced in the upper reaches (ranging from three times less in middle Yanco Creek to seven times less in Colombo Creek) than in the lower reaches.

The pre-developed total annual flow volume generally follows the same temporal trend as for current conditions with two notable differences: the split between middle Yanco and Colombo Creeks is approximately two-thirds to one-third under pre-developed conditions; and the unregulated Billabong Creek contributes a greater proportion of flow to the lower reaches (29% of flow in middle Billabong comes from unregulated Billabong Creek, compared with 87% under pre-developed conditions). Under pre-development conditions years of no-flow are frequently observed (e.g. the early 1980s and for the whole of the 2000s).

Total annual flow is generally less variable under current conditions compared with pre-developed. For pre-developed conditions we frequently see average to high total annual flows followed by near no-flow years (and vice versa, for example years 1973 to 1974). Under current conditions the inter-annual variation is generally less pronounced. This represents quite a significant hydrological shift, most evident in reaches 1, 2 and 3, from what was a 'boom and bust' system to a more consistently flowing system. This in turn contributes to changes, both historical and ongoing, in geomorphological processes and system ecology.

Note: For ease of plotting, Figure 5 shows total annual flow from 1970-2009 only. The period from 1970-2009 exhibits both extreme wet (early 1970s) and dry (2000s) and is generally representative of the full record.

---

<sup>7</sup> Total annual flow is calculated by summing the total flow volume for each year of the record. Plots of total annual flow are used to show inter-annual variability and highlight dry, average and wet conditions. Pre-development and current conditions are easily compared using these plots

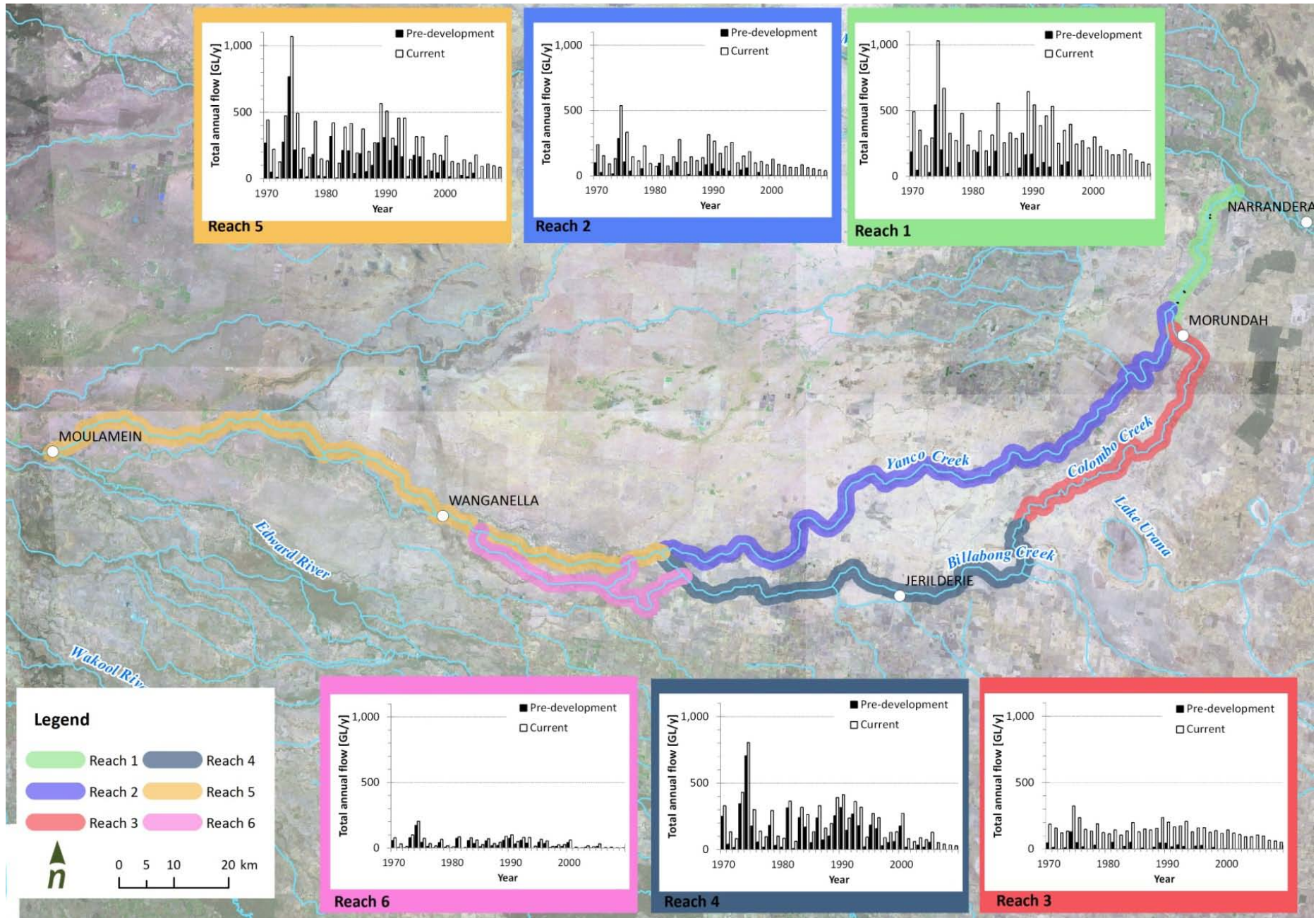

Figure 5. Modelled system wide total annual flow volume (1970-2009)



### **Flow duration curve<sup>8</sup>**

Under current conditions the magnitude of infrequent (flood) flows is greatest in middle and lower Billabong Creek (due to the catchment inflow influence of unregulated Billabong Creek). Infrequent (flood) flows are generally of the same or similar magnitude under current conditions and pre-developed conditions (except for Colombo Creek where current flood flows are approximately 50 % larger). Flood flows are greatest in middle and lower Billabong Creek (due to the catchment inflow influence of unregulated Billabong Creek).

Under pre-developed conditions the curves show that flows in the upper Yanco System (Reach 1, 2 and to some degree Reach 3) drop away to 'no-flow' for the majority of time, while under current conditions flows rarely if ever fall below 270 ML/d. The lower Yanco System (receiving inflows from unregulated Billabong Creek) exhibits greater variation in daily flows under pre-developed conditions with at least some flow observed right up to around 80 % of time (this is less notable in Forest Creek where flows persist only to around 30% of time). The lower Yanco System currently shows similar temporal variation in daily flows (shape of curve) as the upper system (except for Forest Creek where the flow duration curve is more closely matched with its pre-developed counterpart). Overall, reaches 1, 2, 3 and 6 show the greatest changes in no-flow, base flow, medium and high flows. Reaches 4 and 5 show a less pronounced change from pre-development to current conditions.

### **Seasonality<sup>9</sup>**

Flows in the Yanco System currently display a typical temperate seasonal pattern, with the lowest average monthly flows in February and March, and the highest average flows in August. For all reaches except Forest Creek there is at least some flow (i.e. not zero) on average, even in the lowest flow months. This should be noted in tandem with the flow duration curve discussion, above, where cease to flow events are markedly absent under current operation which is in direct contrast to the pre-development state. The distribution of daily flows under pre-development conditions for each month shows a similarly temperate seasonal pattern. However the magnitude of average daily flows is consistently smaller in all reaches (except Forest Creek where near pre-development daily flow magnitudes are observed).

The shift in seasonal variation from pre-developed to current conditions can be explored by quantifying the magnitude of variation between seasons. To do this we compare the average daily flow of the low and high flow months respectively. Under current conditions the greatest degree of variation is observed in Forest Creek where average daily flows in high flow months are significantly (roughly ten times) greater than low flow months. Reaches influenced by unregulated Billabong Creek (middle and lower Billabong Creek) are second most variable, while Colombo Creek (and to some degree upper and mid Yanco Creeks) show little variation between seasons. Under natural conditions the same trend is observed at each reach however the variation from low flow season to high flow season is markedly greater. For example in Forest Creek average daily flows in the high flow month is approximately 50 times greater in the lowest flow month (and between 20 and 25 times greater for middle and lower Billabong, and between 10 and 20 for upper and middle Yanco Creek and Colombo Creek). Interestingly, Colombo Creek is not the least variable reach (upper Yanco Creek is) under pre-developed conditions.

---

<sup>8</sup> Flow duration curves represent the ranking of all flows in the record from lowest to highest, where the rank is the percentage of time that the flow value is equalled or exceeded. These plots are used to show the percentage of time that the range of flow values are observed. Pre-development and current conditions are easily compared and contrasted using these plots

<sup>9</sup> Flow seasonality is calculated by averaging the daily flows observed in each month over the entire record. The plots show the pattern of variation, during the year, of the average daily volume of flows in each reach and is best demonstrated using a number of key statistics:

- The maximum and minimum flow values (average over all days in each month over the complete record)
- The mean flow value (average over all days in each month over the complete record)

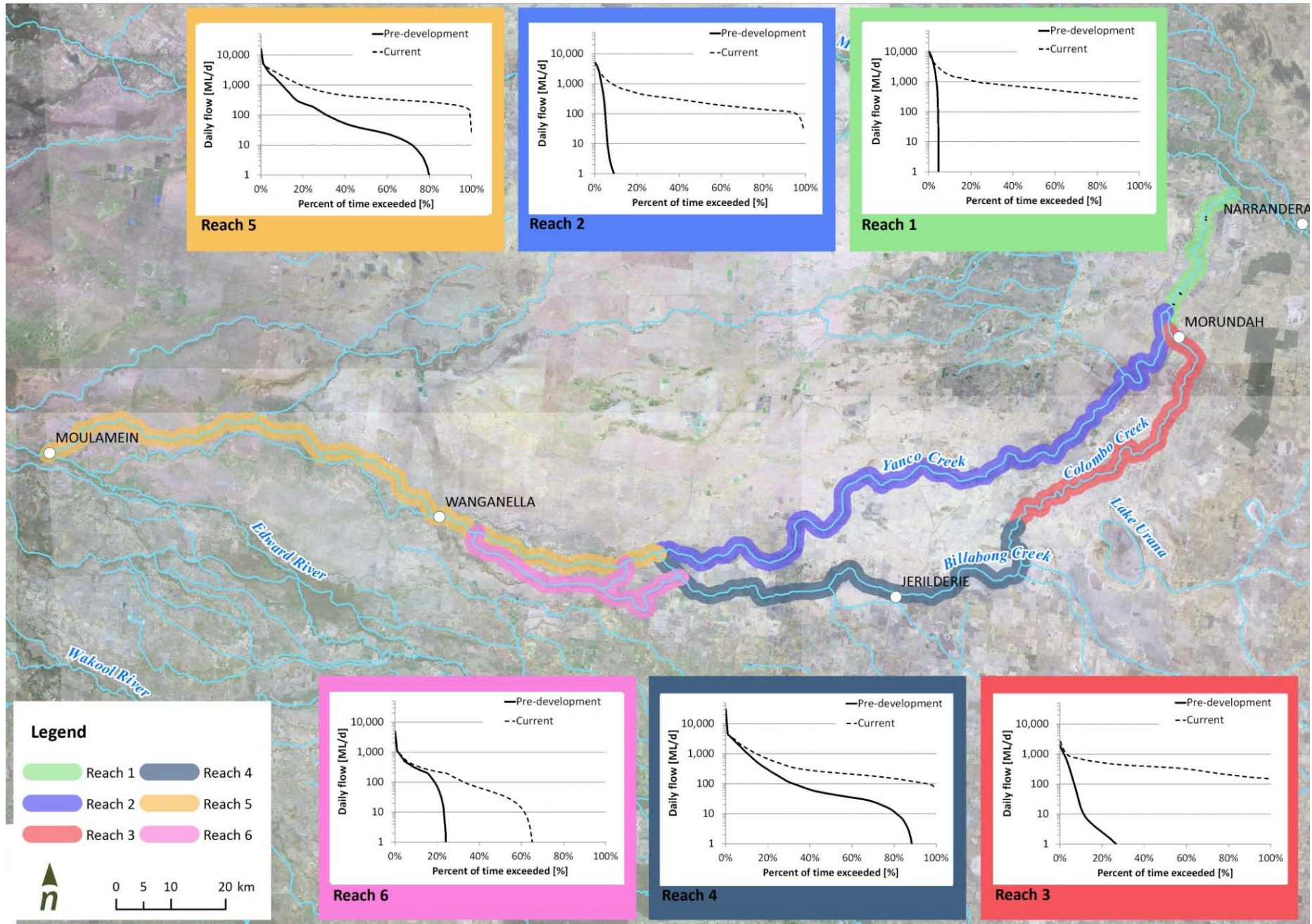

Figure 6. Modelled system wide flow duration curves

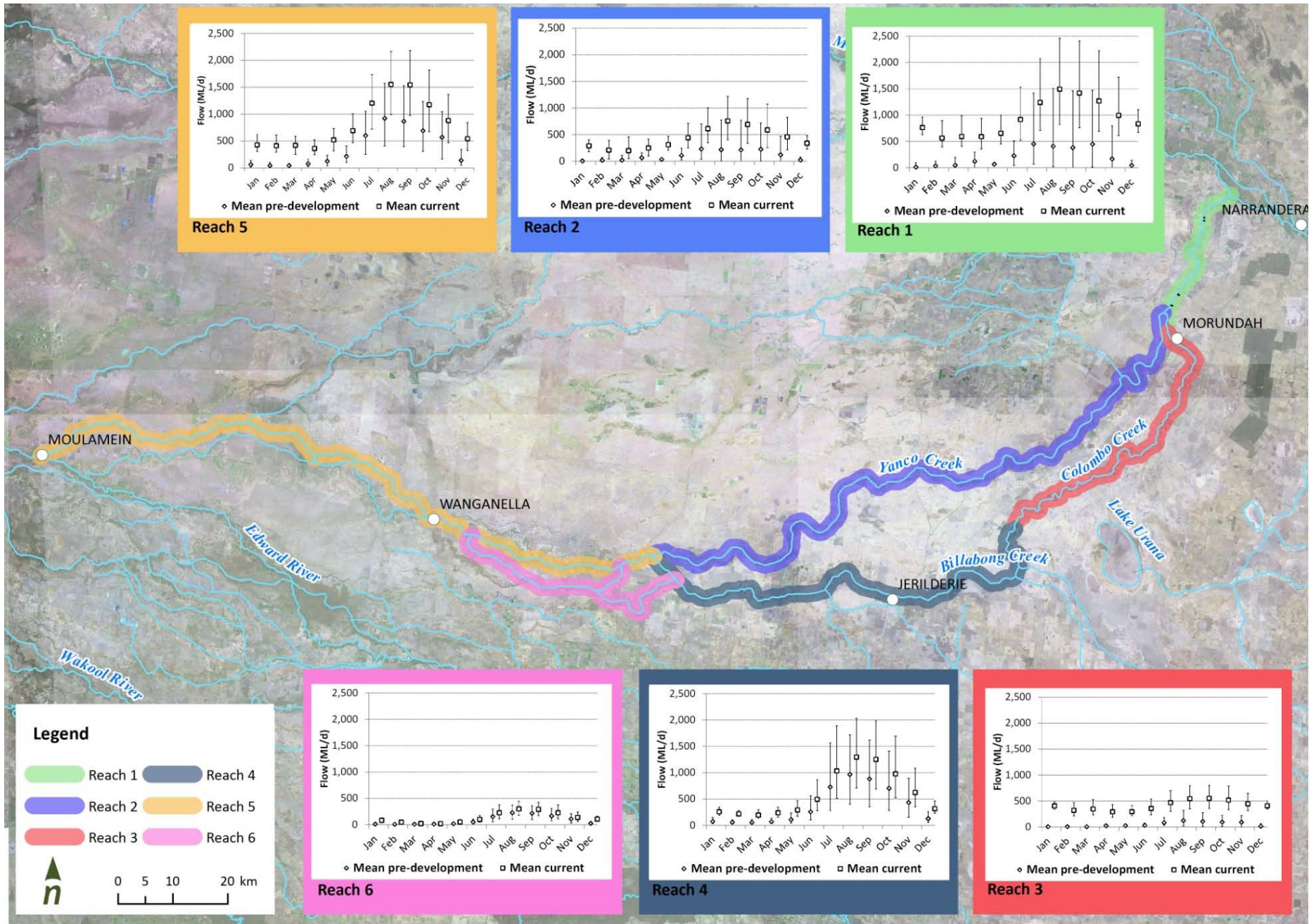

Figure 7. Modelled system wide seasonality plots

### Physical form

Physical form describes the size, shape and diversity of the river channel. A diversity of habitat types provides the physical basis for a diversity of biota and is an important factor in providing a healthy river. Understanding the history of the current geomorphic form and process of the Yanco Creek system is important for two reasons:

- It allows flows to be targeted at the geomorphic processes that threaten the achievement of the flow objectives (e.g. excessive sedimentation) or support the achievement of the objectives (e.g. provision of flows to maintain benches and pools).
- An understanding of the historic physical form and processes sets the current geomorphology in context and allows the likely future trajectory of change to be considered. For example, if part of the system is on a long-term trajectory of channel contraction, then this informs its likely utility as a means of transferring water into the future.

The Yanco Creek system lies within the lower tract of riverine plains of NSW, which covers the alluvial fans of the Lachlan, Murrumbidgee and Murray rivers west of the Great Dividing Range and extends down the Murray. Discharge from past and present streams control patterns of sediment deposition, soils, landscapes and vegetation. The riverine plains landscape is dominated by Quaternary river channels, floodplains, backplains, swamps, lakes and lunettes. The region comprises three overlapping alluvial fans centred on the eastern half of the Murray Basin. (Office of Environment and Heritage 2011).

Yanco Creek is part of a complex distributary system of paleochannels that emanates from the confined upstream valley at Narrandera (Page et al. 2009). Four sequential phases of paleochannel activity were identified by Page and Nanson (1996): Coleambally, Kerarbury, Gum Creek and Yanco. The present geomorphology of the Yanco system reflects its evolution through the Late Quaternary, with a number of (relatively) small, highly sinuous channels dominated by suspended sediment load (ie. low bedloads) within a large, very flat floodplain formed by the Yanco paleochannel that operated between 20,000 to 12,000 years ago.

The Yanco paleochannel was a powerful floodplain river, with an approximate bankfull width of 250 m (compared to approximate bankfull width of 35m in contemporary system). Bankfull discharge of the Yanco paleochannel is estimated to be between 4-8 times the current bankfull discharge (Page et al. 2009). The Yanco paleochannel was laterally unconfined, with well preserved, large wavelength and meanders (Figure 8), and scroll patterned floodplain formed by lateral migration (Page et al. 2009). The large source-bordering dunes associated with the Yanco channels show it carried large quantities of sandy bedload (Page et al. 2009).

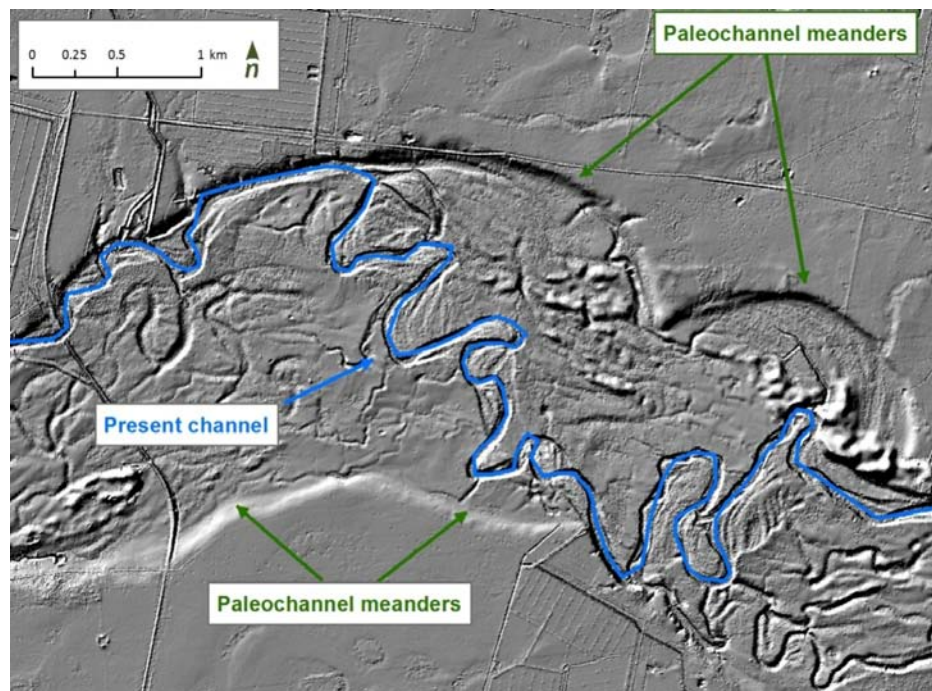

**Figure 8.** Comparison of present channel (blue) and paleochannel (green) planform in middle Yanco Creek (upstream of Cobb Highway)

The formation of the present geomorphology of the Yanco Creek is strongly influenced by the drier climate of the Holocene, which has resulted in the smaller, more sinuous pattern of the channels. In the lower section of the system there is a general floodplain gradient to the north so the floodplain flows generally towards Billabong Creek. Eight Mile Creek appears to be in active aggradation phase, which exacerbates the tendency for flows to move towards Billabong Creek, and reduces the effectiveness of this channel as a delivery route to Wanganella Swamp.

### Water dependent vegetation

All vegetation is, to some extent, dependent on a supply of water. Without water, plants, even those adapted to growth in deserts, eventually die. What *water-dependent vegetation* means in the context of this report is vegetation that lives in or near surface or groundwater, and in particular vegetation that is associated with flowing water such as rivers, streams and creeks, or with still water such as wetlands and billabongs.

A number of ways have been proposed to group different types of water-dependent vegetation. One is a structural approach, where plants species are grouped into broad categories such as forests and woodlands, shrublands, grasslands, sedgeland and rushlands, and herblands. A second is to sort the various species into functional groups, such as into terrestrial taxa (that do not tolerate flooding), submerged taxa (that do not tolerate drying), and the large intermediate group of amphibious taxa (that tolerate both flooding and drying). A third method has been to divide the plants up into broad taxonomic associations, such as Black Box woodlands, River Red Gum woodlands or forests (the difference between forest and woodland depends mostly on canopy cover and tree size and density), Lignum shrublands, reed beds, and general aquatic associations of obligately submerged taxa, such as *Vallisneria*. The different approaches have various strengths and weakness, and which one is better often depends on the types of questions that need to be answered, or in this study, the environmental objectives that are set.

Our field inspections and the available literature indicated that there is very little submerged aquatic vegetation in the Yanco System. In most inland rivers in New South Wales, one would expect to find submerged taxa such as *Vallisneria* and *Potamogeton*. Species such as these, however, seem to have been progressively lost since the 1950s and particularly since the expansion of carp in the 1970s. The only exception to this generalisation occurs in unregulated Forest Creek, where a localised community of instream (and emergent) vegetation had evolved in response to the hydrological conditions at this site, probably enhanced by fencing and related restrictions on stock access (Figure 9). At this site, maintenance of the existing diverse range of submerged and emergent plant species could be considered a high priority.



**Figure 9.** Instream and emergent vegetation observed in unregulated Forest Creek at Peppinella (image taken 20 June 2012)

In contrast to the general case with instream vegetation, the river system supports in most places a band of riparian vegetation on the banks and higher benches, dominated almost entirely by River Red Gum (*Eucalyptus camaldulensis*) on those parts likely to be inundated more frequently, and Black Box (*Eucalyptus largiflorens*) on slightly higher ground that receives less frequent and shorter inundation. The density of trees and the resultant density of canopy cover vary for River Red Gum stands, from sparse woodland in drier sites to, more

rarely, a dense forest with larger trees and more canopy cover in wetter sites. In a few locations, River Cooba (*Acacia stenophylla*) is present as a canopy-forming tree; flooding is important for this species in order to maintain adult trees, but it is not clear what role periodic inundation has in the species' recruitment.

The width of the riparian zone varies greatly over the study area, from over a kilometre in some locations to narrow bands only a tree or two wide in others. This variation is a result of two factors:

- a geomorphological factor, resulting in differences in the width of the floodplain and higher-level benches across the site
- a land-management factor, the impact of stock grazing, mostly by sheep, on the recruitment of young trees into the population.

The adverse impact of stock access is strongly evident in parts of Reach 4a, middle Billabong Creek, where the water regime is most natural of all parts of the system but the riparian zone is in very poor condition where stock have unlimited access to the stream and its bankside vegetation (Figure 10a).

Although the riparian zone has a canopy layer consisting of mostly either River Red Gum or Black Box, or more rarely River Cooba, there are also important understorey species present as well. In many cases, the understorey condition is limited, probably as a result of grazing pressures. In those spots where grazing does not occur (e.g. near Devlins Bridge in Reach 1, and in parts of Old Corree in Reach 4b, Figure 10b), the understorey is dense and floristically diverse. It can include a range of native grasses, rushes and sedges and, conspicuously, lignum (*Muehlenbeckia florulenta*).

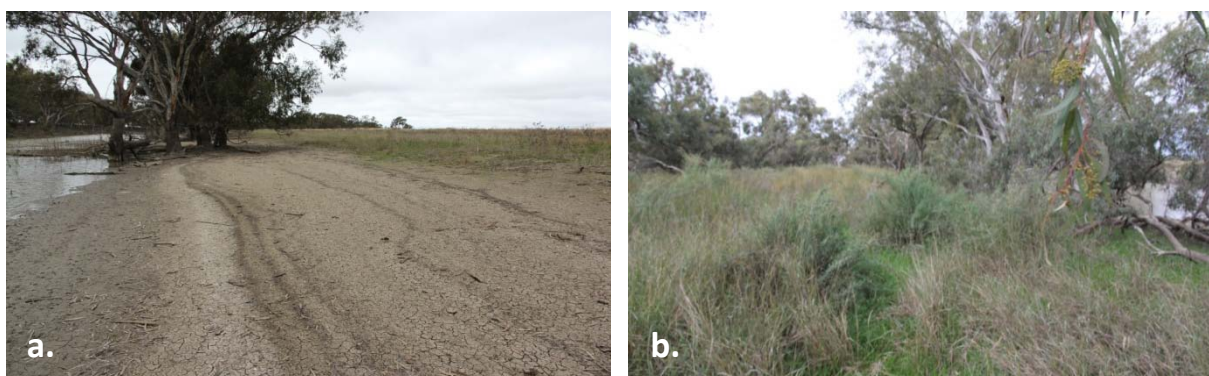

**Figure 10.** Differences in riparian vegetation in Middle Billabong Creek - Billabong Creek upstream of Jerilderie (a) and at Old Corree downstream of Jerilderie (b) (images taken 21 June 2012 (a), 22 June 2012 (b))

The third type of water-dependent vegetation found in the study area is the reeds, rushes and sedges that occur along the river banks and on its benches or in shallow water in the stream margins. These seem to have a restricted distribution, probably as a result of relatively unchanging water levels in many of the waterways. Emergent taxa such as these commonly grow best when water levels fluctuate on a seasonal basis, with high water levels in winter and spring and low water levels in summer. Constant high water levels, especially when the water is enriched with plant nutrients such as phosphorus, differentially encourage the growth of Cumbungi (*Typha* spp.), and this process was evident at a number of sites in the study area (Figure 11).

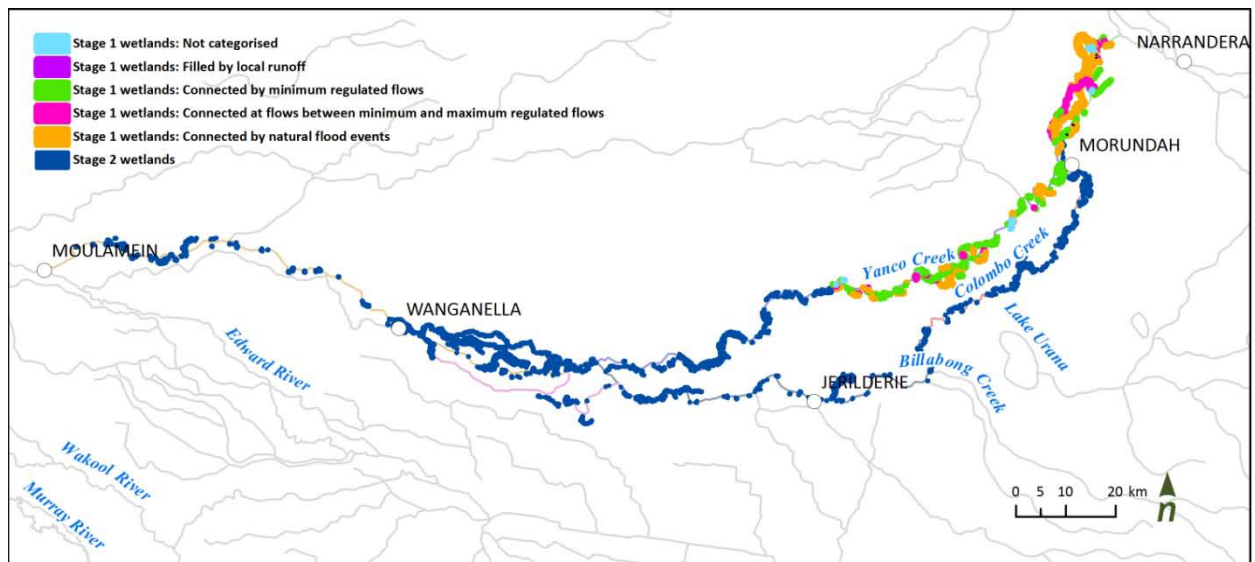

**Figure 11.** Cumbungi (*Typha* spp.) present in Colombo Creek at Urana-Jerilderie Rd (image taken 18 June 2012)

## Floodplain wetlands

A wide range of floodplain wetlands are present in Reach 1, the upper Yanco, including the Possum Creek complex, Dry Lake and Mollys Lagoon, and the Washpen Creek complex (Figure 12). These are characterised by large expanses of open water that may or may not support obligately submerged vegetation<sup>10</sup>, and are fringed mostly by River Red Gum. Reach 6, Forest Creek, also supports the regionally important Wanganella Swamp and Rhyola wetland. Of these, Wanganella Swamp is the more floristically diverse and its water-regime requirements have been addressed in a number of prior studies.

In addition to these large and visually obvious floodplain wetlands, the Yanco system supports a large number of smaller floodplain depressions and billabongs (Figure 12). What is important in the maintenance of floodplain wetlands is to take advantage of subtle variations in the elevation of the various wetlands and their commence-to-flow rates. In this way, a mosaic of wetlands can be maintained in different stages of wetting and drying, by providing overbank flows or bankfull flows to engage flood runners. The overall ecological resilience of the system is enhanced by providing hydrological conditions that facilitate the maintenance of such a mosaic of wetlands under different hydrological regimes. It is worth mentioning too that, in all cases, the maintenance of floodplain wetlands depends not only on hydrological factors but also on land-use practices. In general, wetland plants cannot recruit successfully when subject to high and constant grazing pressure, and the maintenance and rehabilitation of the system's complex array of wetlands (large and small) will require ancillary actions involving catchment management as well as the provision of environmental water.



**Figure 12.** Wetlands mapped in the Yanco Creek system through two previous projects –Investigation into potential water savings from the Yanco Creek system (off-take to Yanco Bridge) wetlands (Webster 2007) (referred to as Stage 1), and the follow-on Stage 2 study (GIS data only, Webster unpublished)

## Fish

Yanco Creek has a diverse fish community, with at least 14 native species, in the system and adjoining Murrumbidgee River (Baumgartner 2007; Lintermans 2007). Seven species (e.g. Murray Cod, Trout Cod, Silver Perch, Southern Pygmy Perch, Freshwater Catfish, Olive Perchlet and Flat-headed Galaxias) have high conservation significance and are listed as “threatened” under the Fisheries Management Act 1994 and the Commonwealth EPBC Act 1999. The most common species are the small-bodied fish such as Australian Smelt, Unspecked Hardyhead, Murray Rainbowfish and Carp Gudgeons (Wassens et al. 2012) that are also common elsewhere in the lowlands of the Murrumbidgee River catchment (Gilligan 2005). The large and medium bodied fish species are also present, including Murray Cod, Trout Cod, Golden Perch, Silver Perch, Bony Herring and Freshwater Catfish. Along with small-bodied fish, there is some evidence for recruitment of Golden Perch in the large floodplain lakes, such as Dry Lake and Mollys Lagoon (Wassens et al. 2012). A further five non-native species are also present in Yanco Creek, including: Carp, Gambusia, Goldfish, Redfin Perch and Oriental Weatherloach.

<sup>10</sup> Plants permanently submerged; produce floating, aerial or submerged reproductive organs; including floating-leaved plants.

Table 7 outlines the fish species recorded in the Yanco Creek system, and those species expected to occur.

**Table 7. Fish species recorded (rec) and expected (exp) to occur in study reaches of the Yanco Creek system, based on combination of site visit and NSW Fisheries Data for the Yanco Creek system. Note: native large-bodied fish = ■<sup>L</sup>, native medium bodied fish = ■<sup>M</sup>, native small bodied fish = ■<sup>S</sup>, native small bodied floodplain specialist fish = ■<sup>F</sup>**

Common name	Native	Exotic	Reach 1		Reach 2		Reach 3		Reach 4		Reach 5		Reach 6	
			Rec	Exp	Rec	Exp	Rec	Exp	Rec	Exp	Rec	Exp	Rec	Exp
Murray Cod#	<span style="color: green;">■</span> <sup>L</sup>		✓	✓	✓	✓	✓	✓	✓	✓		✓		
Trout Cod#	<span style="color: green;">■</span> <sup>L</sup>		✓	✓		✓								
Golden Perch	<span style="color: green;">■</span> <sup>M</sup>		✓	✓	✓	✓		✓	✓	✓		✓		
Silver Perch#	<span style="color: green;">■</span> <sup>M</sup>		✓	✓	✓	✓		✓		✓		✓		
Murray Rainbowfish	<span style="color: green;">■</span> <sup>S</sup>		✓	✓		✓		✓		✓		✓		
Freshwater Catfish	<span style="color: green;">■</span> <sup>L</sup>			✓		✓		✓	✓	✓	✓	✓		✓
Bony Herring	<span style="color: green;">■</span> <sup>M</sup>		✓	✓		✓		✓		✓		✓		
Carp Gudgeons	<span style="color: green;">■</span> <sup>S</sup>		✓	✓		✓	✓	✓	✓	✓		✓		✓
Un-Specked Hardyhead	<span style="color: green;">■</span> <sup>S</sup>		✓	✓		✓		✓	✓	✓		✓		
Australian Smelt	<span style="color: green;">■</span> <sup>S</sup>		✓	✓		✓	✓	✓	✓			✓		
Flat-headed Gudgeon	<span style="color: green;">■</span> <sup>S</sup>		✓	✓		✓		✓		✓		✓		✓
Dwarf-Flathead Gudgeon	<span style="color: green;">■</span> <sup>S</sup>			✓		✓		✓				✓		
Olive Perchlet#	<span style="color: green;">■</span> <sup>F</sup>								✓	✓		✓		✓
Mountain Galaxias	<span style="color: green;">■</span> <sup>F</sup>													
Flat-headed Galaxias#	<span style="color: green;">■</span> <sup>F</sup>			✓		✓								
Southern Pygmy Perch #	<span style="color: green;">■</span> <sup>F</sup>			✓		✓								
Gambusia		■	✓	✓		✓	✓	✓	✓	✓		✓		✓
Goldfish		■	✓	✓		✓	✓	✓	✓	✓		✓		✓
Oriental Weatherloach		■	✓	✓		✓		✓		✓		✓		✓
Common Carp		■	✓	✓	✓	✓	✓	✓	✓	✓		✓		✓
Redfin Perch		■	✓	✓			✓	✓		✓		✓		✓

Note: expected for reach 6 is at Wanganella Swamp

Yanco Creek, particularly the upper section, provides good habitat for a range of native fish species because the annual irrigation flows provide hydraulic diversity among the various habitats within the creek. An example of the hydraulic diversity might be relatively shallow areas with faster flow and deeper slow flowing pools. The second habitat aspect is the relatively high abundance of physical habitat such as snags, particularly in the upper reaches. Regular connection with the adjacent floodplain wetlands also provides habitat diversity for the floodplain fish species.

### Macroinvertebrates

The term aquatic macroinvertebrates refers to a diverse group of non-vertebrate animals found in the river channel. This includes animals such as insects (e.g. groups such as mayflies, caddisflies, and beetles), crustacea (yabbies, amphipods), dipterans (fly larvae such as chironomids), aquatic snails and aquatic worms. Macroinvertebrates form an important component of the aquatic ecosystem, both as part of the natural biodiversity and as a vital component of the food chain (they form the major component of the diets of most native fish).



The major determinants of the abundance and composition of the aquatic macroinvertebrate fauna are the flows, available habitat, sources of food and water quality. In the main, the key habitats for macroinvertebrates in lowland rivers are the benthic sediments, instream vegetation and woody debris in the channel. An additional habitat in lowland rivers is the zone of tree roots along the edge of the channel. These roots provide shelter from high flows and predators, trap leaves and other organic debris in which the macroinvertebrates live.

The major food sources for most macroinvertebrates are algae, biofilms (layers of bacteria and other microorganisms that cover elements in the water) and terrestrial organic material (leaves, twigs etc) that fall into the stream from the riparian zone.

Very little is known of the diversity and composition of the macroinvertebrate fauna of the Yanco Creek system. Only one record of a survey, at a single site on the Yanco Creek at Morundah in 1998 (Reach 2), could be located. The fauna at that site was typical of lowland rivers, with species associated with snags (e.g. freshwater prawns, beetles and shrimps), aquatic plants (e.g. caddisflies and shrimp), relatively slow-flowing open water (e.g. water bugs) and fine sediments (e.g. freshwater worms). It would seem likely that similar types of communities would be prevalent throughout the remaining parts of the system due to the types of habitats that can be found elsewhere.

However, Yanco Creek lies in the area covered by the listed “Lower Murray Aquatic Ecological Community” (NSW DPI 2007). The lower Murray aquatic ecological community includes all native fish and aquatic invertebrates within all natural creeks, rivers and associated lagoons, billabongs and lakes of the regulated portions of the Murray, Murrumbidgee and Tumut rivers, as well as all their tributaries and branches (including Yanco Creek). The community includes 23 native fish species and over 400 recorded native invertebrate species (although all native fish and other aquatic animal life within its boundaries are accorded the status of endangered species).

### 3 Environmental objectives

Environmental objectives were determined by the Technical Panel and Steering Committee for each study reach. The objectives reflect the environmental values identified throughout the system by the community (during community information sessions held in May 2012), through literature review, and assessment by the Technical Panel. Objectives were determined in the context of current water resource management, and the social and economic values of the region. The environmental objectives are summarised in Table 8 and discussed in further detail in this section.

**Table 8. Environmental objectives for the Yanco Creek system**

Environmental objective	Reach*							
	1	2	3	4a	4b	5	6a	6b
Maintain riparian vegetation condition, extent and composition	■	■	■		■	■	■	■
Rehabilitate riparian vegetation condition, extent and composition				■				
Maintain diversity and abundance of instream vegetation								■
Maintain a mosaic of wetlands	■	■			■	■		■
Maintain channel form and promote habitat diversity	■	■		■		■		■
Maintain drought refuge habitat			■		■		■	
Support self sustaining populations of macroinvertebrate taxa from the endangered Lower Murray Aquatic Ecological Community	■	■	■	■	■	■	■	■
Support self sustaining populations of macroinvertebrate taxa found in mid-Murrumbidgee wetlands	■	■	■					
Maintain and/or improve large-bodied native fish community	■	■	■	■	■	■	■	
Maintain and/or improve medium-bodied native fish community	■	■	■	■	■	■	■	
Maintain and/or improve small-bodied generalist native fish community	■	■	■	■	■	■	■	■
Maintain and/or improve small-bodied native fish – floodplain specialists	■	■				■		■

\* Yanco Creek System reaches include:

Upper Yanco Creek	From Yanco off-take to Sheepwash weir pool (Colombo Creek)
Mid Yanco Creek	From Tarabah Weir to confluence with Billabong Creek
Colombo Creek	From Sheepwash weir pool to Cocketgedong weir
Mid Billabong Creek	Cocketgedong weir to Yanco Creek confluence (sub-reach 4a upstream of Jerilderie, sub-reach 4b downstream of Jerilderie)
Lower Billabong Creek	Downstream of Yanco confluence
Forest Creek	Regulated (sub-reach 6a) and unregulated (sub-reach 6b) sections

For every environmental objective, the Technical Panel have defined the characteristics of flows required to achieve the objectives and the hydraulic criteria to measure achievement. These hydraulic criteria were applied during the environmental flow determination (Section 4).

### 3.1 Maintain and/or rehabilitate riparian vegetation condition, extent and composition

#### Description

Riparian vegetation plays a crucial role in the ecological structure and function of streams in inland Australia. Living trees provide habitat for a wide range of animals, ranging from small invertebrates (e.g. insects) to large vertebrates, including water- and bush-birds. Fallen limbs and bark provide habitat and shelter for animals on the floodplain floor, especially invertebrates and reptiles. Wood that falls into the stream similarly provides habitat for aquatic animals, especially fish. Leaf fall and bark shedding provide organic matter that fuels floodplain and aquatic food webs, mostly via decomposition and consumption by macroinvertebrates. The larger trees shade the stream, lowering water temperatures and providing shade for fish. Smaller plants, such as shrubs and other elements of the understorey, also protect the soil against erosion during floods and during heavy storms. Finally, the plants provide a critical aesthetic element that makes Australian streams and creeks look the way they do.

The wording of the environmental objective needs to be teased out, from two perspectives. First, there is a difference between maintaining and restoring/rehabilitating the values. Maintenance refers to actions that are intended to preserve existing values. In contrast, rehabilitation intends to improve those values to some pre-agreed end point. Some people draw the distinction between rehabilitation (improving condition of a value towards a target that is not necessarily pre-European) and restoration (returning it to a pre-European condition). It is a distinction worth preserving.

Second, the value that we are talking about here is riparian vegetation in its entirety. This includes not only the adult trees, but aspects of their condition or health, species composition of the canopy layer and of the understorey, and the ecological processes that allow the community to persist in time in a sustainable way. In other words, the environmental objective is not merely to maintain 'x' number of large trees per hectare, but to ensure that the plants are in good condition, that the floristic diversity is appropriate for the site and its intended uses, and that young plants can recruit into the population in order to replace those older ones that will eventually die. The last process is a crucial element, as there are many locations in the Yanco System where stock access means that young plants cannot survive (e.g. eaten or trampled), and thus eventually the entire community will be lost as the older specimens die out.

#### Relevant reaches

Where the current condition of riparian vegetation is good, the environmental objective is to 'maintain' the current condition, extent and composition of riparian vegetation. This objective applies to reaches 1, 2, 3, 4b, 5, 6a and 6b. In reaches with poor riparian vegetation condition (Reach 4a), the objective is to 'rehabilitate' instead of 'maintain'.

#### Flow objectives

The water-regime requirements of different plant species that occur in the Yanco System are summarised in Table 9. This table shows the known water-regime requirements for the four dominant riparian, aquatic and floodplain plant taxa in the Yanco Creek system. Note that there is inevitably some inconsistency among the various data sources for given plant taxa, and the table seeks to find a 'common ground' where recommendations are not the same.

**Table 9. Summary of water regime requirements of structurally dominant riparian and floodplain plant species<sup>11</sup>. *Vallisneria* spp. are used as a type-species for submerged taxa.**

Component of water regime	<i>Vallisneria</i> spp. (eelgrass, tape grass, vallis)	River Red Gum	Black Box	Tangled Lignum
Ideal time	Annual (or if variable, inundation in winter-spring to allow for successful recruitment)	August-December	Not known for adults, but recession in spring-summer likely to be beneficial to seedlings	Not well known for adults—possibly summer-autumn. Autumn-winter required for recruitment of young plants.

<sup>11</sup> table based on information from diverse sources, including Murray-Darling Basin Commission (1992), Roberts and Marston (2000, 2011), Murray Flow Assessment Tool (Young *et al.* 2003), Victorian Environmental Assessment Council (2006) and Rogers (2011).

Component of water regime	<i>Vallisneria</i> spp. (eelgrass, tape grass, vallis)	River Red Gum	Black Box	Tangled Lignum
Frequency to maintain adults				
Natural average	Annual	4–9 years/decade	2–3 years/decade	2–5 years/decade
Minimum required	Annual	3–7 years/decade	1–2 years/decade	1–3 years/decade
Duration to maintain adults				
Natural average	9-12 months	1–5 months	2–6 months	3-7 months
Minimum required	> 9 months	0.5–1 month	1–2 months	1–3 months
Maximum period between floods to maintain adults	0 months	<6 years	<5–10 years	<5 years
Maximum period of inundation	Constant	<18 months	<4 months	Not known
Requirements for recruitment of young plants	Not well known. Can reproduce sexually and asexually. Water depths probably <2 m	Large flood in winter or spring, followed by wet winter-spring or shallow summer flooding. Inundation in subsequent years	Not well understood. Seedlings cannot tolerate inundation for >~2 months. Ideal inundation period is probably < 1 month. Poor recruitment has been noted across the M-D Basin for many decades.	Inundation for 10–40 days. Note adults are intolerant of prolonged inundation. Inundation timing is crucial for recruitment, as seeds need to germinate soon after release (in autumn).
Notes	Requires water >50 cm in summer to avoid thermal damage to leaves. Water otherwise <2 m to keep leaves in photic zone.	Optimal water regime varies from forests (more frequent and longer) to woodlands (less frequent and shorter). Follow-up floods improve recruitment.	Adults can tolerate a wide range of wet-dry conditions, and the understory is could be an important factor is devising the most appropriate regime for a given site.	Larger shrubs require longer inundation than smaller specimens. Shallow water (<15 cm) required for recruitment.

For some species (e.g. River Red Gum), periodic inundation is required to maintain adults in good condition and to allow seedlings to establish. River Red Gum, for example, requires inundation in August to December for between 1 and 5 months and at a frequency of between almost every year to three-or-four times per decade. Subtle differences in water regime will contribute to differences in the density of the stand, with more frequent watering tending to give rise to forests and less frequent watering tending to give rise to woodlands, other things being equal. In contrast to River Red Gum, Black Box requires inundation only 2–3 times per decade, seemingly without the seasonal element of winter-spring timing being so important, and can survive periods without watering of up to 10–20 years, albeit with serious decreases to tree health. Criteria such as these were used to inform the calculation of flow recommendations that aimed to provide hydrological conditions that would maintain healthy communities of riparian vegetation<sup>12</sup>.

Hydrological requirements such as these are suitable for the maintenance and restoration/rehabilitation of riparian vegetation, but bankfull and overbank flows serve other ecological functions as well. For example, they entrain organic debris that has accumulated on the banks and on the floodplain into the river, thus providing aquatic fauna with a food supply. It is assumed that the frequency, duration and periodicity of overbank flows required to maintain riparian vegetation is sufficient also for these other ecological processes as well.

<sup>12</sup> The dry periods between flows is also important to maintain vegetation health

Different criteria are required to maintain submerged and emergent vegetation that grow in the stream channel and on the stream benches. In these cases, the plants of interest are either obligately aquatic (e.g. *Vallisneria* and *Potamogeton*) or else are mostly emergent reeds, rushes and sedges (e.g. *Phragmites*, *Juncus*, *Eleocharis* etc).

The idea behind providing these types of flows for submerged and emergent vegetation is two-fold. First, there is the requirement to provide periodic watering to maintain emergent taxa. Most require episodic flooding over summer to keep the soil wet. There is good evidence that fluctuating water levels also promote the growth of desirable taxa of emergent plants, such as *Phragmites* and *Eleocharis*, over less desirable *Typha*. It was this consideration that informed the decision to aim for fluctuations of 0.1–0.2 m for the required inundation events for emergent plants species on benches and in shallow the floodplain wetlands closely associated with the river. Second, periodic inundation prevents colonisation of the stream channel and benches by terrestrial plants, especially agricultural weeds. Benches that are not inundated for long periods over winter become quickly colonised by terrestrial taxa: the winter inundation is aimed at drowning out and preventing the colonization of aquatic habitats by non-aquatic plant species. In the case of the streambed, a minimum depth of 0.5 m required for submerged plants will also prevent the colonization of the stream by terrestrial taxa.

### 3.2 Maintain diversity and abundance of instream vegetation

#### Description

The water-dependent vegetation in unregulated Forest Creek (Reach 6b) differs substantially from that in other parts of the Yanco system. Although there is still a (narrow) riparian zone of River Red Gum, Black Box and River Cooba, a valuable component in Reach 6b is the mosaic of submerged and emergent vegetation that has developed in the stream channel and in the very shallow areas that fringe it. In this case, the environmental objective is to maintain the abundance and diversity of the instream and fringing vegetation. As noted above, submerged and emergent vegetation was not an obvious feature of other reaches, except when stock access had been controlled (e.g. in small parts of Reaches 1 and 4)

#### Relevant reaches

This environmental objective is only applicable to Reach 6b (unregulated Forest Creek).

#### Flow objectives

The thinking behind setting flow objectives for Reach 6b mirror closely those outlined above for the other reaches in the system, with the exception that greater emphasis is given to those components of the flow regime required to maintain obligately aquatic vegetation and emergent taxa. The same criteria of a minimum water depth (0.5 m) to provide adequate habitat for submerged taxa and to prevent colonization by terrestrial taxa apply here as well. Similarly, a requirement for periodic inundation of benches via a fluctuating water regime is designed to facilitate the growth of a diverse range of emergent and amphibious taxa, such as reeds, rushes and sedges.

### 3.3 Maintain a mosaic of wetlands

#### Description

To maintain a mosaic of wetlands of different size, shape and depth, and with different water regimes, ranging from ephemeral to near-permanently inundated, flow regimes for the floodplain wetlands will need to vary. The flow regime will need to include a range of commence to flows and inundation periods, in order to provide the various wetting and drying cycles needed to support fringing River Red Gum (i.e. inundation every 1–5 years, over spring–summer) to the far less frequent inundation required for Lignum (i.e. inundation only 1–3 times per decade). Table 10 summarises the available information on environmental water requirements to maintain broad groups of aquatic plants in wetlands of south-eastern Australia.

**Table 10. Hydrological requirements to maintain broad groups of plant types in wetlands of the Murray-Darling Basin.** Sources: <sup>A</sup> Victorian Environmental Assessment Council (2006, Table 5.6) and <sup>B</sup>Rogers (2011, Table 2.5). NP = information not provided in sources

Group	Typical species	Water regime			
		Frequency of inundation	Duration of inundation <sup>13</sup>	Timing of inundation	Depth of inundation
Submerged angiosperms <sup>B</sup>	<i>Vallisneria</i> spp. <i>Triglochin</i> spp.	Annual	12 months	Spring to summer	50-100 cm (Permanently flooded)
Rushes and sedges <sup>B</sup>	<i>Eleocharis</i> spp. <i>Cyperus</i> spp.	Annual	2-4 months	Spring to summer	+ 20 cm Fluctuating water levels with regular flooding and drying)
Reeds <sup>B</sup>	<i>Phragmites australis</i> <i>Eleocharis</i> spp. <i>Cyperus</i> spp.	Annual	6 months	Spring to summer	+ 30 cm (Shallow fluctuating and drying)
Cumbungi <sup>B</sup>	<i>Typha</i> spp. <i>Juncus</i> spp. <i>Eleocharis</i> spp.	Annual	9-12 months	Spring to summer	0-200 cm (Permanent to regular flooding with some depth)
Rushlands <sup>A</sup>	<i>Juncus</i> spp.	7-10 years per decade	2-10 months	July to January	Not indicated
River Red Gum forest <sup>B</sup>	<i>Eucalyptus camaldulensis</i>	1 in 3 years	2-6 months	Spring to summer	NP
River Red Gum woodland <sup>B</sup>	<i>Eucalyptus camaldulensis</i>	1 in 3-5 years	2-4 months	Spring to summer	NP
Black Box woodland <sup>B</sup>	<i>Eucalyptus largiflorens</i> <i>Acacia stenophylla</i>	1 in 10 years	2 months	Summer to autumn	NP
Tangled Lignum <sup>B</sup>	<i>Muehlenbeckia florulenta</i> <i>Atriplex</i> spp.	1 in 3-10 years	1-6 months	Summer to spring	60 cm

### Relevant reaches

The objective to maintain a mosaic of different wetland types is relevant to reaches 1, 2, 4b, 5 and 6b.

### Flow objectives

The first generic recommendations for wetting and drying cycles in floodplain wetlands of inland NSW were established by Briggs (1988). Her preliminary recommendations can be rounded out by including the findings of research undertaken in the lower Murray-Darling Basin in the intervening two decades (e.g. Walker, Thomas & Sheldon 1992; Walker 2006; Boon et al. 2009 etc). On this basis, we propose the following seven generic principles for floodplain wetlands in inland south-western NSW where the intention is to return them to an ecological condition that most resembles that occurring in pre-European times:

<sup>13</sup> Duration of inundation relates to the period and frequency that water can/should remain on the floodplain in wetland depressions, based mostly on conditions needed for River Red Gum and to a lesser extent for other emergent wetland plants that occur in wetlands (e.g. rushes and reeds) and for the maintenance of sediment biogeochemistry. The duration of inundation would be achieved by bankfull or overbank flows that fully wet the top of the bank and go out into the floodplain to various degrees (depending on elevation) and which then fills floodplain depressions, wetlands etc. The accumulated water on the floodplain and in wetlands then slowly evaporates or drains into the subsoil until it is 'dry' (i.e. lack of surface water) before the next flood and the next inundation period starts all over again.

The 'duration' of the environmental flow recommendations outlined in this report are instead, the number of days that the flow in the river is expected to occur at that magnitude to provide for plant health and recruitment for RRG in the riparian zone, for wetlands in floodplain depressions, and for Black Box on higher parts of the floodplain.

- Maintaining stable, high water levels is generally incompatible with the maintenance of high ecological values
- Water levels need to fluctuate seasonally
- Temporary wetlands require periodic inundation, with periodic drawdown of water levels and complete drying
- Wetlands should be flooded in late winter or early spring, and remain inundated for at least three to eight months.
- Rates of inundation and drawdown need to be controlled
- Multiple wetting-drying cycles may be required for environmental rehabilitation
- Ecological connectivity among wetlands should be acknowledged and maximised

A full description of these principles is provided in Attachment B of this report. The principles apply to situations where it is desirable – and possible – to modify water regimes to rehabilitate floodplain wetlands, however there are a number of situations when altering a wetland’s water regime is not advised, or at least should be undertaken with great caution (Boon et al. 2009). Examples include when:

- potential or active acid sulfate soils are present
- the wetland lies over shallow saline groundwater
- there is the possibility of saline intrusions from adjacent saline water bodies
- a high-value wetland system has evolved in response to chronic inundation
- the introduction of a dry phase may lead to unexpected and undesirable changes in land use.

In the Yanco System, the greatest risk is to attempt to impose an ephemeral water regime on wetlands that have been permanently inundated, often for decades. The desired mosaic of wetland types is to produce the same mosaic of wetland types rather than restoring the pre-European condition of each wetland. Importantly, current permanent wetlands may be retained as permanent if they are in good condition. Likewise ephemeral wetlands may be less ephemeral and vice versa. Largely the basis of the wetland mosaic is maintaining the current condition if it is seen to be in good condition.

Significant ecological risks may be incurred with attempts to implement a drying phase in wetlands that have been chronically inundated and in which a particular and valued biota has established itself over time. Since river regulation and extraction have been undertaken for over a century along the Murray, Murrumbidgee and lower Darling Rivers, it is possible that over time permanently inundated wetlands have evolved ecological communities that are now of high ecological value. Even though the re-instatement of a more natural wetting and drying regime may seem theoretically desirable, in such cases any hydrological change from existing conditions may have undesirable ecological consequences. Boulton and Brock (1999, p 150) noted that ‘Drying of a permanent wetland usually extinguishes most of the aquatic biota and recovery is much slower than in nearby naturally temporary wetlands’. For example, long-established populations of native fish and amphibians could be compromised by the reintroduction of a drying phase in chronically inundated wetlands.

There may also be impacts on wetland plants, of which adverse effects on obligately submerged species are likely to be the most significant. Ellis and Meredith (2005), for example, reported that submerged angiosperms (e.g. *Vallisneria* spp.) could be killed by drying a wetland and may fail to recolonise it upon reflooding. The following section summarizes what is known about the effects of water-level drawdowns on submerged aquatic plants. In principle, obligately submerged taxa such as Ribbon Weed *Vallisneria* spp. lack well-developed anatomical or physiological mechanisms to withstand desiccation and should die if exposed to the air for long periods (Brock and Casanova 2000). Salter, Morris and Boon (2008) showed that, in some brackish-water wetlands of the Gippsland Lakes in south-eastern Victoria, moderate to severe air drying reduced the biomass of *Vallisneria australis* by up to 95%. This result is consistent with the findings of Rogers (2011), who concluded that Australian *Vallisneria* spp. often had a growth cycle similar to that of annual species, in that if

the time for their canopy to develop fully was too short there was a marked decline in reproductive output and in growth rate once reproduction had ceased. Even so, there are strong evolutionary reasons why even submerged plant taxa should have developed some tolerance to episodic desiccation, and indeed they can often withstand exposure to the air if they remain as thick mats on damp sediments, as shown by the repeated lack of success of attempts to control problematic growth of submerged angiosperms by water-level drawdowns alone.

Little is known of the hydrological requirements for obligately submerged plants to recruit sexually (Roberts and Marston 2000, 2011; Rogers 2011), but Salter et al. (2010) showed that germination of *Vallisneria australis* seed was slowed by drying and significant germination still occurred 20–30 weeks after dried seeds had been re-wetting. The final percentage germination of seeds that had been dried and then rewetted was about twice that of seeds that remained wet. Moreover, sediment-stored seeds germinated only after drying, which suggests that water level drawdowns might promote germination of *Vallisneria australis* in the field. This result is also consistent with the conclusions reached by Rogers (2011), who reported the presence of *Vallisneria* spp. in wetlands that experienced a wide range of wetting and drying regimes, from near-permanent inundation to regular drying.

In summary, near-permanent water is required in wetlands for obligately submerged angiosperms such as *Vallisneria* spp. They can withstand episodic drawdowns of water levels, but there are likely to be strong impacts on biomass accumulation during the following growing season. It is not clear what water regime is required for sexual recruitment, but it is likely that asexual (clonal) spread will be extensive in many species during the wet (inundated) phase, especially over summer when vegetative growth is fastest.

### **3.4 Maintain channel form and promote habitat diversity**

#### **Description**

Channel form describes the size, shape and diversity of the river channel. The physical form of a river can be described at a range of spatial scales, from the catchment to the microhabitat scale (Sear 1996), which can each correlate with habitat types (Frissell et al. 1986). A diversity of habitat types provides the physical basis for a diversity of biota (Treadwell et al. 2006, Newson 2002), and consequently is an important factor in providing a healthy river. Physical features that provide habitat niches include meanders, pools, benches, bars, bank undercuts and variations in substrate. Each of these physical features interacts with flow to create hydraulic habitats (e.g. secondary flow structures at meanders, or areas of slack water on benches) that are preferentially used by different biota (Sagnes, Merigoux and Peru 2008). A diversity of channel form therefore provides a diversity of both physical and hydraulic habitats.

Field observation and inspection of cross-sections from the topographic survey of representative sites shows the predominant physical features in the channels of the Yanco system to be deep pools and benches. The maintenance of the pools and benches is an important geomorphic objective.

#### **Relevant reaches**

This environmental objective applies to all reaches in the Yanco Creek system unaffected by weir pools (i.e. reaches 1, 2, 4a, 5, 6b)

#### **Flow objectives**

The physical form of a stream depends on its flow regime, the characteristics of its bed and bank sediment, the riparian and instream vegetation, valley controls (such as confinement and valley slope), the sediment inflow regime. The geomorphic processes and form change over time if any of the factors, for example changes in the flow regime through regulation (Gregory, Benito & Downs 2008), removal of riparian vegetation (Simon & Collison 2002) and interruptions in the sediment supply from upstream (Petts & Gurnell 2005).

The central management option considered in an environmental flow study is the flow regime. Maintaining the deep pools and benches that provide the diversity of channel form in the Yanco System requires identification and provision of critical flow components within the flow regime.

Pools and benches have been identified as ecologically important physical features by a number of authors (Thoms, Ogden & Reid 1999, Shi, Petts & Gurnell 1999) and have become a central focus of environmental



flow allocation studies in Australia. The role of these features in ecosystem health in the Yanco System is described in other sections.

Bankfull flow is important for formation and maintenance of channel form and diversity (US Department of Agriculture 2007; Knighton 1998). It is commonly used as an analog for the *dominant discharge*, i.e. the single flow that determines channel features such as cross-sectional capacity (Wolman & Leopold 1957) or the flow considered to do most geomorphic work in terms of sediment transport (Wolman & Miller 1960).

Changes in the frequency of bankfull flow are likely to lead to changes in channel form, potentially leading to the removal of physical features important as habitats. Providing bankfull flows is therefore important to maintain the gross channel form (i.e. the general size and shape of the channel) and in particular deep pools. There is some evidence (Vietz et al. 2012) that bankfull flows (or flows close to bankfull) are also important for bench maintenance.

The geomorphic and hydraulic processes leading to the formation and maintenance of benches has been the subject of some research (e.g. Page and Nanson 1992, Vietz et al 2012), and the occurrence of large inchannel events has been identified as important for promoting flow separation and fine-grained sediment deposition.

The flow processes required to meet the environmental objective are:

- Maintenance of gross channel physical form and inchannel features (bankfull flow)
- Bench maintenance flow (1 m depth over benches)
- Sediment mobilisation flow (flow that generates shear stress of  $1.1 \text{ N/m}^2$  to mobile coarse sand that accumulates in pools)

The flow components to achieve these flow processes are bankfull and overbank flows.

### 3.5 Maintain drought refuge habitat

#### Description

During drought periods, large areas of aquatic habitats are placed under stress, due to low or absent flows and poor water quality. Under these conditions, species of plants and animals can become locally extinct, or suffer declines in condition or breeding ability that severely reduce population sizes. While historically, native biota have adapted to surviving periods of drought by developing resistance traits (the ability to survive through low flows and poor water quality) or resilience traits (the ability to rapidly breed and spread following the breaking of the drought).

The desirable ecological condition for refuge habitats have been identified (eWater CRC 2012):

- areas that contain persistent water and are large enough to maintain populations
- areas with water quality that is good enough to support species
- areas with little or no physical disturbance
- areas with access between habitats following the drought

The potential for species to survive droughts depends on the availability of suitable and adequate habitat for biota to live during dry periods. Human intervention has reduced the natural ability of species to survive drought conditions through a number of activities – reductions in flows, sedimentation of habitats, stock access to rivers and clearing of riparian vegetation that reduce the ability to survive during the drought, and the construction of barriers that reduce the ability to recolonise and spread following the drought.

Because of these changes, maintaining refuges during drought periods is essential if species are to continue into the future. Many of the natural drought refuges (deep pools, off-stream wetlands) have been reduced in

size and occurrence across the Murray-Darling landscape. The weir pools present on the Yanco Creek system provide an opportunity to be managed as additional secure drought refuge areas.

### Relevant reaches

Three of the reaches in the Yanco Creek system contain a number of weir pools with essentially no sections of flowing water between them (i.e. the head of one weir pool coincides with the tail of the next weir pool downstream) – Colombo Creek, Billabong Creek between Jerilderie and the confluence with Yanco Creek and the regulated section of Forest Creek from the junction with Billabong Creek and Warriston Weir.

### Flow objectives

Within each weir pool, there are three main habitat areas – fringing vegetation, open water and the sediments at the bottom of the weir – similar to the habitats found in natural drought refuge pools. Each provides a distinct habitat environment for different types of biota (e.g. large-bodied fish in open water and smaller fish amongst fringing vegetation). In a natural drought refuge, as the drought progresses (assuming no flow), the volume of water declines due to evaporation and seepage, and water quality declines as water temperatures increase and dissolved oxygen decreases. Deeper pools may thermally stratify (warm water on the surface and colder water below with little or no mixing), leading to further declines in dissolved oxygen in the lower levels and the potential for algal blooms. As the volume declines, fringing vegetation becomes less inundated, reducing the amount and suitability of habitat.

By manipulating flows into the weir pools during drought periods, it should be possible to maintain the volume of water, and hence habitat availability, and to prevent declines in water quality. This is achieved by providing an inflow that is at least as great as the evaporation rate, and is sufficient to prevent long periods of stagnation and declines in water quality.

Equations to calculate evaporation rates from open waters in the Murray-Darling Basin have been derived by McJannett et al. (2008), but require detailed knowledge and time series of water temperature, wind speed, solar radiation and pressure, which are not available.

Criteria for achieving the flow required to prevent water quality declines during droughts are difficult to determine. The response of individual weir pools to periods of very low inflows is likely to be quite specific to each pool, determined by factors such as surface area, depth and aspect (due to the mixing effect of wind), and reported flows required to prevent stratification or algal blooms are quite variable.

In the lower Darling River, Mitrovic et al. (2003, 2011) found that discharges which resulted in a flow velocity of 0.03 – 0.05 m/sec were sufficient to prevent prolonged periods of persistent thermal stratification, which also suppressed the development of the cyanobacteria *A. circinalis* blooms. Two papers by Webster et al. (1997, 2000) showed that cyanobacterial blooms occurred in Maude Weir pool (just downstream of Hay on the Murrumbidgee) when flows were <500 ML/day, and that blooms did not occur at flows of >1,000 ML/day. Webster et al. didn't give a volume for the weir pool, however it is estimated to be ~5,000 ML. This means that cyanobacterial blooms did not occur at the Maude Weir pool if the turn-over time was ~5 days, but developed if the turn-over time exceeded ~9-10 days. Although cyanobacteria were encouraged by long turn-over times of 9-10 days, shorter turn-over times instead encouraged the diatom *Melosira*. Short turn-over times (i.e. larger incoming flows) created rapid mixing of the water-column from top to bottom of the weir pool, and this allowed the relatively heavy diatoms to stay suspended in the water column rather than sinking to the bottom and falling out of the photic zone.

At Maude Weir pool with short turn-over times (e.g. <5-7 days) cyanobacteria are selected against, as the water column remains well mixed (i.e. does not thermally stratify) and algal cells are mixed down into the deeper layers which, in turbid waters, are too dim for rapid growth. Under these well-mixed conditions, heavy cells that cannot control their buoyancy, such as the very common diatom *Melosira*, are selected for as they are kept high in the water-column by the turbulent flow. Conversely, long turn-over times (>10 days) allow the water-column to stratify strongly; under these conditions, diatoms sink and cyanobacteria (e.g. *Anabaena*) are selected for.

Oliver et al. (1999) worked on weir pools along the Darling. In Bourke Weir pool, cyanobacterial blooms developed when flows were <800 ML/day. The weir pool has a volume of 4,500 ML, so this corresponds to a

turn-over time of ~6 days. Moderate cyanobacterial populations developed at flows of 500 ML/day (= turn-over time of 9 days). Both figures are reassuring similar to the ~5-7 days and ~9-10 days estimated from the data of Webster et al.

It is important to note that the development of a cyanobacterial bloom is dependent not only on flow, but also on the initial abundance of cells that initiate the bloom. If, for example, the initial cell number is low, it can take 9-26 days for problematic blooms to develop in Bourke Weir pool. In other words, whether a cyanobacterial bloom develops is not controlled only by flushing rate, but also by the size of the inoculum and the water temperature. This may not be an important consideration for Yanco Creek system, but it does show that long turn-over times will not automatically generate a cyanobacterial bloom.

It is therefore recommended to provide flow rates for both a 7-day and a 14-day estimated turn-over time for the weir pools. The shorter rate (a weekly turn-over) is more likely to prevent cyanobacterial blooms, but will require more water and could encourage a diatom bloom. The longer rate (once every 14 days) is more likely to result in a cyanobacterial bloom, but will use less water and is likely to discourage *Melosira*.

### **3.6 Support self sustaining populations of macroinvertebrate taxa from the endangered Lower Murray Aquatic Ecological Community and those found in mid-Murrumbidgee wetlands**

#### **Description**

Because of the paucity of data on the diversity and composition of macroinvertebrates in the Yanco Creek system, there are no specific objectives for macroinvertebrate communities in the system. However, Yanco Creek lies in the area covered by the “Lower Murray Aquatic Ecological Community” so that flows can be used to help promote the survival and sustainability of that community. In addition, the upper reaches of the system lie in the area covered by the Murrumbidgee Catchment Management Plan (MCMA 2008) and opportunities exist to support the objectives of the plan to “protect and enhance the terrestrial and aquatic biodiversity of the Murrumbidgee catchment in order to restore balance to the terrestrial and aquatic ecosystems” (p. 46).

#### **Relevant reaches**

All reaches in the Yanco Creek system lie in the area covered by the “Lower Murray Aquatic Ecological Community”, while only Reach 1 and parts of Reaches 2 and 3 lie in the Murrumbidgee Catchment management Authority region.

#### **Flow objectives**

Maintaining or improving the macroinvertebrate community requires the maintenance of a suitable baseflow in reaches at all times. The baseflow should be sufficient to inundate the major habitats for macroinvertebrate production (primarily the stream bed, at least parts of woody debris and the fringing vegetation and exposed tree roots). A variable low flow regime that sequentially inundates and exposes parts of the woody debris can increase the productivity of algal biofilms, and hence the amount of available food (Ryder 2004).

Additional to adequate low flows, short periods of higher flows (freshes) are required to prevent the build up of fine sediment on structural habitat at times of year when flows are low. Higher scouring flows are required to disturb the algae/bacteria/organic biofilm present on woody debris (a major food source for macroinvertebrates). This disturbance is believed to maintain a diversity of available food sources.

In wetlands, providing a mosaic of different wetting and drying cycles (from permanent to ephemeral) would support the wide range of macroinvertebrate that would be found in Murrumbidgee wetlands.

### **3.7 Maintain and improve large and medium-bodied native fish community**

#### **Description**

Medium and large-bodied fish populations have declined in many areas of the Murray-Darling Basin and this has often been associated with river regulation and habitat removal. Several large-bodied fish are nationally

threatened and remain in areas where there is permanent flow and good instream habitat, such as the Murrumbidgee River and Yanco Creek system (such as Murray Cod and Trout Cod). Delivery of appropriate flows to stimulate movement, spawning and recruitment is important to maintain the health of existing populations and also to stimulate recruitment and improve the abundance of exiting fish and maximise their distribution.

Characteristics of the life history for large-bodied fish (Murray Cod, Trout Cod, Freshwater Catfish) are:

- Cod can live for 40+ years and mature at 3-4 years for males and 4-5 years for females.
- Adults are often associated with 'home snags' but move from mid-August to mid December.
- Adult fish have moderate numbers of eggs and spawn between early October and early December.
- Stable or rising flows are associated with spawning.
- Female fish may partner one or more males and males guard the nest.
- Larvae remain at the nest for 5-13 days and then may drift downstream for up to 7 days.
- Juvenile fish settle and are often associated with snags or instream cover.

Characteristics of the life history for medium bodied fish (Golden Perch, Silver Perch, Bony Herring) include:

- Fish can live for 25+ years and mature at 2-3 years for males and 3-4 years for females
- Adult fish develop large numbers of eggs over winter and early spring and spawn from October-January.
- Increasing temperature and river flow triggers fish to spawn.
- Eggs and larvae are pelagic and can drift downstream for up to 2 weeks
- Juveniles settle and then disperse with upstream migration by 1+ year old fish

### **Relevant reaches**

Large and medium bodied fish are expected to be present in all reaches of the Yanco Creek system except for Forest Creek (Reach 6). Fish surveys are recommended to confirm the actual distribution of species in each reach to refine the applicability of this environmental objective to reaches over time.

### **Flow objectives**

Important flow processes to achieve the environmental objective are:

- Stimulate key life-history processes (e.g. egg production, movement, spawning, recruitment)
- Maximise habitat availability, snags, littoral margins, wetlands, major offstream water bodies (e.g. Dry Lake and Mollys Lagoon)
- Enhance juvenile dispersal and colonisation of newly available habitats and maximise fish distributions
- Enable threatened fishes (i.e. Murray Cod, Trout Cod, Freshwater Catfish) to complete life-history and build resilience among these populations

The ability of fish to move to preferred habitats for feeding, spawning and recruitment is achieved with an appropriate environmental flow. Key life-history processes (e.g. movement to spawning areas) are initiated by appropriately timed flow events. The flow objectives are directly linked to fish outcomes with some fish being stimulated to complete their spawning by rising flows.

Large and medium bodied fish have reasonably predictable ecological responses to environmental water delivery. Rising spring flows will initiate movement and potentially spawning and flows should also aim to

maximise the time for fish to find a mate, spawn and in the case of Murray Cod enhance access to suitable spawning sites. Daily variation (e.g. +/-150 mm of bank height) also help to stimulate important ecological processes such as migration.

The aims of the environmental flow are to:

- promote movement of large/medium-bodied fish on the ascending limb of a flow rise
- increase habitat availability including snags and undercuts where fish select nest sites and spawn
- promote successful spawning, egg survival and larval dispersal.

The shape of the hydrograph (Figure 13) is provided as a guide only, the timing and minimum duration (see table) of the flows are more important than whether there is one or several peaks.

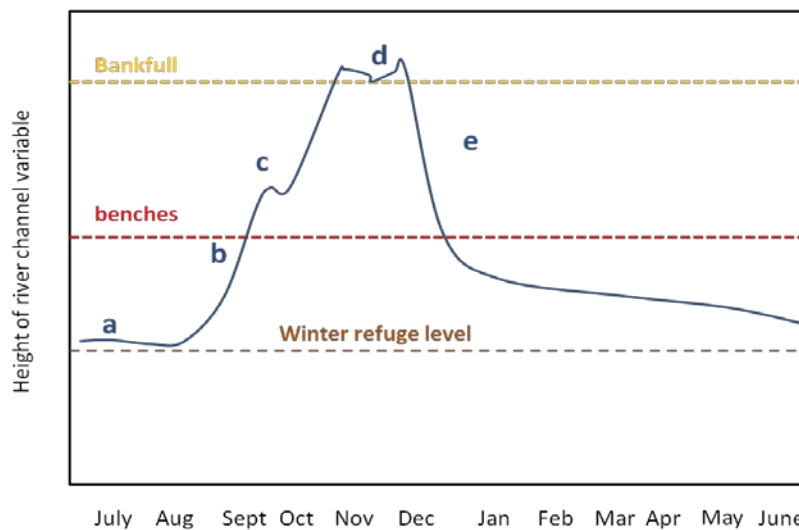

Key	Flow component	Timing	Duration	Fish rationale
a	Winter connection	Jan-July	Continuous	Connect pools
b	Ramp up	Mid August	5-7 days	Stimulate movement
c	Inundate benches	September-October	21 days	Inundate spawning areas
d	Peak	November	7-12 days	Spawning, hatching and larval dispersal
e	Ramp down	Mid December	5-12 days	Restore connecting flows

**Figure 13.** Conceptual hydrograph for large and medium bodied fish species

### 3.8 Maintain small-bodied generalist native fish community

#### Description

Small-bodied fish populations have declined in some areas of the Murray-Darling Basin but in many areas, such as Yanco Creek, there are still strong and healthy populations of these fish. Small fish are important indicators of functioning systems and these play an important role in a healthy and diverse fish community. Delivery of appropriate flows to enhance, spawning and recruitment is of moderate importance to generalist species. Flows stimulate primary production and can benefit the maintenance of small-bodied fish communities.

Characteristics of these small-bodied generalist native fish (mainly Carp Gudgeons, Flat-Headed Gudgeons, Australian Smelt, Unspecked Hardyhead and Murray Rainbowfish) include:

- probable life-span is 1-3 years
- adult fish can spawn at low flows and rising flows in the main river or off-channel
- larvae can recruit in off-channel habitats and fish move between the main channel and lagoons

#### Relevant reaches

Small bodied generalist fish are expected to be present in every reach of the Yanco Creek system.

#### Flow objectives

Important flow processes to achieve the environmental objective are:

- stimulate key life-history processes (e.g. egg production, movement to littoral habitats, spawning, recruitment)
- maximise habitat availability, littoral margins, wetlands, major off stream lakes
- enhance juvenile dispersal and colonisation of newly available habitats and maximise fish distributions
- enable threatened fishes(Flat-headed Galaxias) to complete life-history and build resilience among these populations

The ability of fish to move to preferred habitats for feeding, spawning and recruitment is achieved with an appropriate environmental flow. Key life-history processes (e.g. movement to littoral spawning areas and low lying wetlands) are initiated by appropriately timed flow events. The flow objectives are directly linked to fish outcomes with some fish having maximised recruitment with access to shallow littoral areas and backwaters.

Small-bodied fish are active in spring and summer, migrating, spawning and recruiting during low and rising flows. Often these fish spawn and inhabit shallow littoral margins and stream benches and will also move into low lying wetlands. Environmental flows for small-bodied fish can achieve their objectives (spawning and recruitment) with frequent smaller flow peaks that increase access to shallow marginal habitat.

The aims of the environmental flow are:

- Promote opportunities for small-bodied fish to access shallow littoral habitat or low lying wetlands.
- Inundate stream benches, woody debris and riparian vegetation.
- Promote successful spawning, egg survival and larval dispersal over spring and summer.

The shape of the hydrograph (Figure 14) is provided as a guide only, the timing and minimum duration (see table) of the flows are more important than whether there is one or several peaks. Three or four pulsed flows over spring and summer are required with 2-3 weeks between pulses.